



User's Manual

Micrium
For the Way Engineers Work

Micrium
1290 Weston Road, Suite 306
Weston, FL 33326
USA

www.micrium.com

Designations used by companies to distinguish their products are often claimed as trademarks. In all instances where Micrium Press is aware of a trademark claim, the product name appears in initial capital letters, in all capital letters, or in accordance with the vendor's capitalization preference. Readers should contact the appropriate companies for more complete information on trademarks and trademark registrations. All trademarks and registered trademarks in this book are the property of their respective holders.

Copyright © 2012 by Micrium except where noted otherwise. All rights reserved. Printed in the United States of America. No part of this publication may be reproduced or distributed in any form or by any means, or stored in a database or retrieval system, without the prior written permission of the publisher; with the exception that the program listings may be entered, stored, and executed in a computer system, but they may not be reproduced for publication.

The programs and code examples in this book are presented for instructional value. The programs and examples have been carefully tested, but are not guaranteed to any particular purpose. The publisher does not offer any warranties and does not guarantee the accuracy, adequacy, or completeness of any information herein and is not responsible for any errors or omissions. The publisher assumes no liability for damages resulting from the use of the information in this book or for any infringement of the intellectual property rights of third parties that would result from the use of this information.

Table of Contents

Chapter 1	Introduction	15
1-1	μC/FS	15
1-2	Typical Usages	17
1-3	Why FAT?	17
1-4	Chapter Contents	18
Chapter 2	μC/FS Architecture	23
2-1	Architecture Components	25
2-1-1	Your Application	25
2-1-2	μC-LIB (Libraries)	25
2-1-3	POSIX API Layer	25
2-1-4	FS Layer	26
2-1-5	File System Driver Layer	27
2-1-6	Device Driver Layer	27
2-1-7	μC-CPU	28
2-1-8	RTOS Layer	28
Chapter 3	μC/FS Directories and Files	29
3-1	Application Code	32
3-2	CPU	34
3-3	Board Support Package (BSP)	35
3-4	μC/CPU, CPU Specific Source Code	36
3-5	μC/LIB, Portable Library Functions	38
3-6	μC/Clk, Time/Calendar Management	39
3-7	μC/CRC, Checksums and Error Correction Codes	41
3-8	μC/FS Platform-Independent Source Code	42
3-9	μC/FS FAT Filesystem Source Code	45
3-10	μC/FS Memory Device Drivers	46
3-11	μC/FS Platform-Specific Source Code	50

3-12	μC/FS OS Abstraction Layer	51
3-13	Summary	52
Chapter 4	Useful Information	59
4-1	Nomenclature	59
4-2	μC/FS Device and Volume Names	61
4-3	μC/FS File and Directory Names and Paths	62
4-4	μC/FS Name Lengths	64
4-5	Resource Usage	65
Chapter 5	Devices and Volumes	67
5-1	Device Operations	68
5-2	Using Devices	69
5-3	Using Removable Devices	71
5-4	Raw Device IO	72
5-5	Partitions	73
5-6	Volume Operations	76
5-7	Using Volumes	77
5-8	Using Volume Cache	79
5-8-1	Choosing Cache Parameters	81
5-8-2	Other Caching and Buffering Mechanisms	82
Chapter 6	Files	83
6-1	File Access Functions	84
6-1-1	Opening Files	85
6-1-2	Getting Information About a File	86
6-1-3	Configuring a File Buffer	87
6-1-4	File Error Functions	88
6-1-5	Atomic File Operations Using File Lock	88
6-2	Entry Access Functions	89
6-2-1	File and Directory Attributes	90
6-2-2	Creating New Files and Directories	91
6-2-3	Deleting Files and Directories	92
Chapter 7	Directories	93
7-1	Directory Access Functions	94

Chapter 8	POSIX API	95
8-1	Supported Functions	96
8-2	Working Directory Functions	97
8-3	File Access Functions	98
8-3-1	Opening, Reading and Writing Files	100
8-3-2	Getting or Setting the File Position	103
8-3-3	Configuring a File Buffer	104
8-3-4	Diagnosing a File Error	106
8-3-5	Atomic File Operations Using File Lock	106
8-4	Directory Access Functions	107
8-5	Entry Access Functions	109
Chapter 9	Device Drivers	111
9-1	Provided Device Drivers	112
9-1-1	Driver Characterization	113
9-2	Drivers comparison	115
Chapter 10	FAT File System	117
10-1	Why Embedded Systems Use FAT	117
10-2	Organization of a FAT Volume	118
10-2-1	Organization of Directories and Directory Entries	119
10-3	Organization of the File Allocation Table	120
10-3-1	FAT12 / FAT16 / FAT32	122
10-3-2	Short and Long File Names	123
10-4	Formatting	126
10-5	Sources of Corruption in FAT Volumes	127
10-6	Optional Journaling System	127
10-7	Licensing Issues	129
10-7-1	Licenses for Long File Names (LFNs)	129
10-7-2	Extended File Allocation Table (exFAT)	129
Chapter 11	RAM Disk Driver	131
11-1	Files and Directories	131
11-2	Using the RAM Disk Driver	132

Chapter 12	SD/MMC Drivers	135
12-1	Files and Directories	137
12-2	Using the SD/MMC CardMode Driver	138
12-2-1	SD/MMC CardMode Communication	141
12-2-2	SD/MMC CardMode Communication Debugging	144
12-2-3	SD/MMC CardMode BSP Overview	148
12-3	Using the SD/MMC SPI Driver	150
12-3-1	SD/MMC SPI Communication	153
12-3-2	SD/MMC SPI Communication Debugging	154
12-3-3	SD/MMC SPI BSP Overview	157
Chapter 13	NAND Flash Driver	159
13-1	Getting Started	160
13-2	Architecture Overview	167
13-3	NAND Translation Layer	168
13-3-1	Translation Layer Configuration	171
13-3-2	Translation Layer Source Files	178
13-4	Controller Layer	178
13-4-1	Generic Controller Layer Implementation	179
13-4-2	Part Layer	181
13-5	Board Support Package - Generic Controller	185
13-6	Board Support Package - Other Controllers	186
13-7	Performance Considerations	187
13-8	Development Guide	188
13-8-1	BSP Development Guide - Generic Controller	189
13-8-2	Generic Controller Extension Development Guide	191
13-8-3	ECC Module Development Guide	193
13-8-4	Controller Layer Development Guide	194
Chapter 14	NOR Flash Driver	199
14-1	Files and Directories	200
14-2	Driver and Device Characteristics	202
14-3	Using a Parallel NOR Device	204
14-3-1	Driver Architecture	208
14-3-2	Hardware	208
14-3-3	NOR BSP Overview	210

14-4	Using a Serial NOR Device	211
14-4-1	Hardware	212
14-4-2	NOR SPI BSP Overview	213
14-5	Physical-Layer Drivers	214
14-5-1	FSDev_NOR_AMD_1x08, FSDev_NOR_AMD_1x16	215
14-5-2	FSDev_NOR_Intel_1x16	215
14-5-3	FSDev_NOR_SST39	216
14-5-4	FSDev_NOR_STM25	216
14-5-5	FSDev_NOR_SST25	217
Chapter 15	MSC Driver	219
15-1	Files and Directories	219
15-2	Using the MSC Driver	220
Appendix A	μ C/FS API Reference	223
A-1	General File System Functions	225
A-1-1	FS_DevDrvAdd()	226
A-1-2	FS_Init()	227
A-1-3	FS_VersionGet()	228
A-1-4	FS_WorkingDirGet()	229
A-1-5	FS_WorkingDirSet()	230
A-2	Posix API Functions	231
A-2-1	fs_asctime_r()	234
A-2-2	fs_chdir()	235
A-2-3	fs_clearerr()	236
A-2-4	fs_closedir()	237
A-2-5	fs_ctime_r()	238
A-2-6	fs_fclose()	239
A-2-7	fs_feof()	240
A-2-8	fs_ferror()	241
A-2-9	fs_fflush()	242
A-2-10	fs_fgetpos()	243
A-2-11	fs_flockfile()	244
A-2-12	fs_fopen()	245
A-2-13	fs_fread()	246
A-2-14	fs_fseek()	247
A-2-15	fs_fsetpos()	249

A-2-16	<code>fs_ftell()</code>	250
A-2-17	<code>fs_ftruncate()</code>	251
A-2-18	<code>fs_ftrylockfile()</code>	252
A-2-19	<code>fs_funlockfile()</code>	253
A-2-20	<code>fs_fwrite()</code>	254
A-2-21	<code>fs_getcwd()</code>	255
A-2-22	<code>fs_localtime_r()</code>	256
A-2-23	<code>fs_mkdir()</code>	257
A-2-24	<code>fs_mktime()</code>	258
A-2-25	<code>fs_opendir()</code>	259
A-2-26	<code>fs_readdir_r()</code>	260
A-2-27	<code>fs_remove()</code>	261
A-2-28	<code>fs_rename()</code>	263
A-2-29	<code>fs_rewind()</code>	265
A-2-30	<code>fs_rmdir()</code>	266
A-2-31	<code>fs_setbuf()</code>	267
A-2-32	<code>fs_setvbuf()</code>	268
A-3	Device Functions	270
A-3-1	<code>FSDev_AccessLock()</code>	273
A-3-2	<code>FSDev_AccessUnlock()</code>	274
A-3-3	<code>FSDev_Close()</code>	275
A-3-4	<code>FSDev_GetDevName()</code>	276
A-3-5	<code>FSDev_GetDevCnt()</code>	277
A-3-6	<code>FSDev_GetDevCntMax()</code>	278
A-3-7	<code>FSDev_GetNbrPartitions()</code>	279
A-3-8	<code>FSDev_Invalidate()</code>	280
A-3-9	<code>FSDev_Open()</code>	281
A-3-10	<code>FSDev_PartitionAdd()</code>	283
A-3-11	<code>FSDev_PartitionFind()</code>	284
A-3-12	<code>FSDev_PartitionInit()</code>	286
A-3-13	<code>FSDev_Query()</code>	287
A-3-14	<code>FSDev_Rd()</code>	288
A-3-15	<code>FSDev_Refresh()</code>	289
A-3-16	<code>FSDev_Wr()</code>	291
A-4	Directory Access Functions	292
A-4-1	<code>FSDir_Close()</code>	293
A-4-2	<code>FSDir_IsOpen()</code>	294
A-4-3	<code>FSDir_Open()</code>	295

A-4-4	FSDir_Rd()	296
A-5	Entry Access Functions	297
A-5-1	FSEntry_AttribSet()	298
A-5-2	FSEntry_Copy()	300
A-5-3	FSEntry_Create()	302
A-5-4	FSEntry_Del()	304
A-5-5	FSEntry_Query()	306
A-5-6	FSEntry_Rename()	307
A-5-7	FSEntry_TimeSet()	309
A-6	File Functions	311
A-6-1	FSFile_BufAssign()	313
A-6-2	FSFile_BufFlush()	315
A-6-3	FSFile_Close()	316
A-6-4	FSFile_ClrErr()	317
A-6-5	FSFile_IsEOF()	318
A-6-6	FSFile_IsErr()	319
A-6-7	FSFile_IsOpen()	320
A-6-8	FSFile_LockAccept()	321
A-6-9	FSFile_LockGet()	322
A-6-10	FSFile_LockSet()	323
A-6-11	FSFile_Open()	324
A-6-12	FSFile_PosGet()	326
A-6-13	FSFile_PosSet()	327
A-6-14	FSFile_Query()	329
A-6-15	FSFile_Rd()	330
A-6-16	FSFile_Truncate()	332
A-6-17	FSFile_Wr()	333
A-7	Volume Functions	335
A-7-1	FSVol_Close()	337
A-7-2	FSVol_Fmt()	338
A-7-3	FSVol_GetDfltVolName()	340
A-7-4	FSVol_GetVolCnt()	341
A-7-5	FSVol_GetVolCntMax()	342
A-7-6	FSVol_GetVolName()	343
A-7-7	FSVol_IsDflt()	344
A-7-8	FSVol_IsMounted()	345
A-7-9	FSVol_LabelGet()	346
A-7-10	FSVol_LabelSet()	348

A-7-11	FSVol_Open()	350
A-7-12	FSVol_Query()	352
A-7-13	FSVol_Rd()	353
A-7-14	FSVol_Wr()	355
A-8	Volume Cache Functions	356
A-8-1	FSVol_CacheAssign()	357
A-8-2	FSVol_CacheInvalidate ()	359
A-8-3	FSVol_CacheFlush ()	360
A-9	SD/MMC Driver Functions	361
A-9-1	FSDev_SD_xxx_QuerySD()	362
A-9-2	FSDev_SD_xxx_RdCID()	364
A-9-3	FSDev_SD_xxx_RdCSD()	366
A-10	NAND Driver Functions	368
A-10-1	FSDev_NAND_LowFmt()	369
A-10-2	FSDev_NAND_LowMount()	370
A-10-3	FSDev_NAND_LowUnmount()	372
A-11	NOR Driver Functions	373
A-11-1	FSDev_NOR_LowFmt()	374
A-11-2	FSDev_NOR_LowMount()	375
A-11-3	FSDev_NOR_LowUnmount()	376
A-11-4	FSDev_NOR_LowCompact()	377
A-11-5	FSDev_NOR_LowDefrag()	378
A-11-6	FSDev_NOR_PhyRd()	379
A-11-7	FSDev_NOR_PhyWr()	381
A-11-8	FSDev_NOR_PhyEraseBlk()	383
A-11-9	FSDev_NOR_PhyEraseChip()	385
A-12	FAT System Driver Functions	386
A-12-1	FS_FAT_JournalOpen()	387
A-12-2	FS_FAT_JournalClose()	388
A-12-3	FS_FAT_JournalStart()	389
A-12-4	FS_FAT_JournalStop()	390
A-12-5	FS_FAT_VolChk()	391
Appendix B	µC/FS Error Codes	393
B-1	System Error Codes	393
B-2	Buffer Error Codes	393
B-3	Cache Error Codes	394
B-4	Device Error Codes	394

B-5	Device Driver Error Codes	395
B-6	Directory Error Codes	395
B-7	ECC Error Codes	395
B-8	Entry Error Codes	395
B-9	File Error Codes	396
B-10	Name Error Codes	397
B-11	Partition Error Codes	397
B-12	Pools Error Codes	397
B-13	File System Error Codes	398
B-14	Volume Error Codes	398
B-15	OS Layer Error Codes	399
Appendix C	µC/FS Porting Manual	401
C-1	Date/Time Management	403
C-2	CPU Port	403
C-3	OS Kernel	404
C-4	Device Driver	412
C-4-1	NameGet()	414
C-4-2	Init()	415
C-4-3	Open()	416
C-4-4	Close()	418
C-4-5	Rd()	419
C-4-6	Wr()	421
C-4-7	Query()	423
C-4-8	IO_Ctrl()	424
C-5	SD/MMC Cardmode BSP	425
C-5-1	FSDev_SD_Card_BSP_Open()	429
C-5-2	FSDev_SD_Card_BSP_Lock/Unlock()	430
C-5-3	FSDev_SD_Card_BSP_CmdStart()	431
C-5-4	FSDev_SD_Card_BSP_CmdWaitEnd()	436
C-5-5	FSDev_SD_Card_BSP_CmdDataRd()	440
C-5-6	FSDev_SD_Card_BSP_CmdDataWr()	443
C-5-7	FSDev_SD_Card_BSP_GetBlkCntMax()	446
C-5-8	FSDev_SD_Card_BSP_GetBusWidthMax()	447
C-5-9	FSDev_SD_Card_BSP_SetBusWidth()	448
C-5-10	FSDev_SD_Card_BSP_SetClkFreq()	450
C-5-11	FSDev_SD_Card_BSP_SetTimeoutData()	451
C-5-12	FSDev_SD_Card_BSP_SetTimeoutResp()	452

C-6	SD/MMC SPI mode BSP	452
C-7	SPI BSP	453
C-7-1	Open()	457
C-7-2	Close()	459
C-7-3	Lock() / Unlock()	460
C-7-4	Rd()	461
C-7-5	Wr()	462
C-7-6	ChipSelEn() /ChipSelDis()	463
C-7-7	SetClkFreq()	464
C-8	NAND Flash Physical-Layer Driver	464
C-9	NOR Flash Physical-Layer Driver	464
C-9-1	Open()	467
C-9-2	Close()	468
C-9-3	Rd()	469
C-9-4	Wr()	470
C-9-5	EraseBlk()	471
C-9-6	IO_Ctrl()	472
C-10	NOR Flash BSP	473
C-10-1	FSDev_NOR_BSP_Open()	474
C-10-2	FSDev_NOR_BSP_Close()	475
C-10-3	FSDev_NOR_BSP_Rd_XX()	476
C-10-4	FSDev_NOR_BSP_RdWord_XX()	477
C-10-5	FSDev_NOR_BSP_WrWord_XX()	478
C-10-6	FSDev_NOR_BSP_WaitWhileBusy()	479
C-11	NOR Flash SPI BSP	480
Appendix D	μC/FS Types and Structures	481
D-1	FS_CFG	482
D-2	FS_DEV_INFO	484
D-3	FS_DEV_NOR_CFG	485
D-4	FS_DEV_RAM_CFG	488
D-5	FS_DIR_ENTRY (struct fs_dirent)	489
D-6	FS_ENTRY_INFO	490
D-7	FS_FAT_SYS_CFG	492
D-8	FS_PARTITION_ENTRY	494
D-9	FS_VOL_INFO	495

Appendix E	µC/FS Configuration	497
E-1	File System Configuration	498
E-2	Feature Inclusion Configuration	500
E-3	Name Restriction Configuration	503
E-4	Debug Configuration	504
E-5	Argument Checking Configuration	504
E-6	File System Counter Configuration	505
E-7	FAT Configuration	505
E-8	SD/MMC SPI Configuration	506
E-9	Trace Configuration	507
Appendix F	Shell Commands	509
F-1	Files and Directories	510
F-2	Using the Shell Commands	511
F-3	Commands	514
F-3-1	fs_cat	515
F-3-2	fs_cd	516
F-3-3	fs_cp	518
F-3-4	fs_date	519
F-3-5	fs_df	520
F-3-6	fs_ls	521
F-3-7	fs_mkdir	522
F-3-8	fs_mkfs	523
F-3-9	fs_mount	524
F-3-10	fs_mv	525
F-3-11	fs_od	526
F-3-12	fs_pwd	527
F-3-13	fs_rm	528
F-3-14	fs_rmdir	529
F-3-15	fs_touch	530
F-3-16	fs_umount	531
F-3-17	fs_wc	532
F-4	Configuration	533

Table of Contents

Appendix G	Bibliography	535
Appendix H	μ C/FS Licensing Policy	537
H-1	μ C/FS Licensing	537
H-1-1	μ C/FS Source Code	537
H-1-2	μ C/FS Maintenance Renewal	538
H-1-3	μ C/FS Source Code Updates	538
H-1-4	μ C/FS Support	538

Introduction

Files and directories are common abstractions, which we encounter daily when sending an e-mail attachment, downloading a new application or archiving old information. Those same abstractions may be leveraged in an embedded system for similar tasks or for unique ones. A device may serve web pages, play or record media (images, video or music) or log data. The file system software which performs such actions must meet the general expectations of an embedded environment—a limited code footprint, for instance—while still delivering good performance.

1-1 μ C/FS

μ C/FS is a compact, reliable, high-performance file system. It offers full-featured file and directory access with flexible device and volume management including support for partitions.

Source Code: μ C/FS is provided in ANSI-C source to licensees. The source code is written to an exacting coding standard that emphasizes cleanness and readability. Moreover, extensive comments pepper the code to elucidate its logic and describe global variables and functions. Where appropriate, the code directly references standards and supporting documents.

Device Drivers: Device drivers are available for most common media including SD/MMC cards, NAND flash, NOR flash. Each of these is written with a clear, layered structure so that it can easily be ported to your hardware. The device driver structure is simple—basically just initialization, read and write functions—so that μ C/FS can easily be ported to a new medium.

Devices and Volumes: Multiple media can be accessed simultaneously, including multiple instances of the same type of medium (since all drivers are re-entrant). DOS partitions are supported, so more than one volume can be located on a device. In addition, the logical device driver allows a single volume to span several (typically identical) devices, such as a bank of flash chips.

FAT: All standard FAT variants and features are supported including FAT12/FAT16/FAT32 and long file names, which encompasses Unicode file names. Files can be up to 4-GB and volumes up to 8-TB (the standard maximum). An optional journaling module provides total power fail-safety to the FAT system driver.

Application Programming Interface (API): μ C/FS provides two APIs for file and directory access. A proprietary API with parallel argument placement and meaningful return error codes is provided, with functions like `FSFile_Wr()`, `FSFile_Rd()` and `FSFile_PosSet()`. Alternatively, a standard POSIX-compatible API is provided, including functions like `fs_fwrite()`, `fs_fread()` and `fs_fsetpos()` that have the same arguments and return values as the POSIX functions `fwrite()`, `fread()` and `fsetpos()`.

Scalable: The memory footprint of μ C/FS can be adjusted at compile-time based on the features you need and the desired level of run-time argument checking. For applications with limited RAM, features such as cache and read/write buffering can be disabled; for applications with sufficient RAM, these features can be enabled in order to gain better performance.

Portable: μ C/FS was designed for resource-constrained embedded applications. Although μ C/FS can work on 8- and 16-bit processors, it will work best with 32- or 64-bit CPUs.

RTOS: μ C/FS does not assume the presence of a RTOS kernel. However, if you are using a RTOS, a simple port layer is required (consisting of a few semaphores), in order to prevent simultaneous access to core structures from different tasks. If you are not using a RTOS, this port layer may consist of empty functions.

1-2 TYPICAL USAGES

Applications have sundry reasons for non-volatile storage. A subset require (or benefit from) organizing data into named files within a directory hierarchy on a volume—basically, from having a file system. Perhaps the most obvious expose the structure of information to the user, like products that store images, video or music that are transferred to or from a PC. A web interface poses a similar opportunity, since the URLs of pages and images fetched by the remote browser would resolve neatly to locations on a volume.

Another typical use is data logging. A primary purpose of a device may be to collect data from its environment for later retrieval. If the information must persist across device reset events or will exceed the capacity of its RAM, some non-volatile memory is necessary. The benefit of a file system is the ability to organize that information logically, with a fitting directory structure, through a familiar API.

A file system can also store programs. In a simple embedded CPU, the program is stored at a fixed location in a non-volatile memory (usually flash). If an application must support firmware updates, a file system may be a more convenient place, since the software handles the details of storing the program. The boot-loader, of course, would need to be able to load the application, but since that requires only read-only access, no imposing program is required. The ROM boot-loaders in some CPUs can check the root directory of a SD card for a binary in addition to the more usual locations such as external NAND or NOR flash.

1-3 WHY FAT?

File Allocation Table (FAT) is a simple file system, widely supported across major OSs. While it has been supplanted as the format of hard drives in Windows PCs, removable media still use FAT because of its wide support. That is suitable for embedded systems, which would often be challenged to muster the resources for the modern file systems developed principally for large fixed disks.

μ C/FS supports FAT because of the interoperability requirements of removable media, allowing that a storage medium be removed from an embedded device and connected to a PC. All variants and extensions are supported to specification.

A notorious weakness of FAT (exacerbated by early Windows system drivers) is its non-fail safe architecture. Certain operations leave the file system in an inconsistent state, albeit briefly, which may corrupt the disk or force a disk check upon unexpected power failure. μ C/FS minimizes the problem by ordering modifications wisely. The problem is completely solved in an optional journaling module which logs information about pending changes so those can be resumed on start-up after a power failure.

1-4 CHAPTER CONTENTS

Figure 1-1 shows the layout and flow of the book. This diagram should be useful to understand the relationship between chapters. The first (leftmost) column lists chapters that should be read in order to understand μ C/FS's structure. The chapters in the second column give greater detail about the application of μ C/FS. Each of the chapters in the third column examines a storage technology and its device driver. Finally, the fourth column lists the appendices, the topmost being the μ C/FS reference, configuration and porting manuals. Reference these sections regularly when designing a product using μ C/FS.

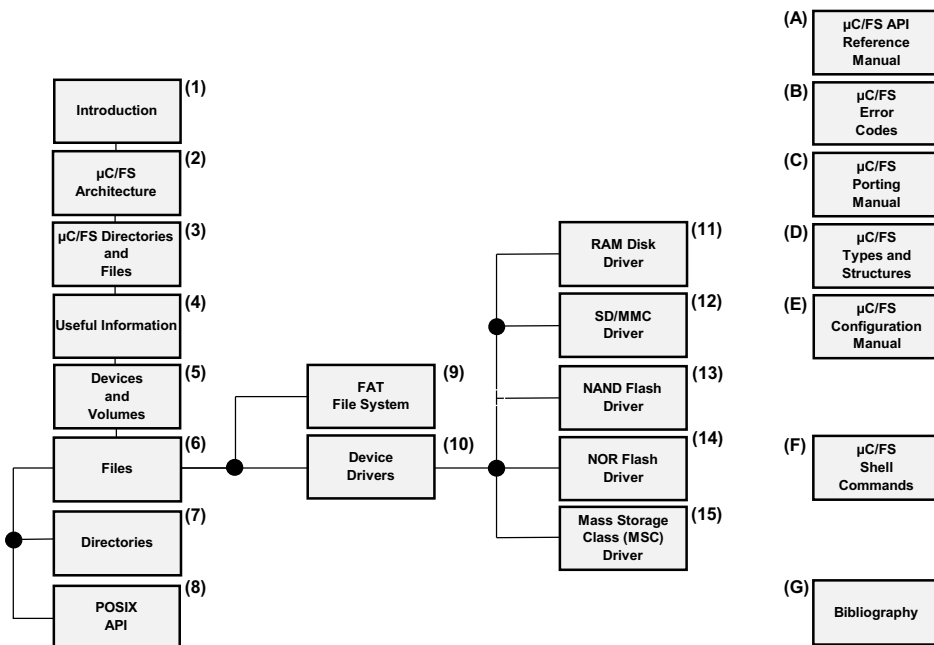

Figure 1-1 μ C/FS book layout

Chapter 1, “Introduction”. This chapter.

Chapter 2, “ μ C/FS Architecture”. This chapter contains a simplified block diagram of the various different μ C/FS modules and their relationships. The relationships are then explained.

Chapter 3, “ μ C/FS Directories and Files”. This chapter explains the directory structure and files needed to build a μ C/FS-based application. Learn about the files that are needed, where they should be placed, which module does what, and more.

Chapter 4, “Useful Information”. In this chapter, you will learn the nomenclature used in μ C/FS to access files and folders and the resources needed to use μ C/FS in your application.

Chapter 5, “Devices and Volumes”. Every file and directory accessed with μ C/FS is a constituent of a volume (a collection of files and directories) on a device (a physical or logical sector-addressed entity). This chapter explains how devices and volumes are managed.

Chapter 6, “Files”. μ C/FS complements the POSIX API with its own file access API. This chapter explains this API.

Chapter 7, “Directories”. μ C/FS complements the POSIX API with its own directory access API. This chapter explains this API.

Chapter 8, “POSIX API”. The best-known API for accessing and managing files and directories is specified within the POSIX standard (IEEE Std 1003.1), which is based in part in the ISO C standard (ISO/IEC 9899). This chapter explains how to use this API and examines some of its pitfalls and shortcomings.

Chapter 10, “FAT File System”. This chapter details the low-level architecture of the FAT file system. Though the API of μ C/FS is file system agnostic, the file system type does affect performance, reliability and security, as explained here as well.

Chapter 9, “Device Drivers”. All hardware accesses are eventually performed by a device driver. This chapter describes the drivers available with μ C/FS and broadly profiles supported media types in terms of cost, performance and complexity.

Chapter 11, “RAM Disk Driver”. This chapter demonstrates the use of the simplest storage medium, the RAM disk.

Chapter 12, “SD/MMC Drivers”. SD and MMC cards are flash-based removable storage devices commonly used in consumer electronics. For embedded CPUs, a SD/MMC card is an appealing medium because of its simple and widely-supported physical interfaces (one choice is SPI). This chapter describes the interface and function of these devices.

Chapter 13, “NAND Flash Driver”. NAND flash is the first category of flash media. Write speeds are fast (compared to NOR flash), at the expense of slower read speeds and complexities such as bit-errors and page program limitations. This chapter describes the functions of these devices and the architecture of the supporting driver.

Chapter 14, “NOR Flash Driver”. NOR flash is the second category of flash media. They suffer slow write speeds, balanced with blazingly-fast read speeds. Importantly, they are not plagued by the complications of NAND flash, which simplifies interfacing with them. This chapter describes the function of these devices and the architecture of the supporting driver.

Chapter 15, “MSC Driver”. The now-common USB drive implements the Mass Storage Class (MSC) protocol, and a CPU with a USB host interface can access these devices with appropriate software. The MSC driver, discussed in this chapter, with μ C/USB-Host is just such appropriate software.

Appendix A, “ μ C/FS API Reference”. The reference manual describes every API function. The arguments and return value of each function are given, supplemented by notes about its use and an example code listing.

Appendix B, “ μ C/FS Error Codes”. This appendix provides a brief explanation of μ C/FS error codes defined in `fs_err.h`.

Appendix C, “ μ C/FS Porting Manual”. The portability of μ C/FS relies upon ports to interface between its modules and the platform or environment. Most of the ports constitute the board support package (BSP), which is interposed between the file system suite (or driver) and hardware. The OS port adapts the software to a particular OS kernel. The porting manual describes each port function.

Appendix D, “ μ C/FS Types and Structures”. This appendix provides a reference to the μ C/FS types and structures.

Appendix E, “ μ C/FS Configuration”. μ C/FS is configured via defines in a single configuration file, `fs_cfg.h`. The configuration manual specifies each define and the meaning of possible values.

Appendix F, “Shell Commands”. A familiar method of accessing a file system, at least to engineers and computer scientists, is the command line. In an embedded system, a UART is a port over which commands can be executed easily, even for debug purposes. A set of shell commands have been developed for μ C/FS that mirror the syntax of UNIX utilities, as described in this chapter.

Appendix G, “Bibliography”.

Appendix H, “ μ C/FS Licensing Policy”.

Chapter

2

μC/FS Architecture

μC/FS was written from the ground up to be modular and easy to adapt to different CPUs (Central Processing Units), RTOSs (Real-Time Operating Systems), storage media and compilers. Figure 2-1 shows a simplified block diagram of the different μC/FS modules and their relationships.

Notice that all of the μC/FS files start with `'fs_'`. This convention allows you to quickly identify which files belong to μC/FS. Also note that all functions and global variables start with `'FS'`, and all macros and `#defines` start with `'FS_'`.

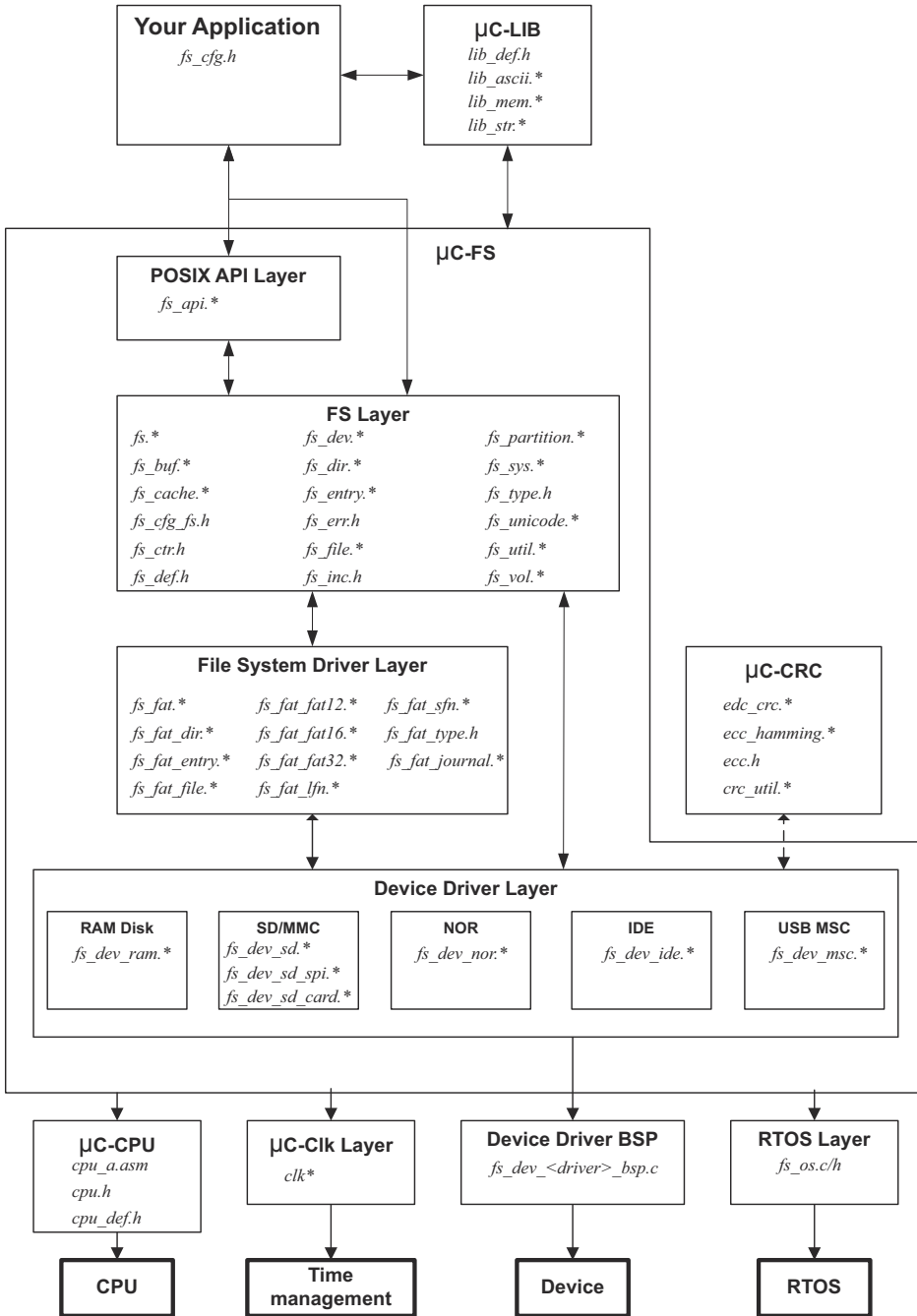

Figure 2-1 μC/FS architecture

2-1 ARCHITECTURE COMPONENTS

μ C/FS consists of a set of modular software components. It also requires a few external components (provided with the release) be compiled into the application and a few configuration and BSP files be adapted to the application.

2-1-1 YOUR APPLICATION

Your application needs to provide configuration information to μ C/FS in the form of one C header file named `fs_cfg.h`.

Some of the configuration data in `fs_cfg.h` consist of specifying whether certain features will be present. For example, LFN support, volume cache and file buffering are all enabled or disabled in this file. In all, there are about 30 `#define` to set. However, most of these can be set to their default values.

2-1-2 μ C-LIB (LIBRARIES)

Because μ C/FS is designed to be used in safety critical applications, all 'standard' library functions like `strcpy()`, `memset()`, etc., have been re-written to follow the same quality as the rest of the file system software.

2-1-3 POSIX API LAYER

Your application interfaces to μ C/FS using the well-known `stdio.h` API (Application Programming Interface). Alternately, you can use μ C/FS's own file and directory interface functions. Basically, POSIX API layer is a layer of software that converts POSIX file access calls to μ C/FS file access calls.

2-1-4 FS LAYER

This layer contains most of the CPU-, RTOS- and compiler-independent code for μ C/FS. There are three categories of files in this section:

- 1 File system object-specific files:
 - Devices (`fs_dev.*`)
 - Directories (`fs_dir.*`)
 - Entries (`fs_entry.*`)
 - Files (`fs_file.*`)
 - Partitions (`fs_partition.*`)
 - Volumes (`fs_vol.*`)
- 2 Support files:
 - Buffer management (`fs_buf.*`)
 - Cache management (`fs_cache.*`)
 - Counter management (`fs_ctr.h`)
 - File system driver (`fs_sys.*`)
 - Unicode encoding support (`fs_unicode.*`)
 - Utility functions (`fs_util.*`)
- 3 Miscellaneous header files:
 - Master μ C/FS header file (`fs.h`)
 - Error codes (`fs_err.h`)
 - Aggregate header file (`fs_inc.h`)
 - Miscellaneous data types (`fs_type.h`)
 - Miscellaneous definitions (`fs_def.h`)
 - Configuration definitions (`fs_cfg_fs.h`)

2-1-5 FILE SYSTEM DRIVER LAYER

The file system driver layer understands the organization of a particular file system type, such as FAT. The current version of μ C/FS only supports FAT file systems. `fs_fat*.*` contains the file system driver which should be used for FAT12/FAT16/FAT32 disks with or without Long File Name (LFN) support.

2-1-6 DEVICE DRIVER LAYER

The device driver layer understands about types of file system media (SD/MMC card, NOR flash, etc.). In order for the device drivers to be independent of your CPU, we use additional files to encapsulate such details as the access of registers, reading and writing to a data bus and setting clock rates.

Each device driver is named according to the pattern

```
fs_dev_<dev drv name>.c
```

where `<dev drv name>` is the an identifier for the device driver. For example, the driver for SD/MMC cards using SPI mode is called `fs_dev_sd_spi.c`. Most device drivers require a BSP layer, with code for accessing registers, reading from or writing to a data bus, etc. This file is named according to the pattern

```
fs_dev_<dev drv name>_bsp.c
```

For example, `fs_dev_sd_spi_bsp.c` contains the BSP functions for the driver SD/MMC cards using SPI mode.

2-1-7 μ C-CPU

μ C/FS can work with either an 8, 16, 32 or even 64-bit CPU, but needs to have information about the CPU you are using. The μ C-CPU layer defines such things as the C data type corresponding to 16-bit and 32-bit variables, whether the CPU is little- or big-endian and, how interrupts are disabled and enabled on the CPU, etc.

CPU specific files are found in the `...\uC-CPU` directory and, in order to adapt μ C/FS to a different CPU, you would need to either modify the `cpu*. *` files or, create new ones based on the ones supplied in the `uC-CPU` directory. In general, it's much easier to modify existing files because you have a better chance of not forgetting anything.

2-1-8 RTOS LAYER

μ C/FS does not require an RTOS. However, if μ C/FS is used with an RTOS, a set of functions must be implemented to prevent simultaneous access of devices and core μ C/FS structures by multiple tasks.

μ C/FS is provided with a no-RTOS (which contains just empty functions), a μ C/OS-II and a μ C/OS-III interface. If you use a different RTOS, you can use the `fs_os. *` for μ C/OS-II as a template to interface to the RTOS of your choice.

μC/FS Directories and Files

μC/FS is fairly easy to use once you understand which source files are needed to make up a μC/FS-based application. This chapter will discuss the modules available for μC/FS and how everything fits together.

Figure 3-1 shows the μC/FS architecture and its relationship with the hardware. Memory devices may include actual media both removable (SD/MMC, CF cards) and fixed (NAND flash, NOR flash) as well as any controllers for such devices. Of course, your hardware would most likely contain other devices such as UARTs (Universal Asynchronous Receiver Transmitters), ADCs (Analog to Digital Converters) and Ethernet controller(s). Moreover, your application may include other middleware components like an OS kernel, networking (TCP/IP) stack or USB stack that may integrate with μC/FS.

A Windows™-based development platform is assumed. The directories and files make references to typical Windows-type directory structures. However, since μC/FS is available in source form then it can certainly be used on Unix, Linux or other development platforms. This, of course, assumes that you are a valid μC/FS licensee in order to obtain the source code.

The names of the files are shown in upper case to make them ‘stand out’. The file names, however, are actually lower case.

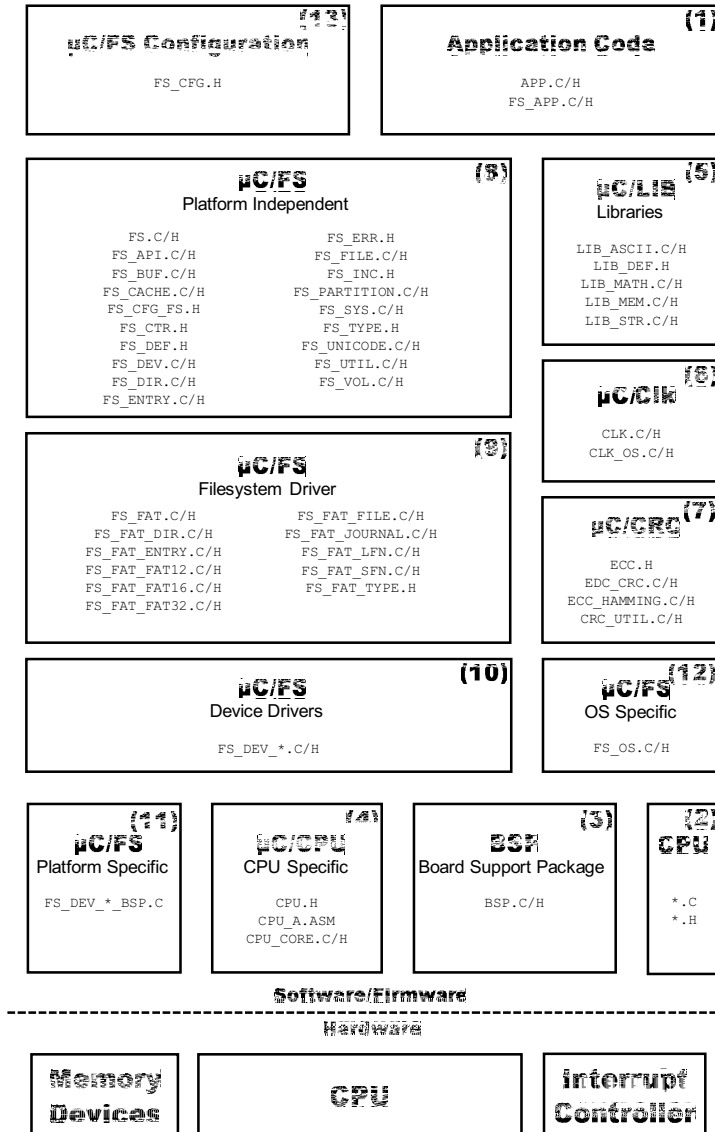

Figure 3-1 µC/FS Architecture

F3-1(1) The application code consist of project or product files. For convenience, we simply called these `app.c` and `app.h` but your application can contain any number of files and they do not have to be called `app.*`. The application code is typically where you would find `main()`.

-
- F3-1(2) Quite often, semiconductor manufacturers provide library functions in source form for accessing the peripherals on their CPU (Central Processing Unit) or MCU (Micro Controller Unit). These libraries are quite useful and often save valuable time. Since there is no naming convention for these files, *.c and *.h are assumed.
- F3-1(3) The Board Support Package (BSP) is code that you would typically write to interface to peripherals on your target board. For example you can have code to turn on and off LEDs (light emitting diodes), functions to turn on and off relays, and code to read switches and temperature sensors.
- F3-1(4) μ C/CPU is an abstraction of basic CPU-specific functionality. These files define functions to disable and enable interrupts, data types (e.g., `CPU_INT08U`, `CPU_FP32`) independent of the CPU and compiler and many more functions.
- F3-1(5) μ C/LIB consists of a group of source files to provide common functions for memory copy, string manipulation and character mapping. Some of the functions replace `stdlib` functions provided by the compiler. These are provided to ensure that they are fully portable from application to application and (most importantly) from compiler to compiler.
- F3-1(6) μ C/Clk is an independant clock/calendar management module, with source code for easily managing date and time in a product. μ C/FS uses the date and time information from μ C/Clk to update files and directories with the proper creation/modification/access time.
- F3-1(7) μ C/CRC is a stand-alone module for calculating checksums and error correction codes. This module is used by some of μ C/FS device drivers.
- F3-1(8) This is the μ C/FS platform-independent code, free of dependencies on CPU and memory device. This code is written in highly-portable ANSI C code. This code is only available to μ C/FS licensees.
- F3-1(9) This is the μ C/FS system driver for FAT file systems. This code is only available to μ C/FS licensees.

- F3-1(10) This is the collection of device drivers for μ C/FS. Each driver supports a certain device type, such as SD/MMC cards, NAND flash or NOR flash. Drivers are only available to μ C/FS licensees.
- F3-1(11) This is the μ C/FS code that is adapted to a specific platform. It consists of small code modules written for specific drivers called ports that must be adapted to the memory device controllers or peripherals integrated into or attached to the CPU. The requirements for these ports are described in Appendix C, Porting Manual.
- F3-1(12) μ C/FS does not require an RTOS. However, if μ C/FS is used with an RTOS, a set of functions must be implemented to prevent simultaneous access of devices and core μ C/FS structures by multiple tasks.
- F3-1(13) This μ C/FS configuration file defines which μ C/FS features (`fs_cfg.h`) are included in the application.

3-1 APPLICATION CODE

When Micrium provides you with example projects, we typically place those in a directory structure as shown below. Of course, you can use whatever directory structure suits your project/product.

```
\Micrium
  \Software
    \EvalBoards
      \<manufacturer>
        \<board name>
          \<compiler>
            \<project name>
              \*.*
```

\Micrium

This is where we place all software components and projects provided by Micrium. This directory generally starts from the root directory of your computer.

\Software

This sub-directory contains all the software components and projects.

\EvalBoards

This sub-directory contains all the projects related to the evaluation boards supported by Micrium.

\<manufacturer>

Is the name of the manufacturer of the evaluation board. The '<' and '>' are not part of the actual name.

\<board name>

This is the name of the evaluation board. A board from Micrium will typically be called uC-Eval-xxxx where 'xxxx' will represent the CPU or MCU used on the evaluation board. The '<' and '>' are not part of the actual name.

\<compiler>

This is the name of the compiler or compiler manufacturer used to build the code for the evaluation board. The '<' and '>' are not part of the actual name.

\<project name>

This is the name of the project that will be demonstrated. For example a simple μ C/FS project might have a project name of 'FS-Ex1'. The '-Ex1' represents a project containing only μ C/FS. A project name of FS-Probe-Ex1 would represent a project containing μ C/FS as well as μ C/Probe. The '<' and '>' are not part of the actual name.

.

These are the source files for the project/product. You are certainly welcomed to call the main files APP*.* for your own projects but you don't have to. This directory also contains the configuration file **FS_CFG.H** and other files as needed by the project.

3-2 CPU

As shown below is the directory where we place semiconductor manufacturer peripheral interface source files. Of course, you can use whatever directory structure suits your project/product.

```
\Micrium
  \Software
    \CPU
      \<manufacturer>
        \<architecture>
          \*.*
```

\Micrium

This is where we place all software components and projects provided by Micrium.

\Software

This sub-directory contains all the software components and projects.

\CPU

This sub-directory is always called CPU.

\<manufacturer>

Is the name of the semiconductor manufacturer who provided the peripheral library. The '<' and '>' are not part of the actual name.

\<architecture>

This is the name of the specific library and is generally associated with a CPU name or an architecture.

.

These are the library source files. The names of the files are determined by the semiconductor manufacturer.

3-3 BOARD SUPPORT PACKAGE (BSP)

The BSP is generally found with the evaluation or target board because the BSP is specific to that board. In fact, if well written, the BSP should be used for multiple projects.

```
\Micrium
  \Software
    \EvalBoards
      \<manufacturer>
        \<board name>
          \<compiler>
            \BSP
              \*.*
```

\Micrium

This is where we place all software components and projects provided by Micrium.

\Software

This sub-directory contains all the software components and projects.

\EvalBoards

This sub-directory contains all the projects related to evaluation boards.

\<manufacturer>

Is the name of the manufacturer of the evaluation board. The '<' and '>' are not part of the actual name.

\<board name>

This is the name of the evaluation board. A board from Micrium will typically be called uC Eval xxxx where 'xxxx' will be the name of the CPU or MCU used on the evaluation board. The '<' and '>' are not part of the actual name.

\<compiler>

This is the name of the compiler or compiler manufacturer used to build the code for the evaluation board. The '<' and '>' are not part of the actual name.

\BSP

This directory is always called BSP.

.

These are the source files of the BSP. Typically all the file names start with BSP_ but they don't have to. It's thus typical to find **bsp.c** and **bsp.h** in this directory. Again, the BSP code should contain functions such as LED control functions, initialization of timers, interface to Ethernet controllers and more.

3-4 μ C/CPU, CPU SPECIFIC SOURCE CODE

μ C/CPU consists of files that encapsulate common CPU-specific functionality as well as CPU- and compiler-specific data types.

```
\Micrium
  \Software
    \uC-CPU
      \cpu_core.c
      \cpu_core.h
      \cpu_def.h
      \Cfg\Template
        \cpu_cfg.h
      \<architecture>
        \<compiler>
          \cpu.h
          \cpu_a.asm
          \cpu_c.c
```

\Micrium

This directory contains all software components and projects provided by Micrium.

\Software

This sub-directory contains all the software components and projects.

\uC-CPU

This is the main μ C/CPU directory.

cpu_core.c contains C code that is common to all CPU architectures. Specifically, this file contains functions to measure the interrupt disable time of the `CPU_CRITICAL_ENTER()` and `CPU_CRITICAL_EXIT()` macros, a function that emulates a count leading zeros instruction and a few other functions.

cpu_core.h contains the function prototypes of the functions provided in `cpu_core.c` as well as allocation of the variables used by this module to measure interrupt disable time.

cpu_def.h contains miscellaneous #define constants used by the μC/CPU module.

\Cfg\Template

This directory contains a configuration template file (`cpu_cfg.h`) that you will need to copy to your application directory in order to configure the μC/CPU module based on your application requirements.

cpu_cfg.h determines whether you will enable measurement of the interrupt disable time, whether your CPU implements a count leading zeros instruction in assembly language or whether it will need to be emulated in C and more.

\<architecture>

This is the name of the CPU architecture for which μC/CPU was ported to. The ‘<’ and ‘>’ are not part of the actual name.

\<compiler>

This is the name of the compiler or compiler manufacturer used to build the code for the μC/CPU port. The ‘<’ and ‘>’ are not part of the actual name.

The files in this directory contain the μC/CPU port.

cpu.h contains type definitions to make μC/FS and other modules independent of the CPU and compiler word sizes. Specifically, you will find the declaration of the `CPU_INT16U`, `CPU_INT32U`, `CPU_FP32` and many other data types. Also, this file specifies whether the CPU is a big- or little-endian machine and contains function prototypes for functions that are specific to the CPU architecture and more.

cpu_a.asm contains the assembly language functions to implement the code to disable and enable CPU interrupts, count leading zeros (if the CPU supports that instruction) and other CPU specific functions that can only be written in assembly language. This file could also contain code to enable caches, setup MPUs and MMU and more. The functions provided in this file are accessible from C.

cpu_c.c contains C code of functions that are specific to the specific CPU architecture but written in C for portability. As a general rule, if a function can be written in C then it should, unless there are significant performance benefits by writing it in assembly language.

3-5 μ C/LIB, PORTABLE LIBRARY FUNCTIONS

μ C/LIB consists of library functions that are meant to be highly portable and not tied to any specific compiler. This was done to facilitate third party certification of Micrium products.

```
\Micrium
  \Software
    \uC-LIB
      \lib_ascii.c
      \lib_ascii.h
      \lib_def.h
      \lib_math.c
      \lib_math.h
      \lib_mem.c
      \lib_mem.h
      \lib_str.c
      \lib_str.h
      \Cfg\Template
        \lib_cfg.h
      \Ports
        \<architecture>
          \<compiler>
            \lib_mem_a.asm
```

\Micrium

This directory contains all software components and projects provided by Micrium.

\Software

This sub-directory contains all the software components and projects.

\uC-LIB

This is the main μC/LIB directory.

\Cfg\Template

This directory contains a configuration template file (**lib_cfg.h**) that must be copied to the application directory to configure the μC/LIB module based on application requirements.

lib_cfg.h determines whether to enable assembly-language optimization (assuming there is an assembly-language file for the processor, i.e. **lib_mem_a.asm**) and a few other #defines.

3-6 μC/CLK, TIME/CALENDAR MANAGEMENT

μC/Clk consists of functions that are meant to centralize time management in one independent module. This way, the same time info can be easily shared across all Micrium products.

```
\Micrium
  \Software
    \uC-Clk
      \Cfg
        \Template
          \clk_cfg.h
      \OS
        \<rtos_name>
          \clk_os.c
    \Source
      \clk.c
      \clk.h
```

\Micrium

This directory contains all software components and projects provided by Micrium.

\Software

This sub-directory contains all the software components and projects.

\uC-Clk

This is the main μ C/Clk directory.

\Cfg\Template

This directory contains a configuration template file (**clk_cfg.h**) that must be copied to the application directory to configure the μ C/Clk module based on application requirements.

clk_cfg.h determines whether clock will be managed by the RTOS or in your application. A few other #defines are used to enable/disable some features of μ C/Clk and to configure some parameteres, like the clock frequency.

\OS

This is the main OS directory.

\<rtos_name>

This is the directory that contains the file to perform RTOS abstraction. Note that the file for the selected RTOS abstraction layer must always be named **clk_os.c**.

μ C/Clk has been tested with μ C/OS-II, μ C/OS-III and the RTOS layer files for these RTOS are found in the following directories:

```
\Micrium\Software\uC-Clk\OS\uCOS-II\clk_os.c
```

```
\Micrium\Software\uC-Clk\OS\uCOS-III\clk_os.c
```

\Source

This directory contains the CPU-independant source code for μ C/Clk. All file in this directory should be included in the build (assuming the presence of the source code). Features that are not required will be compiled out based on the value of #define constants in **clk_cfg.h**.

3-7 μC/CRC, CHECKSUMS AND ERROR CORRECTION CODES

μC/CRC consists of functions to compute different error detection and correction codes. The functions are speed-optimized to avoid the important impact on performances that these CPU-intensive calculations may present.

```
\Micrium
  \Software
    \uC-CRC
      \Cfg
        \Template
          \crc_cfg.h
        \Ports
          \<architecture>
            \<compiler>
              \ecc_hamming_a.asm
              \edc_crc_a.asm
        \Source
          \edc_crc.h
          \edc_crc.c
          \ecc_hamming.h
          \ecc_hamming.c
          \ecc.h
          \crc_util.h
          \crc_util.c
```

\Micrium

This directory contains all software components and projects provided by Micrium.

\Software

This sub-directory contains all the software components and projects.

\uC-CRC

This is the main μC/CRC directory.

\Cfg\Template

This directory contains a configuration template file (**crc_cfg.h**) that must be copied to the application directory to configure the μC/CRC module based on application requirements.

crc_cfg.h determines whether to enable assembly-language optimization (assuming there is an assembly-language file for the processor) and a few other #defines.

\<architecture>

The name of the CPU architecture that μ C/CRC was ported to. The '<' and '>' are not part of the actual name.

\<compiler>

The name of the compiler or compiler manufacturer used to build code for the μ C/CRC port. The '<' and '>' are not part of the actual name.

ecc_hamming_a.asm contains the assembly language functions to optimize the calculation speed of Hamming code.

edc_crc_a.asm contains the assembly language functions to optimize the calculation speed of CRC (cyclic redundancy checks).

\Source

This is the directory that contains all the CPU independent source code files. of μ C/CRC.

3-8 μ C/FS PLATFORM-INDEPENDENT SOURCE CODE

The files in these directories are available to μ C/FS licensees (see Appendix H, Licensing Policy).

```
\Micrium
  \Software
    \uC-FS
      \APP\Template
        \fs_app.c
        \fs_app.h
      \Cfg\Template
        \fs_cfg.h
      \OS\Template
        \fs_os.c
        \fs_os.h
```

```
\Source
  \fs_c
  \fs.h
  \fs_api.c
  \fs_api.h
  \fs_buf.c
  \fs_buf.h
  \fs_cache.c
  \fs_cache.h
  \fs_cfg_fs.h
  \fs_ctr.h
  \fs_def.h
  \fs_dev.c
  \fs_dev.h
  \fs_dir.c
  \fs_dir.h
  \fs_entry.c
  \fs_entry.h
  \fs_err.h
  \fs_file.c
  \fs_file.h
  \fs_inc.h
  \fs_partition.c
  \fs_partition.h
  \fs_sys.c
  \fs_sys.h
  \fs_type.h
  \fs_unicode.c
  \fs_unicode.h
  \fs_util.c
  \fs_util.h
  \fs_vol.c
  \fs_vol.h
```

\Micrium

This is where we place all software components and projects provided by Micrium.

\Software

This sub-directory contains all the software components and projects.

\uC-FS

This is the main μ C/FS directory.

\APP\Template

This directory contains a template of the code for initializing the file system.

\Cfg\Template

This directory contains a configuration template file (`lib_cfg.h`) that is required to be copied to the application directory to configure the μ C/FS module based on application requirements.

fs_cfg.h specifies which features of μ C/FS you want in your application. If μ C/FS is provided in linkable object code format then this file will be provided to show you what features are available in the object file. See Appendix B, μ C/FS Configuration Manual.

\Source

This directory contains the platform-independent source code for μ C/FS. All the files in this directory should be included in your build (assuming you have the source code). Features that you don't want will be compiled out based on the value of `#define` constants in `fs_cfg.h`.

fs.c/h contains core functionality for μ C/FS including `FS_Init()` (called to initialize μ C/FS) and `FS_WorkingDirSet()/FS_WorkingDirGet()` (used to get and set the working directory).

fs_api.c/h contains the code for the POSIX-compatible API. See Chapter x, API for details about the POSIX-compatible API.

fs_buf.c/h contains the code for the buffer management (used internally by μ C/FS).

fs_dev.c/h contains code for device management. See Chapter x, Devices for details about devices.

fs_dir.c/h contains code for directory access. See Chapter x, Directories for details about directory access.

fs_entry.c/h contains code for entry access. See Chapter x, Entries for details about entry access.

fs_file.c/h contains code for file access. See Chapter x, Files for details about file access.

fs_inc.h is a master include file that includes all

fs_sys.c/h contains the code for system driver management (used internally by μC/FS).

fs_unicode.c/h contains the code for handling Unicode strings (used internally by μC/FS).

3-9 μC/FS FAT FILESYSTEM SOURCE CODE

The files in these directories are available to μC/FS licensees (see Appendix H, Licensing Policy).

```
\Micrium
  \Software
    \uC-FS
      \FAT
        \fs_fat.c
        \fs_fat.h
        \fs_fat_dir.c
        \fs_fat_dir.h
        \fs_fat_entry.c
        \fs_fat_entry.h
        \fs_fat_fat12.c
        \fs_fat_fat12.h
        \fs_fat_fat16.c
        \fs_fat_fat16.h
        \fs_fat_fat32.c
```

```
\fs_fat_fat32.h
\fs_fat_file.c
\fs_fat_file.h
\fs_fat_journal.c
\fs_fat_journal.h
\fs_fat_lfn.c
\fs_fat_lfn.h
\fs_fat_sfn.c
\fs_fat_sfn.h
\fs_fat_type.h
```

\Micrium

This is where we place all software components and projects provided by Micrium.

\Software

This sub-directory contains all the software components and projects.

\uC-FS

This is the main μ C/FS directory.

\FAT

This directory contains the FAT system driver for μ C/FS. All the files in this directory should be included in your build (assuming you have the source code).

3-10 μ C/FS MEMORY DEVICE DRIVERS

These files are generic drivers to use with different memory devices.

```
\Micrium
  \Software
    \uC-FS
      \Dev
        \MSC
          \fs_dev_msc.c
          \fs_dev_msc.h
        \NAND
```

```
\fs_dev_nand.c
\fs_dev_nand.h
\Ctrlr
    \fs_dev_nand_ctrlr_gen.c
    \fs_dev_nand_ctrlr_gen.h
    \fs_dev_nand_ctrlr_gen_soft_ecc.c
    \fs_dev_nand_ctrlr_gen_soft_ecc.h
    \fs_dev_nand_ctrlr_gen_micron_ecc.c
    \fs_dev_nand_ctrlr_gen_micron_ecc.h
\Part
    \fs_dev_nand_part_static.c
    \fs_dev_nand_part_static.h
    \fs_dev_nand_part_onfi.c
    \fs_dev_nand_part_onfi.h
\Cfg\Template
    fs_dev_nand_cfg.h
\BSP\Template
    \fs_dev_nand_ctrlr_gen_bsp.c
\NOR
    \fs_dev_nor.c
    \fs_dev_nor.h
\PHY
    \fs_dev_nor_amd_1x08.c
    \fs_dev_nor_amd_1x08.h
    \fs_dev_nor_amd_1x16.c
    \fs_dev_nor_amd_1x16.h
    \fs_dev_nor_intel.c
    \fs_dev_nor_intel.h
    \fs_dev_nor_sst25.c
    \fs_dev_nor_sst25.h
    \fs_dev_nor_sst39.c
    \fs_dev_nor_sst39.h
    \fs_dev_nor_stm25.c
    \fs_dev_nor_stm25.h
    \fs_dev_nor_stm29_1x08.c
    \fs_dev_nor_stm29_1x08.h
    \fs_dev_nor_stm29_1x16.c
    \fs_dev_nor_stm29_1x16.h
```

```
    \Template
        \fs_dev_nor_template.c
        \fs_dev_nor_template.h
    \BSP\Template
        \fs_dev_nor_bsp.c
    \BSP\Template (SPI GPIO)
        \fs_dev_nor_bsp.c
    \BSP\Template (SPI)
        \fs_dev_nor_bsp.c
\RAMDisk
    \fs_dev_ram.c
    \fs_dev_ram.h
\SD
    \fs_dev_sd.c
    \fs_dev_sd.h
\Card
    \fs_dev_sd_card.c
    \fs_dev_sd_card.h
    \BSP\Template
        \fs_dev_sd_card_bsp.c
\SPI
    \fs_dev_sd_spi.c
    \fs_dev_sd_spi.h
    \BSP\Template
        \fs_dev_sd_spi.bsp.c
\Template
    \fs_dev_template.c
    \fs_dev_template.h
```

\Micrium

This directory contains all software components and projects provided by Micrium.

\Software

This sub-directory contains all the software components and projects.

\uC-FS

This is the main μ C/FS directory.

\Dev

This is where you will find the device driver files for the storage devices you are planning on using.

\MSC

This directory contains the MSC (Mass Storage Class - USB drives) driver files.

fs_dev_msc.* are device driver for MSC devices. This driver is designed to work with μC/USB host stack.

For more details on this driver, please refer to Chapter 15, “MSC Driver” on page 219.

\NAND

This directory contains the NAND driver files.

fs_dev_nand.* are the device driver for NAND devices. These files require a set of controller-layer functions (defined in a file named **fs_dev_nand_ctrlr_<type>.***) as well as BSP functions specific to particular hardware and associated with chosen controller-layer (to be defined in a file named **fs_dev_nand_ctrlr_<type>_bsp.c**).

Note that in the case of the “generic” controller-layer implementation, some controller extensions files (defined in files named **fs_dev_nand_ctrlr_<ext_name>.***) may also be required.

For more details on this driver, please refer to Chapter 13, “NAND Flash Driver” on page 159.

\NOR

This directory contains the NOR driver files.

fs_dev_nor.* are the device driver for NOR devices. These files require a set of physical-layer functions (defined in a file name **fs_dev_nor_<physical type>.***) as well as BSP functions (to be defined in a file named **fs_dev_nor_bsp.c**) to work with a particular hardware setup.

For more details on this driver, please refer to Chapter 14, “NOR Flash Driver” on page 199.

\RAMDisk

This directory contains the RAM disk driver files.

fs_dev_ramdisk.* constitute the RAM disk driver.

For more details on this driver, please refer to Chapter 11, “RAM Disk Driver” on page 131.

\SD

This directory contains the SD/MMC driver files.

fs_dev_sd.* are device driver for SD devices. These files require to be used with either the **fs_dev_sd_spi.*** (for SPI/one-wire mode) or **fs_dev_sd_card.*** (for Card/4-wires mode) files. These files require a set of BSP functions to be defined in a file named either **fs_dev_sd_spi_bsp.c** or **fs_dev_sd_card_bsp.c** to work with a particular hardware setup.

For more details on this driver, please refer to Chapter 12, “SD/MMC Drivers” on page 135.

3-11 μ C/FS PLATFORM-SPECIFIC SOURCE CODE

These files are provided by the μ C/FS device driver developer. See Chapter 17, Porting μ C/FS. However, the μ C/FS source code is delivered with port examples.

```
\Micrium
  \Software
    \uC-FS
      \Examples
        \BSP
          \Dev
            <memory type>
              <manufacturer>
                <board name>
                  \fs_dev_<memory type>_bsp.c
```

\Micrium

This directory contains all software components and projects provided by Micrium.

\Software

This sub-directory contains all the software components and projects.

\uC-FS

This is the main µC/FS directory.

\Examples

This is where you will find the device driver BSP example files.

\Dev*<memory type>*

This is where you will find the examples BSP for one memory type. The '*<*' and '*>*' are not part of the actual name. The memory types supported by µC/FS are the following: NAND, NOR, SD\CARD, SD\SPI.

<manufacturer>

The name of the manufacturer of the evaluation board. The '*<*' and '*>*' are not part of the actual name.

3-12 µC/FS OS ABSTRACTION LAYER

This directory contains the RTOS abstraction layer which allows the use of µC/FS with nearly any commercial or in-house RTOS, or without any RTOS at all. The abstraction layer for the selected RTOS is placed in a sub-directory under OS as follows:

```
\Micrium
  \Software
    \uC-FS
      \OS
        \<rtos_name>
          \fs_os.c
          \fs_os.h
```

\Micrium

This directory contains all software components and projects provided by Micrium.

\Software

This sub-directory contains all the software components and projects.

\uC-FS

This is the main μ C/FS directory.

\OS

This is the main OS directory.

\<rtos_name>

This is the directory that contains the files to perform RTOS abstraction. Note that files for the selected RTOS abstraction layer must always be named **fs_os.***.

μ C/FS has been tested with μ C/OS-II, μ C/OS-III and without an RTOS. The RTOS layer files are found in the following directories:

```
\Micrium\Software\uC-Clk\OS\None\fs_os.*
\Micrium\Software\uC-Clk\OS\Template\fs_os.*
\Micrium\Software\uC-Clk\OS\uCOS-II\fs_os.*
\Micrium\Software\uC-Clk\OS\uCOS-III\fs_os.*
```

3-13 SUMMARY

Below is a summary of all the directories and files involved in a μ C/FS-based project. The '<-Cfg' on the far right indicates that these files are typically copied into the application (i.e., project) directory and edited based on project requirements.

```
\Micrium
  \Software
    \EvalBoards
      \<manufacturer>
        \<board name>
          \<compiler>
            \<project name>
              \app.c
              \app.h
              \other
            \BSP
              \bsp.c
              \bsp.h
```

```

        \other
\CPU
  \<manufacturer>
    \<architecture>
      \*.*
\uC-FS
  \APP\Template
    \fs_app.c           <-Cfg
    \fs_app.h           <-Cfg
  \CFG\Template
    \fs_cfg.h           <-Cfg
  \Dev

\MSC
  \fs_dev_msc.c
  \fs_dev_msc.h
\NAND
  \fs_dev_nand.c
  \fs_dev_nand.h
  \Ctrlr
    \fs_dev_nand_ctrlr_gen.c
    \fs_dev_nand_ctrlr_gen.h
    \fs_dev_nand_ctrlr_gen_soft_ecc.c
    \fs_dev_nand_ctrlr_gen_soft_ecc.h
    \fs_dev_nand_ctrlr_gen_micron_ecc.c
    \fs_dev_nand_ctrlr_gen_micron_ecc.h
  \Part
    \fs_dev_nand_part_static.c
    \fs_dev_nand_part_static.h
    \fs_dev_nand_part_onfi.c
    \fs_dev_nand_part_onfi.h
  \Cfg\Template
    fs_dev_nand_cfg.h
  \BSP\Template
    \fs_dev_nand_ctrlr_gen_bsp.c
\NOR
  \fs_dev_nor.c
  \fs_dev_nor.h

```

```
\PHY
  \fs_dev_nor_amd_1x08.c
  \fs_dev_nor_amd_1x08.h
  \fs_dev_nor_amd_1x16.c
  \fs_dev_nor_amd_1x16.h
  \fs_dev_nor_intel.c
  \fs_dev_nor_intel.h
  \fs_dev_nor_sst25.c
  \fs_dev_nor_sst25.h
  \fs_dev_nor_sst39.c
  \fs_dev_nor_sst39.h
  \fs_dev_nor_stm25.c
  \fs_dev_nor_stm25.h
  \fs_dev_nor_stm29_1x08.c
  \fs_dev_nor_stm29_1x08.h
  \fs_dev_nor_stm29_1x16.c
  \fs_dev_nor_stm29_1x16.h
  \Template
    \fs_dev_nor_template.c      <-Cfg
    \fs_dev_nor_template.h      <-Cfg
  \BSP<template>
    \fs_dev_nor_bsp.c          <-Cfg
\RAMDisk
  \fs_dev_ram.c
  \fs_dev_ram.h
\SD
  \fs_dev_sd.c
  \fs_dev_sd.h
\Card
  \fs_dev_sd_card.c
  \fs_dev_sd_card.h
  \BSP\Template
    \fs_dev_sd_card_bsp.c      <-Cfg
\SPI
  \fs_dev_sd_spi.c
  \fs_dev_sd_spi.h
  \BSP\Template
    \fs_dev_sd_spi.bsp.c      <-Cfg
```

```
\Template
    \fs_dev_template.c          <-Cfg
    \fs_dev_template.h        <-Cfg
\FAT
    \fs_fat.c
    \fs_fat.h
    \fs_fat_dir.c
    \fs_fat_dir.h
    \fs_fat_entry.c
    \fs_fat_entry.h
    \fs_fat_fat12.c
    \fs_fat_fat12.h
    \fs_fat_fat16.c
    \fs_fat_fat16.h
    \fs_fat_fat32.c
    \fs_fat_fat32.h
    \fs_fat_file.c
    \fs_fat_file.h
    \fs_fat_journal.c
    \fs_fat_journal.h
    \fs_fat_lfn.c
    \fs_fat_lfn.h
    \fs_fat_sfn.c
    \fs_fat_sfn.h
    \fs_fat_type.h
\OS
    <template>
        \fs_os.c                <-Cfg
        \fs_os.h                <-Cfg
    <rtos_name>
        \fs_os.c
        \fs_os.h
\Source
    \fs_c
    \fs.h
    \fs_api.c
    \fs_api.h
    \fs_buf.c
```

```
\fs_buf.h
\fs_cache.c
\fs_cache.h
\fs_cfg_fs.h
\fs_ctr.h
\fs_def.h
\fs_dev.c
\fs_dev.h
\fs_dir.c
\fs_dir.h
\fs_entry.c
\fs_entry.h
\fs_err.h
\fs_file.c
\fs_file.h
\fs_inc.h
\fs_partition.c
\fs_partition.h
\fs_sys.c
\fs_sys.h
\fs_type.h
\fs_unicode.c
\fs_unicode.h
\fs_util.c
\fs_util.h
\fs_vol.c
\fs_vol.h
\OS
  \<architecture>
    \<compiler>
      \os_cpu.h
      \os_cpu_a.asm
      \os_cpu_c.c
\uC-CPU
  \cpu_core.c
  \cpu_core.h
  \cpu_def.h
  \Cfg\Template
```

```
    \cpu_cfg.h                <-Cfg
  \<architecture>
    \<compiler>
      \cpu.h
      \cpu_a.asm
      \cpu_c.c
\uC-Clk
  \Cfg
    \Template
      \clk_cfg.h              <-Cfg
  \OS
    \<rtos_name>
      \clk_os.c
  \Source
    \clk.c
    \clk.h
\uC-CRC
  \Cfg
    \Template
      \crc_cfg.h              <-Cfg
  \Ports
    \<architecture>
      \<compiler>
        \ecc_hamming_a.asm
        \edc_crc_a.asm
  \Source
    \edc_crc.h
    \edc_crc.c
    \ecc_hamming.h
    \ecc_hamming.c
    \ecc.h
\uC-LIB
  \lib_ascii.c
  \lib_ascii.h
  \lib_def.h
  \lib_math.c
  \lib_math.h
  \lib_mem.c
```

```
\lib_mem.h
lib_str.c
lib_str.h
\Cfg\Template
    lib_cfg.h                <-Cfg
```

Useful Information

4-1 NOMENCLATURE

This manual uses a set of terms to consistently describe operation of μ C/FS and its hardware and software environment. The following is a small list of these terms, with definitions.

A **file system suite** is software which can find and access files and directories. Using “file system suite” rather than “file system” eliminates any need for disambiguation among the second term’s several meanings, which include “a system for organizing directories and files”, “a collection of files and directories stored on a drive” and (commonly) the software which will be referred to as a file system suite. The term file system will always mean a collection of files and directories stored on a drive (or, in this document, volume).

A **device driver** (or just driver) is a code module which allows the general-purpose file system suite to access a specific type of device. A device driver is **registered** with the file system suite.

A **device** is an instance of a device type that is accessed using a device driver. An addressable area (typically of 512 bytes) on a device is a sector. A sector is the smallest area that (from the file system suite’s point of view) can be atomically read or written.

Several devices can use the same device driver. These are distinguished by each having a unique **unit number**. Consequently, `<DEVICE NAME>:<UNIT NUMBER>` is a unique device identifier if all devices are required to have unique names. That requirement is enforced in this file system suite.

A **logical device** is the combination of two or more separate devices. To form a logical device, the sector address spaces of the constituent devices are concatenated to form a single continuous address space.

A device can be **partitioned**, or subdivided into one or more regions (called **partitions**) each consisting of a number of consecutive sectors. Typically, structures are written to the device instructing software as to the location and size of these partitions. This file system suite supports **DOS partitions**.

A **volume** is a device or device partition with a file system. A device or device partition must go through a process called **mounting** to become a volume, which includes finding the file system and making it ready for use. The name by which a volume is addressed may also be called the volume's **mount point**.

A device or volume may be **formatted** to create a new file system on the device. For disambiguation purposes, this process is also referred to as **high-level formatting**. The volume or device will automatically be mounted once formatting completes.

For certain devices, it is either necessary or desirable to perform **low-level formatting**. This is the process of associating logical sector numbers with areas of the device.

A **file system driver** is a code module which allows the general-purpose file system suite to access a specific type of file system. For example, this file system suite includes a FAT file system driver.

FAT (File Allocation Table) is a common file system type, prevalent in removable media that must work with various OSs. It is named after its primary data structure, a large table that records what clusters of the disk are allocated. A **cluster**, or group of sectors, is the minimum data allocation unit of the FAT file system.

4-2 μC/FS DEVICE AND VOLUME NAMES

Devices are specified by name. For example, a device can be opened:

```
FSDev_Open("sd:0:", (void *)0, &err);
```

In this case, "sd:0:" is the device name. It is a concatenation of:

sd	The name of the device driver
:	A single colon
0	The unit number
:	A final colon

The unit number allows multiple devices of the same type; for example, there could be several SD/MMC devices connected to the CPU: "sd:0:", "sd:1", "sd:2"...

The maximum length of a device name is `FS_CFG_MAX_DEV_NAME_LEN`; this must be at least three characters larger than the maximum length of a device driver name, `FS_CFG_MAX_DEV_DRV_NAME_LEN`. A device name (or device driver name) must not contain the characters:

`: \ /`

Volumes are also specified by name. For example, a volume can be formatted:

```
FSVol_Fmt("vol:", (void *)0, &err);
```

Here, "vol:" is the volume name. μC/FS imposes no restrictions on these names, except that they must end with a colon (':'), must be no more than `FS_CFG_MAX_VOL_NAME_LEN` characters long, and must not contain either of the characters '\ ' or '/':

It is typical to name a volume the same as a device; for example, a volume may be opened:

```
FSVol_Open("sd:0:"          (a)
           "sd:0:"          (b)
           (void *)0,
           &err);
```

In this case, the name of the volume (a) is the same as the name as the device (b). When multiple volumes exist in the same application, the volume name should be prefixed to the file or directory path name:

```
p_file = fs_fopen("sd:0:\\dir01\\file01.txt", "w"); // File on SD card
p_file = fs_fopen("ram:0:\\dir01\\file01.txt", "w"); // File on RAM disk
```

4-3 μ C/FS FILE AND DIRECTORY NAMES AND PATHS

Files and directories are identified by a path string; for example, a file can be opened:

```
p_file = fs_fopen("\\test\\file001.txt", "w");
```

In this case, "\\test\\file001.txt" is the path string.

An application specifies the path of a file or directory using either an absolute or a relative path. An absolute path is a character string which specifies a unique file, and follows the pattern:

```
<vol_name>:<... Path ...><File>
```

where

<vol_name> is the name of the volume, identical to the string specified in `FSVol_Open()`.

<... Path ...> is the file path, which *must* always begin *and* end with a '\\.

<File> is the file (or leaf directory) name, including any extension.

For example:

```
p_file = fs_fopen("sd:0:\\file.txt", "w");           (a)
p_file = fs_fopen("\\file.txt", "w");              (b)
p_file = fs_fopen("sd:0:\\dir01\\file01.txt", "w"); (c)
p_file = fs_opendir("sd:0:\\")                     (d)
p_file = fs_opendir("\\")                          (e)
p_file = fs_opendir("sd:0:\\dir01\\")             (f)
```

Which demonstrate (a) opening a file in the root directory of a specified volume; (b) opening a file in the root directory on a default volume; (c) opening a file in a non-root directory; (d) opening the root directory of a specified volume; (e) opening the root directory of the default volume; (f) opening a non-root directory.

Relative paths can be used if working directories are enabled (`FS_CFG_WORKING_DIR_EN` is `DEF_ENABLED` — see Appendix E on page 501). A relative path begins with neither a volume name nor a ‘\’:

`<... Relative Path ...><File>`

where

`<... Relative Path ...>` is the file path, which must not begin with a ‘\’ *but* must end with a ‘\’.

`<File>` is the file (or leaf directory) name, including any extension.

Two special path components can be used. “..” moves the path to the parent directory. “.” keeps the path in the same directory (basically, it does nothing).

A relative path is appended to the current working directory of the calling task to form the absolute path of the file or directory. The working directory functions, `fs_chdir()` and `fs_getcwd()`, can be used to set and get the working directory.

4-4 μ C/FS NAME LENGTHS

The configuration constants `FS_CFG_MAX_PATH_NAME_LEN`, `FS_CFG_MAX_FILE_NAME_LEN` and `FS_CFG_MAX_VOL_NAME_LEN` in `fs_cfg.h` set the maximum length of path names, file names and volume names. The constant `FS_CFG_MAX_FULL_NAME_LEN` is defined in `fs_cfg_fs.h` to describe the maximum full name length. The path name begins with a path separator character and includes the file name; the file name is just the portion of the path name after the last (non-final) path separator character. The full name is composed of an explicit volume name (optional) and a path name; the maximum full name length can be calculated:

$$\text{FullNameLenmax} = \text{VolNameLenmax} + \text{PathNameLenmax}$$

Figure 2-3 demonstrates these definitions.

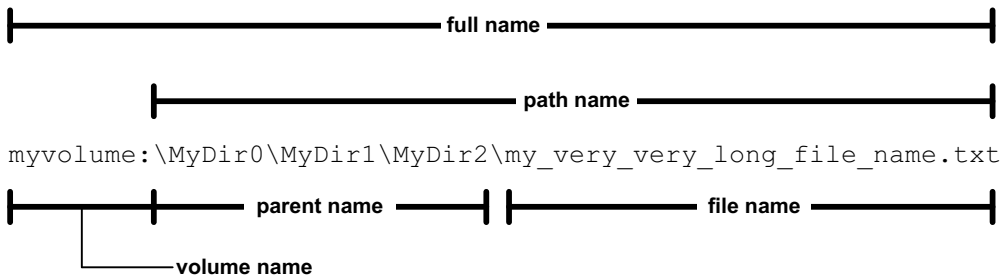

Figure 4-1 File, path and volume name lengths

No maximum parent name length is defined, though one may be derived. The parent name must be short enough so that the path of a file in the directory would be valid. Strictly, the minimum file name length is 1 character, though some OSs may enforce larger values (eleven on some Windows systems), thereby decreasing the maximum parent name length.

$$\text{ParentNameLenmax} = \text{PathNameLenmax} - \text{FileNameLenmin} - 1$$

The constants `FS_CFG_MAX_DEV_DRV_NAME_LEN` and `FS_CFG_MAX_DEV_NAME_LEN` in `fs_cfg.h` set the maximum length of device driver names and device names, as shown in Figure 2-4. The device name is between three and five characters longer than the device driver name, since the unit number (the integer between the colons of the device name) must be between 0 and 255.

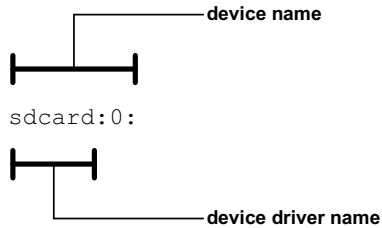

Figure 4-2 Device and device driver name lengths

Each of the maximum name length configurations specifies the maximum string length *without* the NULL character. Consequently, a buffer which holds one of these names must be one character longer than the define value.

4-5 RESOURCE USAGE

μ C/FS resource usage, of both ROM and RAM, depends heavily on application usage. How many (and which) interface functions are referenced determines the code and constant data space requirements. The greater the quantity of file system objects (buffers, files, directories, devices and volumes), the more RAM needed.

Table 2-1 give the ROM usage for the file system core, plus additional components that can be included optionally, collected on IAR EWARM v6.40.1. The 'core' ROM size includes *all* file system components and functions (except those itemized in the table); this is significantly larger than most installations because most applications use a fraction of the API.

Component	ROM, Thumb Mode		ROM, ARM Mode	
	High Size Opt	High Speed Opt	High Size Opt	High Speed Opt
Core*	43.1 kB	59.2 kB	66.5 kB	91.2 kB
OS port (μ C/OS-III)	1.1 kB	1.4 kB	1.8 kB	2.2 kB
LFN support	4.3 kB	5.2 kB	6.9 kB	8.2 kB
Directories	1.7 kB	2.1 kB	2.7 kB	3.3 kB
Volume check	0.9 kB	1.0 kB	1.4 kB	1.6 kB
Partitions	1.3 kB	1.8 kB	2.2 kB	2.9 kB

Table 4-1 ROM requirements

*Includes code and data for *all* file system components and functions except those itemized in the table.

RAM requirements are summarized in Table 2-2. The total depends on the number of each object allocated and the maximum sector size (set by values passed to `FS_Init()` in the file system configuration structure), and various name length configuration parameters (see Appendix E, “FS_CFG_MAX_PATH_NAME_LEN” on page 503).

Item	RAM (bytes)
Core	932
Per device	44 + FS_CFG_MAX_DEV_NAME_LEN
Per volume	152 + FS_CFG_MAX_VOL_NAME_LEN
Per file	144
Per directory	100
Per buffer	36 + MaxSectorSize
Per device driver	8 bytes
Working directories	$((FS_CFG_MAX_PATH_NAME_LEN * 2) + 8) * TaskCnt$

Table 4-2 **RAM characteristics**

§ The number of tasks that use relative path names

See also section 9-1-1 “Driver Characterization” on page 113 for ROM/RAM characteristics of file system suite drivers.

Devices and Volumes

To begin reading files from a medium or creating files on a medium, that medium (hereafter called a device) and the driver which will be used to access it must be registered with the file system. After that, a volume must be opened on that device (analogous to “mounting”). This operation will succeed if and only if the device responds and the file system control structures (for FAT, the Boot Parameter Block or BPB) are located and validated.

In this manual, as in the design of $\mu\text{C}/\text{FS}$, the terms ‘device’ and ‘volume’ have distinct, non-overlapping meanings. We define a ‘device’ as *a single physical or logical entity which contains a continuous sequence of addressable sectors*. An SD/MMC card is a physical device.

We define a ‘volume’ as *a collection of files and directories on a device*.

These definitions were selected so that multiple volumes could be opened on a device (as shown in Figure 5-1) without requiring ambiguous terminology.

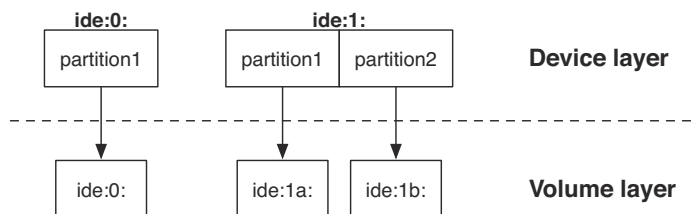

Figure 5-1 **Device and volume architecture**

5-1 DEVICE OPERATIONS

The ultimate purpose of a file system device is to hold data. Consequently, two major operations that can occur on a device are the reading and writing of individual sectors. Five additional operations can be performed which affect not just individual sectors, but the whole device:

- A device can be **opened**. During the opening of a device, it is initialized and its characteristics are determined (sector size, number of sectors, vendor).
- A device can be **partitioned**. Partitioning divides the final unallocated portion of the device into two parts, so that a volume could be located on each (see section 5-5 “Partitions” on page 73).
- A device can be **low-level formatted**. Some device must be low-level formatted before being used.
- A device can be **(high-level) formatted**. (High-level) formatting writes the control information for a file system to a device so that a volume on it can be mounted. Essentially, (high-level) formatting is the process of creating a volume on an empty device or partition.
- A device can be **closed**. During the closing of a device, it is uninitialized (if necessary) and associated structures are freed.

These operations and the corresponding API functions are discussed in this section. For information about using device names, see section 4-2 “ μ C/FS Device and Volume Names” on page 61.

Function	Description
FSDev_AccessLock()	Acquire exclusive access to a device.
FSDev_AccessUnlock()	Release exclusive access to a device.
FSDev_Close()	Remove device from file system.
FSDev_GetNbrPartitions()	Get number of partitions on a device.
FSDev_Invaliddate()	Invalidate files and volumes open on a device.
FSDev_IO_Ctrl()	Perform device I/O control operation.

Function	Description
FSDev_Open()	Add device to file system.
FSDev_PartitionAdd()	Add partition to device.
FSDev_PartitionFind()	Find partition on device and get information about partition.
FSDev_PartitionInit()	Initialize partition on device.
FSDev_Query()	Get device information.
FSDev_Rd()	Read sector on device.
FSDev_Refresh()	Refresh device in file system.
FSDev_Wr()	Write sector on device.

Table 5-1 Device API functions

5-2 USING DEVICES

A device is opened with `FSDev_Open()`:

```

FSDev_Open((CPU_CHAR *)"ide:0:",    <-- (a) device name
           (void *) 0,              <-- (b) pointer to configuration
           (FS_ERR *)&err);        <-- (c) return error

```

The parameters are the device name (a) and a pointer to a device driver-specific configuration structure (b). If a device driver requires no configuration structure (as the SD driver does not), the configuration structure (b) should be passed a `NULL` pointer. For other devices, like RAM disks, this *must* point to a valid structure.

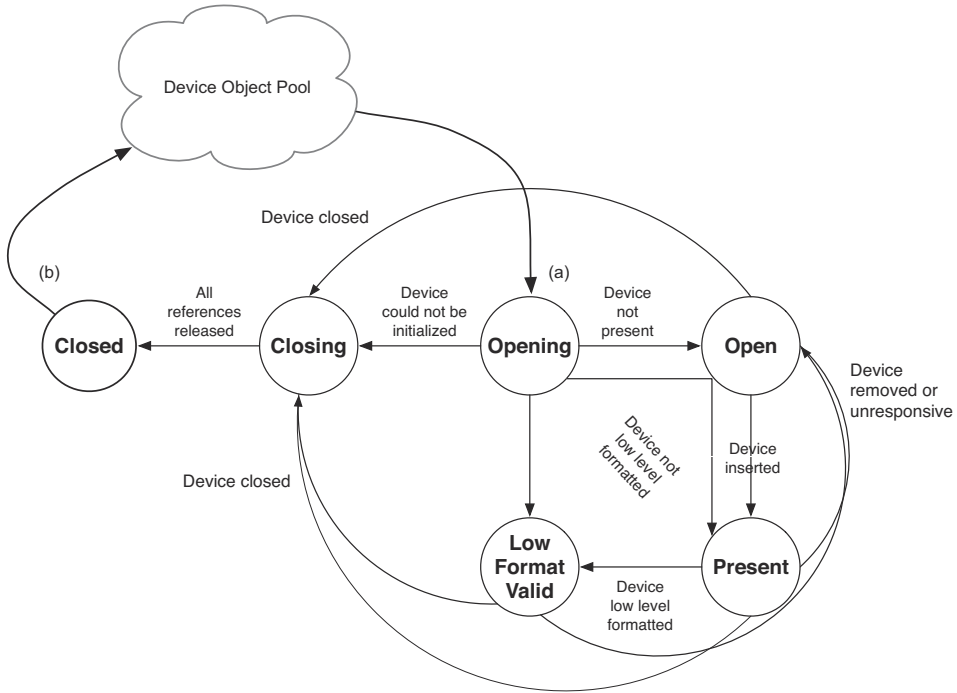

Figure 5-2 **Device state transition**

Prior to `FSDev_Open()` being called (a), software is ignorant of the presence, state or characteristics of the particular device. After all references to the device are released (b), this ignorance again prevails, and any buffers or structures are freed for later use.

The return error code from this functions provides important information about the device state:

- If the return error code is `FS_ERR_NONE`, then the device is present, responsive and low-level formatted; basically, it is ready to use.
- If the return error code is `FS_ERR_DEV_INVALID_LOW_FMT`, then the device is present and responsive, but must be low-level formatted. The application should next call `FSDev_NOR_LowFmt()` for the NOR flash

- If the return error code is `FS_ERR_DEV_NOT_PRESENT`, `FS_ERR_DEV_IO` or `FS_ERR_DEV_TIMEOUT`, the device is either not present or did not respond. This is an important consideration for removable devices. It is still registered with the file system suite, and the file system will attempt to re-open the device each time the application accesses it.
- If any other error code is returned, the device is *not* registered with the file system. The developer should examine the error code to determine the source of the error.

5-3 USING REMOVABLE DEVICES

μ C/FS expects that any call to a function that accesses a removable device may fail, since the device may be removed, powered off or suddenly unresponsive. If μ C/FS detects such an event, the device will need to be refreshed or closed and re-opened. `FSDev_Refresh()` refreshes a device:

```

chngd = FSDev_Refresh((CPU_CHAR *)"ide:0:", <-- (b) device name
                    (FS_ERR *)&err); <-- (c) return error

```

There are several cases to consider:

- If the return error is `FS_ERR_NONE` and the return value (a) is `DEF_YES`, then a new device (e.g., SD card) has been inserted. All files and directories that are open on volumes on the device must be closed and all volumes that are open on the device must be closed or refreshed.
- If the return error is `FS_ERR_NONE` and the return value (a) is `DEF_NO`, then the same device (e.g., SD card) is still inserted. The application can continue to access open files, directories and volumes.
- If the return error is neither `FS_ERR_NONE` nor `FS_ERR_DEV_INVALID_LOW_FMT`, then no functioning device is present. The device must be refreshed at a later time.

A device can be refreshed explicitly with `FSDev_Refresh()`; however, refresh also happens automatically. If a volume access (e.g., `FSVol_Fmt()`, `FSVol_Rd()`), entry access (`FSEntry_Create()`, `fs_remove()`), file open (`fs_fopen()` or `FSFile_Open()`) or

directory open (`fs_opendir()` or `FSDir_Open()`) is initiated on a device that was not present at the last attempted access, μ C/FS attempts to refresh the device information; if that succeeds, it attempts to refresh the volume information.

Files and directories have additional behavior. If a file is opened on a volume, and the underlying device is subsequently removed or changed, all further accesses using the file API (e.g., `FSFile_Rd()`) will fail with the error code `FS_ERR_DEV_CHNGD`; all POSIX API functions will return error values. The file should then be closed (to free the file structure).

Similarly, if a directory is opened on a volume, and the underlying device is subsequently removed or changed, all further `FSDir_Rd()` attempts will fail with the error code `FS_ERR_DEV_CHNGD`; `fs_readdir_r()` will return 1. The directory should then be closed (to free the directory structure).

5-4 RAW DEVICE IO

Opened devices can be accessed directly at the sector level, completely bypassing the file system. Such read and write operations on raw devices are accomplished by using `FSDev_Rd()` and `FSDev_Wr()` to respectively read and write one or more sector at a time. However, doing so may have the unwanted side-effect of corrupting an existing file system on the device and as such, should be done carefully.

Applications wishing to use both the high level file system API of μ C/FS and raw device access concurrently may acquire a global lock to a device with `FSDev_AccessLock()`. While the application has ownership of a device's access lock all higher level operations such as the `FSFile_` and `FSEntry_` type of functions will wait for the lock to be released. The lock can then be released using `FSDev_AccessUnlock()` to give back access to the device.

When raw device operations are used to make changes on opened files and volumes it is generally required to invalidate them to prevent μ C/FS from performing inconsistent operations on the file system. A call to `FSDev_Invalidate()` will make every operations on files and volumes opened on a device fail with an `FS_ERR_DEV_CHNGD` error. Affected files and volumes will then have to be closed and re-opened to continue, similarly to a removable media change.

5-5 PARTITIONS

A device can be partitioned into two or more regions, and a file system created on one or more of these, each of which could be mounted as a volume. $\mu\text{C}/\text{FS}$ can handle and make DOS-style partitions, which is a common partitioning system.

The first sector on a device with DOS-style partitions is the Master Boot Record (MBR), with a partition table with four entries, each describing a partition. An MBR entry contains the start address of a partition, the number of sectors it contains and its type. The structure of a MBR entry and the MBR sector is shown in Figure 5-4.

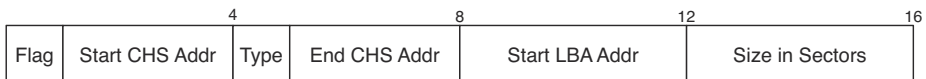

Figure 5-3 Partition entry format

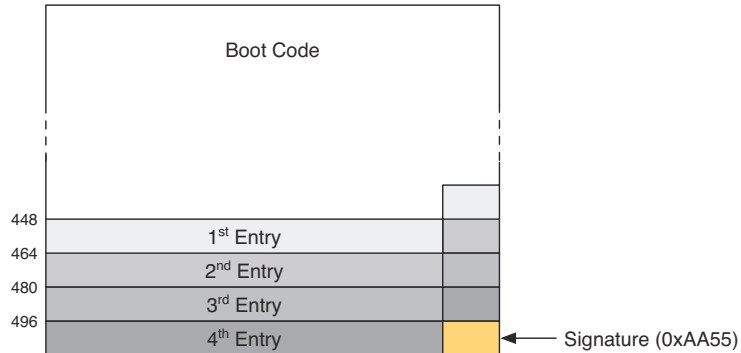

Figure 5-4 Master boot record

An application can write an MBR to a device and create an initial partition with `FSDev_PartitionInit()`. For example, if you wanted to create an initial 256-MB partition on a 1-GB device “`ide:0:`”:

```
FSDev_PartitionInit((CPU_CHAR *)"ide:0:",      <-- (a) device name
                    (FS_SEC_QTY ) (512 * 1024), <-- (b) size of partition
                    (FS_ERR   *)&err);        <-- (c) return error
```

The parameters are the device name (a) and the size of the partition, in sectors (b). If (b) is 0, then the partition will take up the entire device. After this call, the device will be divided as shown in Figure 5-5. This new partition is called a **primary partition** because its entry is in the MBR. The four circles in the MBR represent the four partition entries; the one that is now used 'points to' Primary Partition 1.

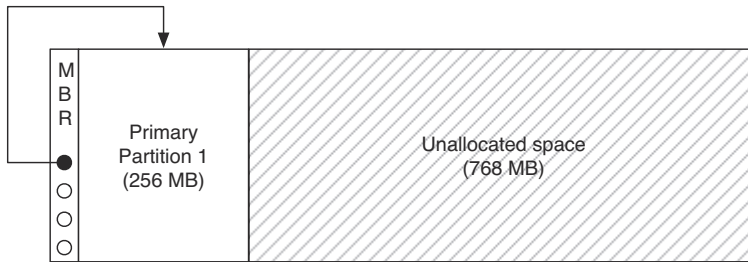

Figure 5-5 Device after partition initialization

More partitions can now be created on the device. Since the MBR has four partition entries, three more can be made without using extended partitions (as discussed below). The function `FSDev_PartitionAdd()` should be called three times:

```

FSDev_PartitionAdd((CPU_CHAR *)"ide:0:",    <-- (a) device name
                   (FS_SEC_QTY )(512 * 1024), <-- (b) size of partition
                   (FS_ERR  *)&err);        <-- (c) return error
    
```

Again, the parameters are the device name (a) and the size of the partition, in sectors (b). After this has been done, the device is divided as shown in Figure 5-6.

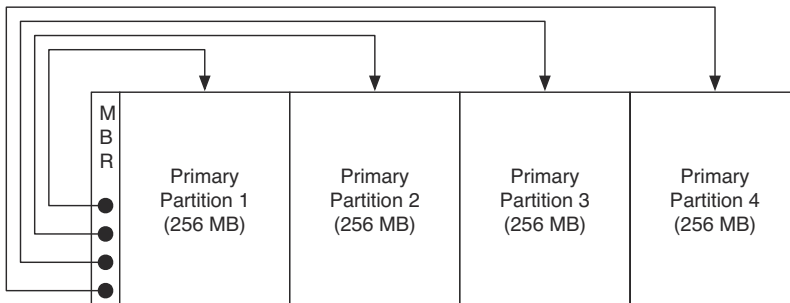

Figure 5-6 Device after four partitions have been created

When first instituted, DOS partitioning was a simple scheme allowing up to four partitions, each with an entry in the MBR. It was later extended for larger devices requiring more with **extended partitions**, partitions that contains other partitions. The **primary extended partition** is the extended partition with its entry in the MBR; it should be the last occupied entry.

An extended partition begins with a partition table that has up to two entries (typically). The first defines a **secondary partition** which may contain a file system. The second may define another extended partition; in this case, a **secondary extended partition**, which can contain yet another secondary partition and secondary extended partition. Basically, the primary extended partition heads a linked list of partitions.

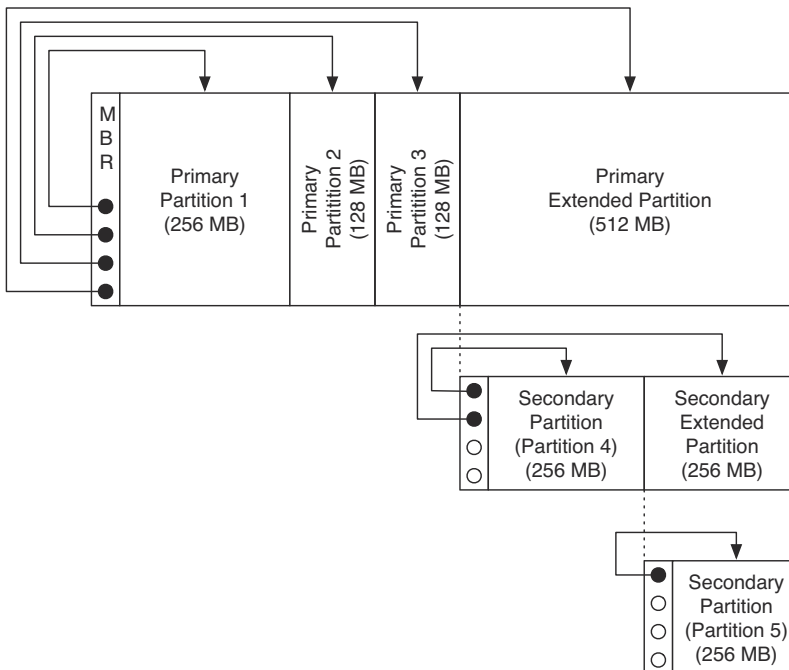

Figure 5-7 Device with five partitions

For the moment, extended partitions are not supported in $\mu\text{C}/\text{FS}$.

5-6 VOLUME OPERATIONS

Five general operations can be performed on a volume:

- A volume can be **opened (mounted)**. During the opening of a volume, file system control structures are read from the underlying device, parsed and verified.
- **Files can be accessed** on a volume. A file is a linear data sequence ('file contents') associated with some logical, typically human-readable identifier ('file name'). Additional properties, such as size, update date/time and access mode (e.g., read-only, write-only, read-write) may be associated with a file. File accesses constitute reading data from files, writing data to files, creating new files, renaming files, copying files, etc. File access is accomplished via file module-level functions, which are covered in Chapter 6, "Files" on page 83.
- **Directories can be accessed** on a volume. A directory is a container for files and other directories. Operations include iterating through the contents of the directory, creating new directories, renaming directories, etc. Directory access is accomplished via directory module-level functions, which are covered in Chapter 7, "Directories" on page 93.
- A volume can be **formatted**. (More specifically, high-level formatted.) Formatting writes the control information for a file system to the partition on which a volume is located.
- A volume can be **closed (unmounted)**. During the closing of a volume, any cached data is written to the underlying device and associated structures are freed.

For information about using volume names, see section 4-2 "µC/FS Device and Volume Names" on page 61. For FAT-specific volume functions, see Chapter 4, "File Systems: FAT" on page 153.

Function	Description	Valid for Unmounted Volume?
FSVol_CacheAssign()	Assign cache to volume.	Yes
FSVol_CacheInvalidate()	Invalidate cache for volume.	No
FSVol_CacheFlush()	Flush cache for volume.	No
FSVol_Close()	Close (unmount) volume.	Yes
FSVol_Fmt()	Format volume.	Yes
FSVol_IsMounted()	Determine whether volume is mounted.	Yes
FSVol_LabelGet()	Get volume label.	No
FSVol_LabelSet()	Set volume label.	No
FSVol_Open()	Open (mount) volume.	----
FSVol_Query()	Get volume information.	Yes
FSVol_Rd()	Read sector on volume.	No
FSVol_Refresh()	Refresh a volume.	No
FSVol_Wr()	Write sector on volume.	No

Table 5-2 Volume API functions

5-7 USING VOLUMES

A volume is opened with `FSVol_Open()`:

```

FSVol_Open((CPU_CHAR      *)"ide:0:", <-- (a) volume name
           (CPU_CHAR      *)"ide:0:", <-- (b) device name
           (FS_PARTITION_NBR *) 0,    <-- (c) partition number
           (FS_ERR        *)&err);  <-- (d) return error

```

Listing 5-1 `FSVol_Open()`

The parameters are the volume name (a), the device name (b) and the partition that will be opened (c). There is no restriction on the volume name (a); however, it is typical to give the volume the same name as the underlying device. If the default partition is to be opened, or if the device is not partitioned, then the partition number (c) should be zero.

The return error code from this function provides important information about the volume state:

- If the return error code is `FS_ERR_NONE`, then the volume has been mounted and is ready to use.
- If the return error code is `FS_ERR_PARTITION_NOT_FOUND`, then no valid file system could be found on the device, or the specified partition does not exist. The device may need to be formatted (see below).
- If the return error code is `FS_ERR_DEV`, `FS_ERR_DEV_NOT_PRESENT`, `FS_ERR_DEV_IO` or `FS_ERR_DEV_TIMEOUT`, the device is either not present or did not respond. This is an important consideration for removable devices. The volume is still registered with the file system suite, and the file system will attempt to re-open the volume each time the application accesses it (see section 5-2 “Using Devices” on page 69 for more information).
- If any other error code is returned, the volume is *not* registered with the file system. The developer should examine the error code to determine the source of the error.

`FSVol_Fmt()` formats a device, (re-)initializing the file system on the device:

```
FSVol_Fmt((CPU_CHAR *)"ide:0:", <-- (a) volume name
          (void      *) 0,      <-- (b) pointer to system configuration
          (FS_ERR   *)&err);  <-- (c) return error
```

The parameters are the volume name (a) and a pointer to file system-specific configuration (b). The configuration is not required; if you are willing to accept the default format, a NULL pointer should be passed. Alternatively, the exact properties of the file system can be configured by passing a pointer to a `FS_FAT_SYS_CFG` structure as the second argument. For more information about the `FS_FAT_SYS_CFG` structure, see section D-7 “FS_FAT_SYS_CFG” on page 492.

5-8 USING VOLUME CACHE

File accesses often incur repeated reading of the same volume sectors. On a FAT volume, these may be sectors in the root directory, the area of the file allocation table (FAT) from which clusters are being allocated or data from important (often-read) files. A cache wedged between the system driver and volume layers (as shown in Figure 5-8) will eliminate many unnecessary device accesses. Sector data is stored upon first read or write. Further reads return the cached data; further writes update the cache entry and, possibly, the data on the volume (depending on the cache mode).

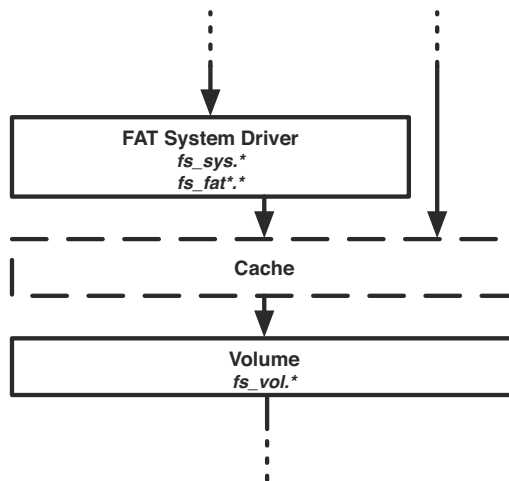

Figure 5-8 Volume cache architecture

A cache is defined by three parameters: size, sector type allocation and mode. The size of the cache is the number of sectors that will fit into it at any time. Every sector is classified according to its type, either management, directory or file; the **sector type allocation** determines the percentage of the cache that will be devoted to each type. The **mode** determines when cache entries are created (i.e., when sectors are cached) and what happens upon write.

Cache Mode	Description	Cache Mode #define
Read cache	Sectors cached upon read; never cached upon write.	FS_VOL_CACHE_MODE_RD
Write-through cache	Sectors cached upon read and write; data on volume always updated upon write.	FS_VOL_CACHE_MODE_WR_THROUGH
Write-back cache	Sectors cached upon read and write; data on volume never updated upon write.	FS_VOL_CACHE_MODE_WR_BACK

Table 5-3 **Cache types**

5-8-1 CHOOSING CACHE PARAMETERS

The following is an example using the cache for the volume “sdcard:0:”. The cache is used in write back mode, and the cache parameters are:

25% of cache size is used for management sector, 15% is used for directories sectors and the remaining (60%) is used for file sectors.

```

FSVol_CacheAssign ((CPU_CHAR      *)"sdcard:0:",          <-- volume name
                  (FS_VOL_CACHE_API *) NULL,            <-- pointer to vol cache API
                  (void             *)&CACHE_BUF[0],     <-- pointer to the cache buf
                  (CPU_INT32U       ) CACHE_BUF_LEN,     <-- cache buf size in bytes
                  (CPU_INT08U       ) 25,                <-- see (1)
                  (CPU_INT08U       ) 15,                <-- see (2)
                  (FS_FLAGS          ) FS_VOL_CACHE_MODE_WR_BACK, <-- cache mode
                  (FS_ERR            *)&err);            <-- used for error code

if (err != FS_ERR_NONE) {
    APP_TRACE_INFO (" Error : could not assign Volume cache");
    return;
}

pfile = FSFile_Open("sdcard:0:\\file.txt",
                   FS_FILE_ACCESS_MODE_WR |
                   FS_FILE_ACCESS_MODE_CACHED,
                   &err);
if (pFile == (FS_FILE *)0) {
    return;
}

/*
   DO THE WRITE OPERATIONS TO THE FILE
*/

FSFile_Close (pFile, &err);

FSVol_CacheFlush ("sdcard:0:", &err);                <-- Flush volume cache.

```

Listing 5-2 Cache

L5-2(1) Percent of cache buffer dedicated to management sectors.

L5-2(2) Percent of cache buffer dedicated to directory sectors.

The application using μ C/FS volume cache should vary the third and fourth parameters passed to `FSVol_CacheAssign()`, and select the values that give the best performance.

For an efficient cache usage, it is better to do not allocate space in the cache for sectors of type file when the write size is greater than sector size.

When the cache is used in write back mode, all cache dirty sectors will be updated on the media storage only when the cache is flushed.

5-8-2 OTHER CACHING AND BUFFERING MECHANISMS

Volume cache is just one of several important caching mechanisms, which should be balanced for optimal performance within the bounds of platform resources. The second important software mechanism is the file buffer (see section 6-1-3 “Configuring a File Buffer” on page 87), which makes file accesses more efficient by buffering data so a full sector’s worth will be read or written.

Individual devices or drivers may also integrate a cache. Standard hard drives overcome long seek times by buffering extra data upon read (in anticipation of future requests) or clumping writes to eliminate unnecessary movement. The latter action can be particularly powerful, but since it may involve re-ordering the sequence of sector writes will eliminate any guarantee of fail-safety of most file systems. For that reason, write cache in most storage devices should be disabled.

A driver may implement a buffer to reduce apparent write latency. Before a write can occur to a flash medium, the driver must find a free (erased) area of a block; occasionally, a block will need to be erased to make room for the next write. Incoming data can be buffered while the long erase occurs in the background, thereby uncoupling the application’s wait time from the real maximum flash write time.

The ideal system might use both volume cache and file buffers. A volume cache is most powerful when confined to the sector types most subject to repeated reads: management and directory. Caching of files, if enabled, should be limited to important (often-read) files. File buffers are more flexible, since they cater to the many applications that find small reads and writes more convenient than those of full sectors.

An application stores information in a file system by creating a file or appending new information to an existing file. At a later time, this information may be retrieved by reading the file. Other functions support these capabilities; for example, the application can move to a specified location in the file or query the file system to get information about the file. These functions, which operate on file structures (**FS_FILES**), are grouped under file access (or simply file) functions. The available file functions are listed in Table 6-1.

A separate set of file operations (or entry) functions manage the files and directories available on the system. Using these functions, the application can copy, create, delete and rename files, and get and set a file or directory's attributes and date/time. The available entry functions are listed in Table 6-3.

The entry functions and the **FSFile_Open()** function accept full file paths. For information about using file and path names, see section 4-3 “ μ C/FS File and Directory Names and Paths” on page 62.

The functions listed in Table 6-1 and Table 6-3 are core functions in the file access module (**FSFile_####()** functions) and entry module (**FSEntry_####()** functions). These are matched, in most cases, by API level functions that correspond to standard C or POSIX functions. The core and API functions provide basically the same functionality; the benefits of the former are enhanced capabilities, a consistent interface and meaningful return error codes.

6-1 FILE ACCESS FUNCTIONS

The file access functions provide an API for performing a sequence of operations on a file located on a volume's file system. The file object pointer returned when a file is opened is passed as the first argument of all file access functions (a characteristic which distinguishes these from the entry access functions), and the file object so referenced maintains information about the actual file (on the volume) and the state of the file access. The file access state includes the file position (the next place data will be read/written), error conditions and (if file buffering is enabled) the state of any file buffer.

Function	Description
FSFile_BufAssign()	Assign buffer to a file.
FSFile_BufFlush()	Write buffered data to volume.
FSFile_Close()	Close a file.
FSFile_ClrErr()	Clear error(s) on a file.
FSFile_IsEOF()	Determine whether a file is at EOF.
FSFile_IsErr()	Determine whether error occurred on a file.
FSFile_IsOpen()	Determine whether a file is open or not.
FSFile_LockGet()	Acquire task ownership of a file.
FSFile_LockSet()	Release task ownership of a file.
FSFile_LockAccept()	Acquire task ownership of a file (if available).
FSFile_Open()	Open a file.
FSFile_PosGet()	Get file position.
FSFile_PosSet()	Set file position.
FSFile_Query()	Get information about a file.
FSFile_Rd()	Read from a file.
FSFile_Truncate()	Truncate a file.
FSFile_Wr()	Write to a file.

Table 6-1 File access functions

6-1-1 OPENING FILES

When an application needs to access a file, it must first open it using `fs_fopen()` or `FSFile_Open()`. For most applications, the former with its familiar interface suffices. In some cases, the flexibility of the latter is demanded:

```
file ptr --> p_file = FSFile_Open ("\\file.txt",          <-- file name
                                   FS_FILE_ACCESS_MODE_RD, <-- access mode
                                   &err);                <-- return error

if (p_file == (FS_FILE *)0) {
    /* $$$ Handle error */
}
```

The return value of this function should always be verified as non-NULL before the application proceeds to access the file. The second argument to this function is a logical OR of mode flags:

<code>FS_FILE_ACCESS_MODE_RD</code>	File opened for reads.
<code>FS_FILE_ACCESS_MODE_WR</code>	File opened for writes.
<code>FS_FILE_ACCESS_MODE_CREATE</code>	File will be created, if necessary.
<code>FS_FILE_ACCESS_MODE_TRUNC</code>	File length will be truncated to 0.
<code>FS_FILE_ACCESS_MODE_APPEND</code>	All writes will be performed at EOF.
<code>FS_FILE_ACCESS_MODE_EXCL</code>	File will be opened if and only if it does not already exist.
<code>FS_FILE_ACCESS_MODE_CACHED</code>	File data will be cached.

For example, if you wanted to create a file to write to if and only if it does not exist, you would use the flags

```
FS_FILE_ACCESS_MODE_WR | FS_FILE_ACCESS_MODE_CREATE | FS_FILE_ACCESS_MODE_EXCL
```

It is impossible to do this in a single, atomic operation using `fs_fopen()`.

The table below lists the mode flag equivalents of the `fs_fopen()` mode strings.

"r" or "rb"	FS_FILE_ACCESS_MODE_RD
"w" or "wb"	FS_FILE_ACCESS_MODE_WR FS_FILE_ACCESS_MODE_CREATE FS_FILE_ACCESS_MODE_TRUNC
"a" or "ab"	FS_FILE_ACCESS_MODE_WR FS_FILE_ACCESS_MODE_CREATE FS_FILE_ACCESS_MODE_APPEND
"r+" or "rb+" or "r+b"	FS_FILE_ACCESS_MODE_RD FS_FILE_ACCESS_MODE_WR
"w+" or "wb+" or "w+b"	FS_FILE_ACCESS_MODE_RD FS_FILE_ACCESS_MODE_WR FS_FILE_ACCESS_MODE_CREATE FS_FILE_ACCESS_MODE_TRUNC
"a+" or "ab+" or "a+b"	FS_FILE_ACCESS_MODE_RD FS_FILE_ACCESS_MODE_WR FS_FILE_ACCESS_MODE_CREATE FS_FILE_ACCESS_MODE_APPEND

Table 6-2 `fopen()` mode strings and mode equivalents

6-1-2 GETTING INFORMATION ABOUT A FILE

Detailed information about an open file, such as size and date/time stamps, can be obtained using the `FSFile_Query()` function:

```
FS_ENTRY_INFO info;
FSFile_Query(p_file, <-- file pointer
              &info, <-- pointer to info structure
              &err); <-- return error
```

The `FS_ENTRY_INFO` structure has the following members:

- **Attrib** contains the file attributes (see section 6-2-1 “File and Directory Attributes” on page 90).
- **Size** is the size of the file, in octets.

- `DateTimeCreate` is the creation timestamp of the file.
- `DateAccess` is the access timestamp (date only) of the file.
- `DateTimeWr` is the last write (or modification) timestamp of the file.
- `BlkCnt` is the number of blocks allocated to the file. For a FAT file system, this is the number of clusters occupied by the file data.
- `BlkSize` is the size of each block allocated in octets. For a FAT file system, this is the size of a cluster.

`DateTimeCreate`, `DateAccess` and `DateTimeWr` are structures of type `CLK_TS_SEC`.

6-1-3 CONFIGURING A FILE BUFFER

The file module has functions to assign and flush a file buffer that are equivalents to POSIX API functions; the primary difference is the advantage of valuable return error codes to the application.

File Module Function	POSIX API Equivalent
<pre>void FSFile_BufAssign (FS_FILE *p_file, void *p_buf, FS_FLAGS mode, CPU_SIZE_T size, FS_ERR *p_err);</pre>	<pre>int fs_setvbuf (FS_FILE *stream, char *buf, int mode, fs_size_t size);</pre>
<pre>void FSFile_BufFlush (FS_FILE *p_file, FS_ERR *p_err);</pre>	<pre>int fs_fflush (FS_FILE *stream);</pre>

For more information about and an example of configuring a file buffer, see section 8-3-3 “Configuring a File Buffer” on page 104.

6-1-4 FILE ERROR FUNCTIONS

The file module has functions get and clear a file's error status that are almost exact equivalents to POSIX API functions; the primary difference is the advantage of valuable return error codes to the application.

File Module Function	POSIX API Equivalent
void FSFile_ClrErr (FS_FILE *p_file, FS_ERR *p_err);	void fs_clearerr (FS_FILE *stream);
CPU_BOOLEAN FSFile_IsErr (FS_FILE *p_file, FS_ERR *p_err);	int fs_ferror (FS_FILE *stream);
CPU_BOOLEAN FSFile_IsEOF (FS_FILE *p_file, FS_ERR *p_err);	int fs_feof (FS_FILE *stream);

For more information about this functionality, see section 8-3-4 “Diagnosing a File Error” on page 106.

6-1-5 ATOMIC FILE OPERATIONS USING FILE LOCK

The file module has functions lock files across several operations that are almost exact equivalents to POSIX API functions; the primary difference is the advantage of valuable return error codes to the application.

File Module Function	POSIX API Equivalent
void FSFile_LockGet (FS_FILE *p_file, FS_ERR *p_err);	void fs_flockfile (FS_FILE *file);
void FSFile_LockAccept (FS_FILE *p_file, FS_ERR *p_err);	int fs_ftrylockfile (FS_FILE *file);
void FSFile_LockSet (FS_FILE *p_file, FS_ERR *p_err);	void fs_funlockfile (FS_FILE *file);

For more information about and an example of using file locking, see section 8-3-5 “Atomic File Operations Using File Lock” on page 106.

6-2 ENTRY ACCESS FUNCTIONS

The entry access functions provide an API for performing single operations on file system entries (files and directories), such as copying, renaming or deleting. Each of these operations is atomic; consequently, in the absence of device access errors, either the operation will have completed or no change to the storage device will have been made upon function return.

One of these functions, `FSEntry_Query()`, obtains information about an entry (including the attributes, date/time stamp and file size). Two functions set entry properties, `FSEntry_AttribSet()` and `FSEntry_TimeSet()`, which set a file's attributes and date/time stamp. A new file entry can be created with `FSEntry_Create()` or an existing entry deleted, copied or renamed (with `FSEntry_Del()`, `FSEntry_Copy()` or `FSEntry_Rename()`).

Function	Description
<code>FSEntry_AttribSet()</code>	Set a file or directory's attributes.
<code>FSEntry_Copy()</code>	Copy a file.
<code>FSEntry_Create()</code>	Create a file or directory.
<code>FSEntry_Del()</code>	Delete a file or directory.
<code>FSEntry_Query()</code>	Get information about a file or directory.
<code>FSEntry_Rename()</code>	Rename a file or directory.
<code>FSEntry_TimeSet()</code>	Set a file or directory's date/time.

Table 6-3 Entry API functions

6-2-1 FILE AND DIRECTORY ATTRIBUTES

The `FSEntry_Query()` function gets information about file system entry, including its attributes, which indicate whether it is a file or directory, writable or read-only, and visible or hidden:

```
FS_FLAGS      attrib;
FS_ENTRY_INFO info;
FSEntry_Query("path_name", <-- pointer to full path name
              &info,      <-- pointer to info
              &err);     <-- return error
attrib = info.Attrib;
```

The return value is a logical OR of attribute flags:

<code>FS_ENTRY_ATTRIB_RD</code>	Entry is readable.
<code>FS_ENTRY_ATTRIB_WR</code>	Entry is writable.
<code>FS_ENTRY_ATTRIB_HIDDEN</code>	Entry is hidden from user-level processes.
<code>FS_ENTRY_ATTRIB_DIR</code>	Entry is a directory.
<code>FS_ENTRY_ATTRIB_ROOT_DIR</code>	Entry is a root directory.

If no error is returned and `FS_ENTRY_ATTRIB_DIR` is not set, then the entry is a file.

An entry can be made read-only (or writable) or hidden (or visible) by setting its attributes:

The second argument should be the logical OR of relevant attribute flags.

```
attrib = FS_ENTRY_ATTRIB_RD;
FSEntry_AttribSet("path_name", <-- pointer to full path name
                  attrib,      <-- attributes
                  &err);      <-- return error
```

FS_ENTRY_ATTRIB_RD Entry is readable.

FS_ENTRY_ATTRIB_WR Entry is writable.

FS_ENTRY_ATTRIB_HIDDEN Entry is hidden from user-level processes.

If a flag is clear (not OR'd in), then that attribute will be clear. In the example above, the entry will be made read-only (i.e., not writable) and will be visible (i.e., not hidden) since the WR and HIDDEN flags are not set in `attrib`. Since there is no way to make files write-only (i.e., not readable), the RD flag should always be set.

6-2-2 CREATING NEW FILES AND DIRECTORIES

A new file can be created using `FSfile_Open()` or `fs_fopen()`, if opened in write or append mode. There are a few other ways that new files can be created (most of which also apply to new directories).

The simplest is the `FSEntry_Create()` function, which just makes a new file or directory:

```
FSEntry_Create("\\file.txt",                <-- file name
              FS_ENTRY_TYPE_FILE,        <-- means entry will be a file
              DEF_NO,                    <-- DEF_NO means creation NOT exclusive
              &err);                    <-- return error
```

If the second argument, `entry_type`, is `FS_ENTRY_TYPE_DIR` the new entry will be a directory. The third argument, `excl`, indicates whether the creation should be exclusive. If it is exclusive (`excl` is `DEF_YES`), nothing will happen if the file already exists. Otherwise, the file currently specified by the file name will be deleted and a new empty file with that name created.

Similar functions exist to copy and rename an entry:

```
FSEntry_Copy("\\dir\\src.txt",      <-- source file name
             "\\dir\\dest.txt »,   <-- destination file name
             DEF_NO,               <-- DEF_NO means creation not exclusive
             &err);               <-- return error
FSEntry_Rename("\\dir\\oldname.txt", <-- old file name
              "\\dir\\newname.txt", <-- new file name
              DEF_NO,             <-- DEF_NO means creation not exclusive
              &err);             <-- return error
```

`FSEntry_Copy()` can only be used to copy files. The first two arguments of each of these are both *full* paths; the second path is not relative to the parent directory of the first. As with `FSEntry_Create()`, the third argument of each, `excl`, indicates whether the creation should be exclusive. If it is exclusive (`excl` is `DEF_YES`), nothing will happen if the destination or new file already exists.

6-2-3 DELETING FILES AND DIRECTORIES

A file or directory can be deleted using `FSEntry_Del()`:

```
FSEntry_Del("\\dir",             <-- entry name
            FS_ENTRY_TYPE_DIR,   <-- means entry must be a dir
            &err);              <-- return error
```

The second argument, `entry_type`, restricts deletion to specific types. If it is `FS_ENTRY_TYPE_DIR`, then the entry specified by the first argument *must* be a directory; if it is a file, an error will be returned. If it is `FS_ENTRY_TYPE_FILE`, then the entry *must* be a file. If it is `FS_ENTRY_TYPE_ANY`, then the entry will be deleted whether it is a file or a directory.

Directories

An application stores information in a file system by creating a file or appending new information to an existing file. At a later time, this information may be retrieved by reading the file. However, if a certain file must be found, or all files may be listed, the application can iterate through the entries in a directory using the **directory access (or simply directory) functions**. The available directory functions are listed in Table 6-1.

A separate set of **directory operations (or entry) functions** manage the files and directories available on the system. Using these functions, the application can create, delete and rename directories, and get and set a directory's attributes and date/time. More information about the entry functions can be found in section 6-2 "Entry Access Functions" on page 89.

The entry functions and the directory `Open()` function accept one or **more full directory** paths. For information about using file and path names, see section 4-3 "µC/FS File and Directory Names and Paths" on page 62.

The functions listed in Table 7-1 are core functions in the directory access module (`FSDir_####()` functions). These are matched by API level functions that correspond to standard C or POSIX functions. More information about the API-level functions can be found in Chapter 8, "POSIX API" on page 95. The core and API functions provide basically the same functionality; the benefits of the former are enhanced capabilities, a consistent interface and meaningful return error codes.

7-1 DIRECTORY ACCESS FUNCTIONS

The directory access functions provide an API for iterating through the entries within a directory. The `FSDir_Open()` function initiates this procedure, and each subsequent call to `FSDir_Rd()` (until all entries have been examined) returns a `FS_DIRENT` which holds information about a particular entry. The `FSDir_Close()` function releases any file system structures and locks.

Function	Description
<code>FSDir_Open()</code>	Open a directory.
<code>FSDir_Close()</code>	Close a directory
<code>FSDir_Rd()</code>	Read a directory entry.
<code>FSDir_IsOpen()</code>	Determine whether a directory is open or not.

Table 7-1 Directory API functions

These functions are almost exact equivalents to POSIX API functions; the primary difference is the advantage of valuable return error codes to the application.

Directory Module Function	POSIX API Equivalent
<code>FS_DIR *FSDir_Open (CPU_CHAR *p_name_full, FS_ERR *p_err);</code>	<code>FS_DIR *fs_opendir (const char *dirname);</code>
<code>void FSDir_Close(FS_DIR *p_dir, FS_ERR *p_err);</code>	<code>int fs_closedir (FS_DIR *dirp);</code>
<code>void FSDir_Rd (FS_DIR *p_dir, FS_DIR_ENTRY *p_dir_entry, FS_ERR *p_err);</code>	<code>int fs_readdir_r (FS_DIR *dirp, struct fs_dirent *entry, struct fs_dirent **result);</code>

For more information about and an example of using directories, see section 8-4 “Directory Access Functions” on page 107.

**Important warning about the POSIX API**

The μ C/FS implementation of the POSIX API is not 100% compliant. Most notably, the `errno` error flag isn't set when an error occurs and thus it is recommended to use the μ C/FS proprietary API (`FSFile_####()`, `FSDir_####()`, `FSEntry_####()`, etc.).

The best-known API for accessing and managing files and directories is specified within the POSIX standard (IEEE Std 1003.1). The basis of some of this functionality, in particular buffered input/output, lies in the ISO C standard (ISO/IEC 9899), though many extensions provide new features and clarify existing behaviors. Functions and macros prototyped in four header files are of particular importance:

- **stdio.h.** Standard buffered input/output (`fopen()`, `fread()`, etc), operating on FILE objects.
- **dirent.h.** Directory accesses (`opendir()`, `readdir()`, etc), operating on DIR objects.
- **unistd.h.** Miscellaneous functions, including working directory management (`chdir()`, `getcwd()`), `ftruncate()` and `rmdir()`.
- **sys/stat.h.** File statistics functions and `mkdir()`.

μ C/FS provides a POSIX-compatible API based on a subset of the functions in these four header files. To avoid conflicts with the user compilation environment, files, functions and objects are renamed:

- All functions begin with 'fs_'. For example, `fopen()` is renamed `fs_fopen()`, `opendir()` is renamed `fs_opendir()`, `getcwd()` is renamed `fs_getcwd()`, etc.

- All objects begin with 'FS_'. So `fs_fopen()` returns a pointer to a `FS_FILE` and `fs_opendir()` returns a pointer to a `FS_DIR`.
- Some argument types are renamed. For example, the second and third parameters of `fs_fread()` are typed `fs_size_t` to avoid conflicting with other `size_t` definitions.

8-1 SUPPORTED FUNCTIONS

The supported POSIX functions are listed in the table below. These are divided into four groups. First, the functions which operate on file objects (`FS_FILES`) are grouped under file access (or simply file) functions. An application stores information in a file system by creating a file or appending new information to an existing file. At a later time, this information may be retrieved by reading the file. Other functions support these capabilities; for example, the application can move to a specified location in the file or query the file system to get information about the file.

A separate set of file operations (or entry) functions manage the files and directories available on the system. Using these functions, the application can create, delete and rename files and directories.

The entries within a directory can be traversed using the directory access (or simply directory) functions, which operate on directory objects (`FS_DIRS`). The name and properties of the entries are returned within a struct `fs_dirent` structure.

The final group of functions is the working directory functions. For information about using file and path names, see section 4-3 “`µC/FS` File and Directory Names and Paths” on page 62.

Function	POSIX Equivalent	Function	POSIX Equivalent
<code>fs_asctime_r()</code>	<code>asctime_r()</code>	<code>fs_ftruncate()</code>	<code>ftruncate()</code>
<code>fs_chdir()</code>	<code>chdir()</code>	<code>fs_ftrylockfile()</code>	<code>ftrylockfile()</code>
<code>fs_clearerr()</code>	<code>clearerr()</code>	<code>fs_funlockfile()</code>	<code>funlockfile()</code>
<code>fs_closedir()</code>	<code>closedir()</code>	<code>fs_fwrite()</code>	<code>fwrite()</code>
<code>fs_ctime_r()</code>	<code>ctime_r()</code>	<code>fs_getcwd()</code>	<code>getcwd()</code>
<code>fs_fclose()</code>	<code>fclose()</code>	<code>fs_localtime_r()</code>	<code>localtime_r()</code>
<code>fs_feof()</code>	<code>feof()</code>	<code>fs_mkdir()</code>	<code>mkdir()</code>

Function	POSIX Equivalent	Function	POSIX Equivalent
fs_ferror()	ferror()	fs_mktime()	mktime()
fs_fflush()	fflush()	fs_rewind()	rewind()
fs_fgetpos()	fgetpos()	fs_opendir()	opendir()
fs_flockfile()	flockfile()	fs_readdir_r()	readdir_r()
fs_fopen()	fopen()	fs_remove()	remove()
fs_fread()	fread()	fs_rename()	rename()
fs_fseek()	fseek()	fs_rmdir()	rmdir()
fs_fsetpos()	fsetpos()	fs_setbuf()	setbuf()
fs_fstat()	fstat()	fs_setvbuf()	setvbuf()
fs_ftell()	ftell()	fs_stat()	stat()

Table 8-1 POSIX API functions

8-2 WORKING DIRECTORY FUNCTIONS

Normally, all file or directory paths must be absolute, either on the default volume or on an explicitly-specified volume:

```
p_file1 = fs_fopen("\\file.txt", "r");           /* File on default volume */
p_file2 = fs_fopen("sdcard:0:\\file.txt", "r"); /* File on explicitly-specified volume */
```

If working directory functionality is enabled, paths may be specified relative to the working directory of the current task:

```
p_file2 = fs_fopen("file.txt", "r");           /* File in working directory */
p_file1 = fs_fopen("../file.txt", "r");       /* File in parent of working directory */
```

The two standard special path components are supported. The path component “..” moves to the parent of the current working directory. The path component “.” makes no change; essentially, it means the current working directory.

`fs_chdir()` is used to set the working directory. If a relative path is employed before any working directory is set, the root directory of the default volume is used.

The application can get the working directory with `fs_getcwd()`. A terminal interface may use this function to implement an equivalent to the standard `pwd` (print working directory) command, while calling `fs_chdir()` to carry out a `cd` operation. If working directories are enabled, the μ C/Shell commands for μ C/FS manipulate and access the working directory with `fs_chdir()` and `fs_getcwd()` (see also Appendix F, “Shell Commands” on page 509).

8-3 FILE ACCESS FUNCTIONS

The file access functions provide an API for performing a sequence of operations on a file located on a volume’s file system. The file object pointer returned when a file is opened is passed as an argument of all file access function, and the file object so referenced maintains information about the actual file (on the volume) and the state of the file access. The file access state includes the file position (the next place data will be read/written), error conditions and (if file buffering is enabled) the state of any file buffer.

As data is read from or written to a file, the file position is incremented by the number of bytes transferred from/to the volume. The file position may also be directly manipulated by the application using the position set function (`fs_fsetpos()`), and the current absolute file position may be gotten with the position get function (`fs_fgetpos()`), to be later used with the position set function.

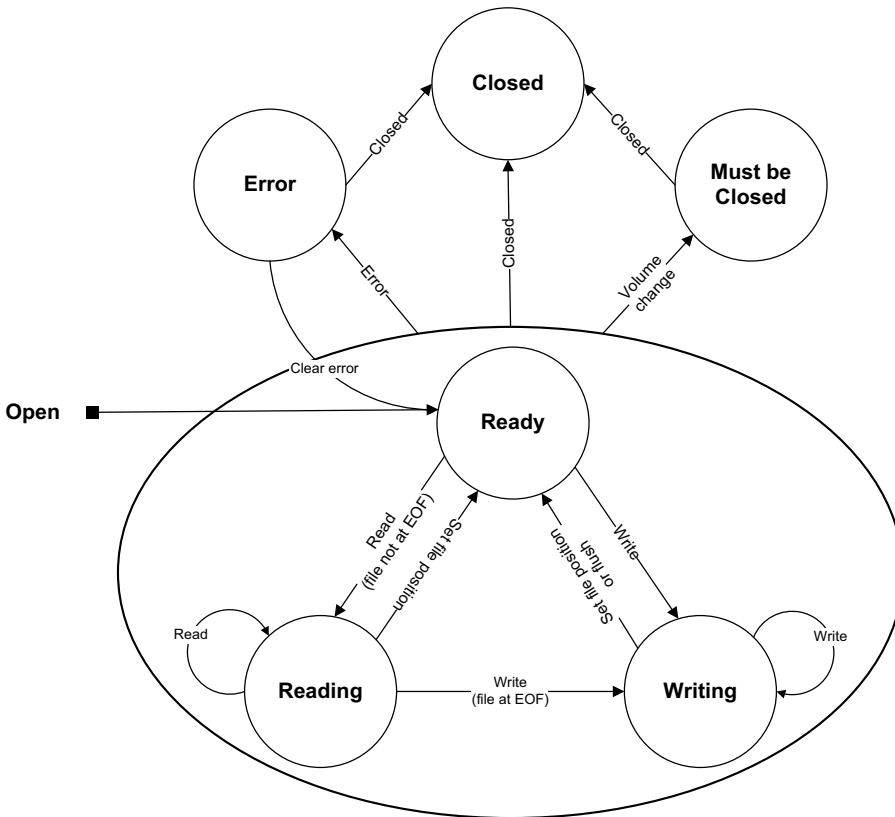

Figure 8-1 File state transitions

The file maintains flags that reflect errors encountered in the previous file access, and subsequent accesses will fail (under certain conditions outlined here) unless these flags are explicitly cleared (using `fs_clearerr()`). There are actually two sets of flags. One reflects whether the file encountered the end-of-file (EOF) during the previous access, and if this is set, writes will not fail, but reads will fail. The other reflects device errors, and no subsequent file access will succeed (except file close) unless this is first cleared. The functions `fs_ferror()` and `fs_feof()` can be used to get the state of device error and EOF conditions, respectively.

If file buffering is enabled (`FS_CFG_FILE_BUF_EN` is `DEF_ENABLED`), then input/output buffering capabilities can be used to increase the efficiency of file reads and writes. A buffer can be assigned to a file using `fs_setbuf()` or `fs_setvbuf()`; the contents of the buffer can be flushed to the storage device using `fs_fflush()`.

If a file is shared between several tasks in an application, a file lock can be employed to guarantee that a series of file operations are executed atomically. `fs_flockfile()` (or its non-blocking equivalent `fs_ftrylockfile()`) acquires the lock for a task (if it does not already own it). Accesses from other tasks will be blocked until a `fs_funlockfile()` is called. This functionality is available if `FS_CFG_FILE_LOCK_EN` is `DEF_ENABLED`.

8-3-1 OPENING, READING AND WRITING FILES

When an application needs to access a file, it must first open it using `fs_fopen()`:

```
file pointer --> p_file = fs_fopen("\\file.txt", <-- file name
                        "w+");          <-- mode string
if (p_file == (FS_FILE *)0) {
    /* $$$ Handle error */
}
```

The return value of this function should always be verified as non-NULL before the application proceeds to access the file. The first argument of this function is the path of the file; if working directories are disabled, this must be the absolute file path, beginning with either a volume name or a ‘\’ (see section 4-3 “μC/FS File and Directory Names and Paths” on page 62). The second argument of this function is a string indicating the mode of the file; this must be one of the strings shown in the table below. Note that in all instances, the ‘b’ (binary) option has no effect on the behavior of file accesses.

fs_fopen() Mode String	Read?	Write?	Truncate?	Create?	Append?
“r” or “rb”	Yes	No	No	No	No
“w” or “wb”	No	Yes	Yes	Yes	No
“a” or “ab”	No	Yes	No	Yes	Yes
“r+” or “rb+” or “r+b”	Yes	Yes	No	No	No
“w+” or “wb+” or “w+b”	Yes	Yes	Yes	Yes	No
“a+” or “ab+” or “a+b”	Yes	Yes	No	Yes	Yes

Table 8-2 `fs_fopen()` mode strings interpretations

After a file is opened, any of the file access functions valid for that its mode can be called. The most commonly used functions are `fs_fread()` and `fs_fwrite()`, which read or write a certain number of 'items' from a file:

```
number of items read --> cnt = fs_fread(p_buf, <-- pointer to buffer
                                1, <-- size of each item
                                100, <-- number of items
                                p_file); <-- pointer to file
```

The return value, the number of items read (or written), should be less than or equal to the third argument. If the operation is a read, this value may be less than the third argument for one of two reasons. First, the file could have encountered the end-of-file (EOF), which means that there is no more data in the file. Second, the device could have been removed, or some other error could have prevented the operation. To diagnose the cause, the `fs_feof()` function should be used. This function returns a non-zero value if the file has encountered the EOF.

Once the file access is complete, the file *must* be closed; if an application fails to close files, then the file system suite resources such as file objects may be depleted.

An example of reading a file is given in Listing 8-1.

```
void App_Funct (void)
{
    FS_FILE      *p_file;
    fs_size_t    cnt;
    unsigned char buf[50];
    .
    .
    .

    p_file = fs_fopen("\\file.txt", "r");          /* Open file.                */

    if (p_file != (FS_FILE *)0) {                /* If file is opened ...        */
                                                /* ... read from file.          */
        do {
            cnt = fs_fread(&buf[0], 1, sizeof(buf), p_file);
            if (cnt > 0) {
                APP_TRACE_INFO(("Read %d bytes.\r\n", cnt));
            }
        } while (cnt >= sizeof(buf));
        eof = fs_feof(p_file);                    /* Chk for EOF.                 */
        if (eof != 0) {                           /* See Note #1.                 */
            APP_TRACE_INFO(("Reached EOF.\r\n"));
        } else {
            err = fs_ferror(p_file);              /* Chk for error.              */
            if (err != 0) {                       /* See Note #2.                */
                APP_TRACE_INFO(("Read error.\r\n"));
            }
        }
        fs_fclose(p_file);                        /* Close file.                  */
    } else {
        APP_TRACE_INFO(("Could not open \\file.txt\r\n"));
    }
    .
    .
    .
}
```

Listing 8-1 Example file read

- L8-1(1) To determine whether a file read terminates because of reaching the EOF or a device error/removal, the EOF condition should be checked using `fs_feof()`.
- L8-1(2) In most situations, either the EOF or the error indicator will be set on the file if the return value of `fs_fread()` is smaller than the buffer size. Consequently, this check is unnecessary.

8-3-2 GETTING OR SETTING THE FILE POSITION

Another common operation is getting or setting the file position. The `fs_fgetpos()` and `fs_fsetpos()` allow the application to ‘store’ a file location, continue reading or writing the file, and then go back to that place at a later time. An example of using file position get and set is given in Listing 8-2.

```
void App_Funct (void)
{
    FS_FILE      *p_file;
    fs_fpos_t    pos;
    int          err;
    .
    .
    .
    p_file = fs_fopen("\\file.txt", "r");          /* Open file ...          */
    if (p_file == (FS_FILE *)0) {
        APP_TRACE_INFO("Could not open file.");
        return;
    }
    .
    .
    .
    err = fs_fgetpos(p_file, &pos);              /* Save file position ...      */
    if (err != 0) {
        APP_TRACE_INFO("Could not get file position.");
        return;
    }
    .
    .
    .
    err = fs_fsetpos(p_file, &pos);              /* Set file to saved position ... */
    if (err != 0) {
        APP_TRACE_INFO("Could not set file position.");
        return;
    }
    .
    .
    .
    FS_fclose(p_file);                            /* When finished, close file.  */
    .
    .
    .
}
```

Listing 8-2 Example file position set/get

8-3-3 CONFIGURING A FILE BUFFER

In order to increase the efficiency of file reads and writes, input/output buffering capabilities are provided. Without an assigned buffer, reads and writes will be immediately performed within `fs_fread()` and `fs_fwrite()`. Once a buffer has been assigned, data will always be read from or written to the buffer; device access will only occur once the file position moves beyond the window represented by the buffer.

`fs_setbuf()` and `fs_setvbuf()` assign the buffer to a file. The contents of the buffer can be flushed to the storage device with `fs_fflush()`. If a buffer is assigned to a file that was opened in update (read/write) mode, then a write may only be followed by a read if the buffer has been flushed (by calling `fs_fflush()` or a file positioning function). A read may be followed by a write only if the buffer has been flushed, except when the read encountered the end-of-file, in which case a write may happen immediately. The buffer is automatically flushed when the file is closed.

File buffering is particularly important when data is written in small chunks to a medium with slow write time or limited endurance. An example is NOR flash, or even NAND flash, where write times are much slower than read times, and the lifetime of device is constrained by limits on the number of times each block can be erased and programmed.

```
static CPU_INT32U App_FileBuf[512 / 4];          /* Define file buffer.          */
                                                /*                               */

void App_Funct (void)
{
    CPU_INT08U  data1[50];
    .
    .
    .

    p_file = FS_fopen("\\file.txt", "w");
    if (p_file != (FS_FILE *)0) {
                                                /* Set buffer (see Note #1).    */
        fs_setvbuf(p_file, (void *)App_FileBuf, FS__IOFBF, sizeof(App_FileBuf));
        .
        .
        .
        fs_fflush(p_file);                    /* Make sure data is written to file. */
        .
        .
        .
        fs_fclose(p_file);                    /* When finished, close file.    */
    }
    .
    .
    .
}
```

Listing 8-3 **Example file buffer usage**

- L8-3(1) The buffer *must* be assigned immediately after opening the file. An attempt to set the buffer after read or writing the file will fail.
- L8-3(2) While it is not necessary to flush the buffer before closing the file, some applications may want to make sure at certain points that all previously written data is stored on the device before writing more.

8-3-4 DIAGNOSING A FILE ERROR

The file maintains flags that reflect errors encountered in the previous file access, and subsequent accesses will fail (under certain conditions outlined here) unless these flags are explicitly cleared (using `fs_clearerr()`). There are actually two sets of flags. One reflects whether the file encountered the end-of-file (EOF) during the previous access, and if this is set, writes will not fail, but reads will fail. The other reflects device errors, and no subsequent file access will succeed (except file close) unless this is first cleared. The functions `fs_ferror()` and `fs_feof()` can be used to get the state of device error and EOF conditions, respectively.

8-3-5 ATOMIC FILE OPERATIONS USING FILE LOCK

If a file is shared between several tasks in an application, the file lock can be employed to guarantee that a series of file operations are executed atomically. `fs_flockfile()` (or its non-blocking equivalent `fs_ftrylockfile()`) acquires the lock for a task (if it does not already own it). Accesses from other tasks will be blocked until `fs_funlockfile()` is called.

Each file actually has a lock count associated with it. This allows nested calls by a task to acquire a file lock; each of those calls must be matched with a call to `fs_funlockfile()`.

```
void App_Funct (void)
{
    unsigned char data1[50];
    unsigned char data2[10];
    .
    .
    .

    if (App_FilePtr != (FS_FILE *)0) {
        fs_flockfile(App_FilePtr);           /* Lock file.                */
                                           /* See Note #1.             */
                                           /* Wr data atomically.      */
        fs_fwrite(data1, 1, sizeof(data1), App_FilePtr);
        fs_fwrite(data2, 1, sizeof(data1), App_FilePtr);
        fs_funlockfile(App_FilePtr);        /* Unlock file.             */
    }
    .
    .
    .
}
```

Listing 8-4 Example file lock usage

L8-4(1) `fs_flockfile()` will block the calling task until the file is available. If the task must write to the file only if no other task is currently accessing it, the non-blocking function `fs_funlockfile()` can be used.

8-4 DIRECTORY ACCESS FUNCTIONS

The directory access functions provide an API for iterating through the entries within a directory. The `fs_opendir()` function initiates this procedure, and each subsequent call to `fs_readdir_r()` (until all entries have been examined) returns information about a particular entry in a struct `fs_dirent`. The `fs_closedir()` function releases any file system structures and locks.

Figure 8-2 gives an example using the directory access functions to list the files in a directory. An example result of listing a directory is shown in Figure 4-1.

```

void App_Funct (void)
{
    FS_DIR          *p_dir;
    struct fs_dirent dirent;
    struct fs_dirent *p_dirent;
    char            str[50];
    char            *p_cwd_path;
    fs_time_t       ts;
    .
    .
    .
    p_dir = fs_opendir(p_cwd_path);                /* Open dir.          */
    if (p_dir != (FS_DIR *)0) {
        (void)fs_readdir_r(p_dir, &dirent, &p_dirent); /* Rd first dir entry. */
        if (p_dirent == (FS_DIRENT *)0) {           /* If NULL ... dir is empty. */
            APP_TRACE_INFO(("Empty dir: %s.\r\n", p_cwd_path));
        } else {
            /* Fmt info for each entry. */
            Str_Copy(str, "-r--r--r--", " ");
            while (p_dirent != (struct dirent *)0) {
                /* Chk if file is dir. */
                if (DEF_BIT_IS_SET(dirent.Info.Attrib, FS_ENTRY_ATTRIB_DIR) == DEF_YES) {
                    str[0] = 'd';
                }
                /* Chk if file is rd only. */
            }
        }
    }
}

```

```

if (DEF_BIT_IS_SET(dirent.Info.Attrib, FS_ENTRY_ATTRIB_WR) == DEF_YES) {
    str[2] = 'w';
    str[5] = 'w';
    str[8] = 'w';
}
/* Get file size. */
if (p_dirent->Info.Size == 0) {
    if (DEF_BIT_IS_CLR(dirent.Info.Attrib, FS_ENTRY_ATTRIB_DIR) == DEF_YES) {
        Str_Copy(&str[11], "          0");
    }
} else {
    Str_FmtNbr_Int32U(dirent.Info.Size,
                    10, 10, '0', DEF_NO, DEF_NO, &str[11]);
}
/* Get file date/time. */
if (p_dirent->Info.DateTimeCreate.Month != 0) {
    Str_Copy(&str[22],
            (CPU_CHAR *)App_MonthNames[dirent.Info.DateTimeCreate.Month - 1]);
    Str_FmtNbr_Int32U(dirent.Info.DateTimeWr.Day,
                    2, 10, ' ', DEF_NO, DEF_NO, &str[26]);
    Str_FmtNbr_Int32U(dirent.Info.DateTimeWr.Hour,
                    2, 10, ' ', DEF_NO, DEF_NO, &str[29]);
    Str_FmtNbr_Int32U(dirent.Info.DateTimeWr.Minute,
                    2, 10, ' ', DEF_NO, DEF_NO, &str[32]);
}
/* Output info for entry. */
APP_TRACE_INFO("%s%s\r\n", str, dirent.Name);
/* Rd next dir entry. */
(void)fs_readdir_r(pdir, &dirent, &p_dirent);
}
}

fs_closedir(p_dir); /* Close dir. */
/* If dir could not be opened ... */
} else { /* ... dir does not exist. */
    APP_TRACE_INFO("Dir does not exist: %s.\r\n", p_cwd_path);
}
.
.
.
}

```

Listing 8-5 Directory listing output (example)

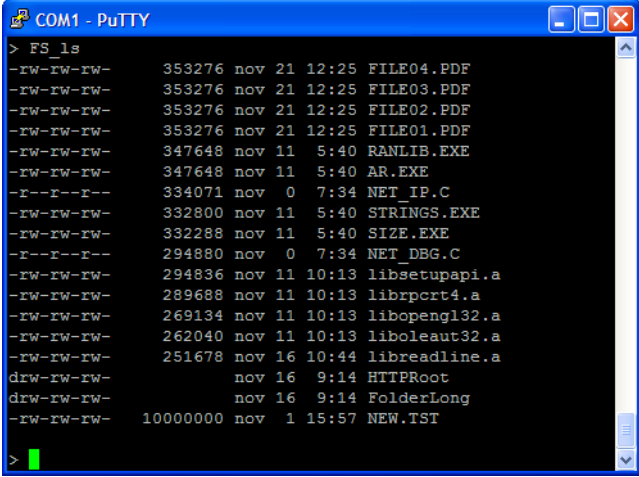

```
COM1 - PuTTY
> FS ls
-rw-rw-rw- 353276 nov 21 12:25 FILE04.PDF
-rw-rw-rw- 353276 nov 21 12:25 FILE03.PDF
-rw-rw-rw- 353276 nov 21 12:25 FILE02.PDF
-rw-rw-rw- 353276 nov 21 12:25 FILE01.PDF
-rw-rw-rw- 347648 nov 11 5:40 RANLIB.EXE
-rw-rw-rw- 347648 nov 11 5:40 AR.EXE
-r--r--r-- 334071 nov 0 7:34 NET_IP.C
-rw-rw-rw- 332800 nov 11 5:40 STRINGS.EXE
-rw-rw-rw- 332288 nov 11 5:40 SIZE.EXE
-r--r--r-- 294880 nov 0 7:34 NET_DBG.C
-rw-rw-rw- 294836 nov 11 10:13 libsetupapi.a
-rw-rw-rw- 289688 nov 11 10:13 librpcrt4.a
-rw-rw-rw- 269134 nov 11 10:13 libopengl32.a
-rw-rw-rw- 262040 nov 11 10:13 liboleaut32.a
-rw-rw-rw- 251678 nov 16 10:44 libreadline.a
drw-rw-rw- nov 16 9:14 HTTPRoot
drw-rw-rw- nov 16 9:14 FolderLong
-rw-rw-rw- 10000000 nov 1 15:57 NEW.TST
>
```

Figure 8-2 Example directory listing

The second argument `fs_readdir_r()`, is a pointer to a struct `fs_dirent`, which has two members. The first is `Name`, which holds the name of the entry; the second is `Info`, which has file information. For more information about the struct `fs_dirent` structure, see section D-5 “FS_DIR_ENTRY (struct `fs_dirent`)” on page 489.

8-5 ENTRY ACCESS FUNCTIONS

The entry access functions provide an API for performing single operations on file system entries (files and directories), such as renaming or deleting a file. Each of these operations is atomic; consequently, in the absence of device access errors, either the operation will have completed or no change to the storage device will have been made upon function return.

A new directory can be created with `fs_mkdir()` or an existing file or directory deleted or renamed (with `fs_remove()` or `fs_rename()`).

Device Drivers

The file system initializes, controls, reads and writes a device using a device driver. A μ C/FS device driver has eight interface functions, grouped into a `FS_DEV_DRV` structure that is registered with the file system (with `FS_DrvAdd()`) as part of application start-up, immediately following `FS_Init()`.

Several restrictions are enforced to preserve the uniqueness of device drivers and simplify management:

- Each device driver must have a unique name.
- No driver may be registered more than once.
- Device drivers cannot be unregistered.
- All device driver functions must be implemented (even if one or more is 'empty').

9-1 PROVIDED DEVICE DRIVERS

Portable device drivers are provided for standard media categories:

- RAM disk driver. The RAM disk driver supports using internal or external RAM as a storage medium.
- SD/MMC driver. The SD/MMC driver supports SD, SD high-capacity and MMC cards, including micro and mini form factors. Either cardmode and SPI mode can be used.
- NAND driver. The NAND flash driver support parallel (typically ONFI-compliant) NAND flash devices.
- NOR driver. The NOR flash driver support parallel (typically CFI-compliant) and serial (typically SPI) NOR flash devices.
- MSC driver. The MSC (Mass Storage Class) driver supports USB host MSC devices (i.e., thumb drives or USB drives) via μ C/USB-Host.

Table 9-1 summarizes the drivers, driver names and driver API structure names. If you require more information about a driver, please consult the listed chapter.

Driver	Driver Name	Driver API Structure Name	Reference
RAM disk	"ram:"	FSDev_RAM	Chapter 11, on page 131
SD/MMC	"sd:" / "sdcard:"	FSDev_SD_SPI / FSDev_SD_Card	Chapter 12, on page 135
NAND	"nand:"	FSDev_NAND	Chapter 13, on page 159
NOR	"nor:"	FSDev_NOR	Chapter 14, on page 199
MSC	"msc:"	FSDev_MSC	Chapter 15, on page 219

Table 9-1 Device driver API structures

If your medium is not supported by one of these drivers, a new driver can be written based on the template driver. Appendix C, "Device Driver" on page 412 describes how to do this.

9-1-1 DRIVER CHARACTERIZATION

Typical ROM requirements are summarized in Table 9-2. The ROM data were collected on IAR EWARM v6.40 with high size optimization.

Driver	ROM, Thumb Mode	ROM, ARM Mode
RAM disk	0.4 kB	0.6 kB
SD/MMC CardMode*	3.9 kB	6.2 kB
SD/MMC SPI*	4.7 kB	7.3 kB
NOR***	5.7 kB	9.1 kB
MSC**	0.6 kB	0.9 kB

Table 9-2 **Driver ROM requirements**

* Not including BSP

**Not including μ C/USB

***Using the generic controller and software ECC, not including BSP

Typical RAM requirements are summarized in Table 9-3.

Driver	RAM (Overhead)	RAM (Per Device)
MSC*	12 bytes	32 bytes
NOR***	4 bytes	--- bytes
RAM disk	4 bytes	24 bytes
SD/MMC CardMode	4 bytes	64 bytes
SD/MMC SPI	4 bytes	52 bytes

Table 9-3 **Driver RAM requirements**

*Not including μ C/USB

***See section 14-2 “Driver & Device Characteristics” on page 202.

Performance can vary significantly as a result of CPU and hardware differences, both as well as file system format. All test were compiled using IAR EWARM 6.40.1 using high speed optimization. Table 9-4 lists results for two general performance tests:

- Read file test. Read a file in 4-kB and 64kB chunks. The time to open the file is NOT included in the time.
- Write file test. Write a file in 4-kB and 64kB chunks. The time to open (create) the file is NOT included in the time.

Driver	CPU	Media	Performance (kB/s)	
			4k Read 4k Write	64k Read 64k Write
RAM Disk	ST STM32F207IGH6 120Mhz	IS61WV102416BLL-10MLI 16Mbit 10-ns SRAM	16 622 kB/s 10 839 kB/s	31 186 kB/s 26 473 kB/s
RAM Disk	Atmel AT91SAM9M10 400-Mhz	MT47H64M8CF-3-F DDR2 2x8bit 2 banks interleaved	27 478 kB/s 18 858 kB/s	96 866 kB/s 84 121 kB/s
SD/MMC CardMode	ST STM32F207IGH6 120-MHz, 4-bit mode	Nokia 64 MB SMS064FF SD Card	5 333 kB/s 661 kB/s	8 595 kB/s 1 607 kB/s
SD/MMC SPI	ST STM32F107VC 72-Mhz	Nokia 64 MB SMS064FF SD Card	947 kB/s 444 kB/s	1 010kB/s 793 kB/s
SD/MMC SPI	ST STM32F107VC 72-MHz (w/GRC)	Nokia 64 MB SMS064FF SD Card	759 kB/s 388 kB/s	800 kB/s 655 kB/s
NAND	Atmel AT91SAM9M10 400-Mhz	Micron MT29F2G08ABDHC 2Gb NAND flash	9 039 kB/s 1 950 kB/s	10 732 kB/s 4 332 kB/s
NAND (auto-sync)	Atmel AT91SAM9M10 400-Mhz	Micron MT29F2G08ABDHC 2Gb NAND flash	9 039 kB/s 1 336 kB/s	10 732 kB/s 2 695 kB/s
NOR (parallel)	ST STM32F103ZE 72-MHz	ST M29W128GL 16MB NOR flash	2 750 kB/s 158 kB/s	3 810 kB/s 310 kB/s
NOR (serial)	ST STM32F103VE 72-MHz	ST M25P64 serial flash	691 kB/s 55 kB/s	---- kB/s ---- kB/s
MSC	Atmel AT91SAM9M10 400-MHz	64-GB SanDisk Cruzer	613 kB/s 153 kB/s	2 301kB/s 883 kB/s

Table 9-4 Driver performance (file test)

9-2 DRIVERS COMPARISON

NAND flash is a low-cost on-board storage solution. Typically, NAND flash have a multiplexed bus for address and data, resulting in a much lower pin count than parallel NOR devices. Their low price-per-bit and relatively high capacities often makes these preferable to NOR, though the higher absolute cost (because the lowest-capacity devices are at least 128-Mb) reverses the logic for applications requiring very little storage.

FAT File System

Microsoft originally developed FAT (File Allocation Table) as a simple file system for diskettes and then hard disks. FAT originally ran on very early, very small microcomputers, e.g., IBM PCs with 256 KB of memory. Windows, Mac OS, Linux, and many Unix-like systems also use FAT as a file interchange format.

FAT was designed for magnetic disks, but today supports Flash memory and other storage devices.

μ C/Fs is an implementation of FAT that supports FAT12, FAT16, and FAT32. By default, μ C/Fs supports only short (8.3) file names. To enable long file names (LFNs), you must set a configuration switch. By setting this switch, you agree to contact Microsoft to obtain a license to use LFNs.

10-1 WHY EMBEDDED SYSTEMS USE FAT

Since FAT's inception, it has been extended multiple times to support larger disks as well as longer file names. However, it remains simple enough for the most resource-constrained embedded system.

Because FAT is supported by all major operating systems, it still dominates the removable storage market. USB flash drives are embedded systems, and most are formatted in FAT. Cameras, MP3 players, and other consumer electronics that depend on easy file transfer to and from the device also normally use FAT. FAT is also widely used in embedded systems, especially ones that run on microcontrollers.

10-2 ORGANIZATION OF A FAT VOLUME

As shown in Figure 10-1, a FAT volume (i.e., a logical disk) contains several *areas*:

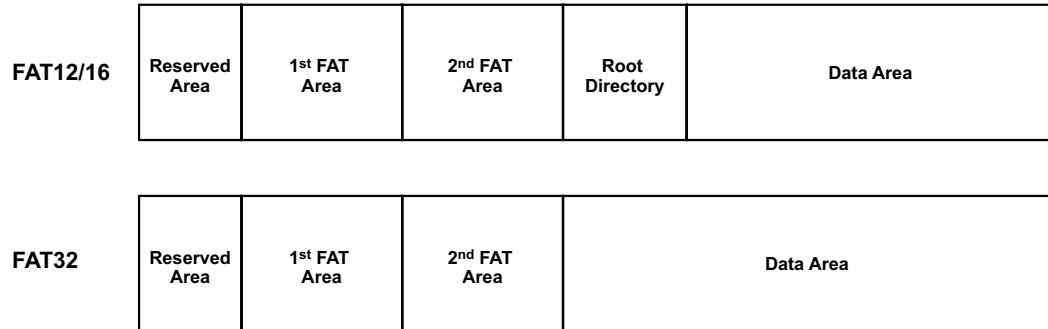

Figure 10-1 FAT volume layout

- 1 **Reserved area.** The reserved area includes the boot sector, which contains basic format information, like the number of sectors in the volume.
- 2 **File allocation table area.** The FAT file system is named after the file allocation table, a large table with one entry for each cluster in the volume. This area must contain at least one FAT area; for redundancy, it may also contain one or more additional FAT areas.
- 3 **Root directory area.** FAT 12 and FAT 16 volumes contain a fixed amount of space for the root directory, In FAT32 volumes, there is no area reserved for the root directory; the root directory is instead stored in a fixed location in the data area.
- 4 **Data area.** The data area contains files and directories. A *directory* (or *folder*) is a special type of file.

FAT supports only four attributes for its files and directories: Read-Only, Hidden, System, and Archive.

10-2-1 ORGANIZATION OF DIRECTORIES AND DIRECTORY ENTRIES

In the FAT file system, directories are just special files, composed of 32-byte structures called directory entries. The topmost directory, the root directory, is located using information in the boot sector.

The normal (short file name) entries in this directory and all other directories follow the format shown below in Figure 10-2 (long file name are discussed a little further on in section 10-3-2 “Short and Long File Names” on page 123).

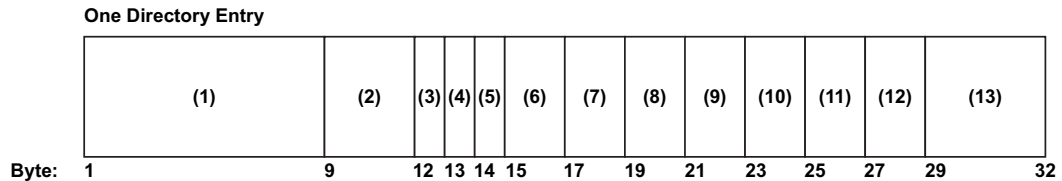

Figure 10-2 The entry for a file in a FAT directory

- F10-2(1) **Filename** is the 8-character short file name (SFN). Eight bytes.
- F10-2(2) **File extension** is the three-character file name extension. Three bytes
- F10-2(3) **File Attributes** are the attributes of the entry, indicating whether it is a file or directory, writable or read-only and visible or hidden. One byte.
- F10-2(4) **Reserved area.** One byte.
- F10-2(5) **Created Time (milliseconds)** and is the fraction of the second of the date and time the file was created. One byte.
- F10-2(6) **Created Time** is the hour, minute, and second the file was created. Two bytes.
- F10-2(7) **Created Date** is the day, month, and year the file was created. Two bytes.
- F10-2(8) **Last Accessed Day** is the day, month, and year the file was last accessed. Two byte.

- F10-2(9) **Extended Attribute Index.** In FAT16, this field is used for extended attributes for some operating systems. In FAT32, this field contains the high two bytes of the cluster address. Two bytes.
- F10-2(10) **Last Modified Time** is hour, minute, and second when the file was last modified. Two bytes.
- F10-2(11) **Last Modified Date** is the day, month, and year when the file was last modified. Two bytes.
- F10-2(12) **Cluster address** is the address of the first cluster allocated to the file (i.e., the first cluster that contains file data). In FAT16, this field contains the entire cluster address. In FAT32, this field contains the low two bytes of the cluster address. Two bytes.
- F10-2(13) **File Size** is the size of the file, in octets. If the entry is a directory, this field is blank. Four bytes.

10-3 ORGANIZATION OF THE FILE ALLOCATION TABLE

The File Allocation Table is a map of all the clusters that make up the data area of the volume. The FAT does not “know” the location of the first cluster that has been allocated to a given file. It does not even know the name of any files. That information is stored in the directory.

As described in the section above, the directory entry for each file contains a value called a *cluster address*. This is a pointer to the first entry in the File Allocation Table for a given file. This FAT entry in turn points to the first cluster in the volume’s data area that has been allocated to the file.

If the file has been allocated more than one cluster, then the FAT table entry will contain the address of the second cluster (which is also the index number of the second cluster’s entry in the FAT table). The second cluster entry points to the third, and so forth. A FAT entry like this forms a linked list commonly called a *cluster chain*.

Figure 10-3 illustrates the relationship between the directory entry and the FAT.

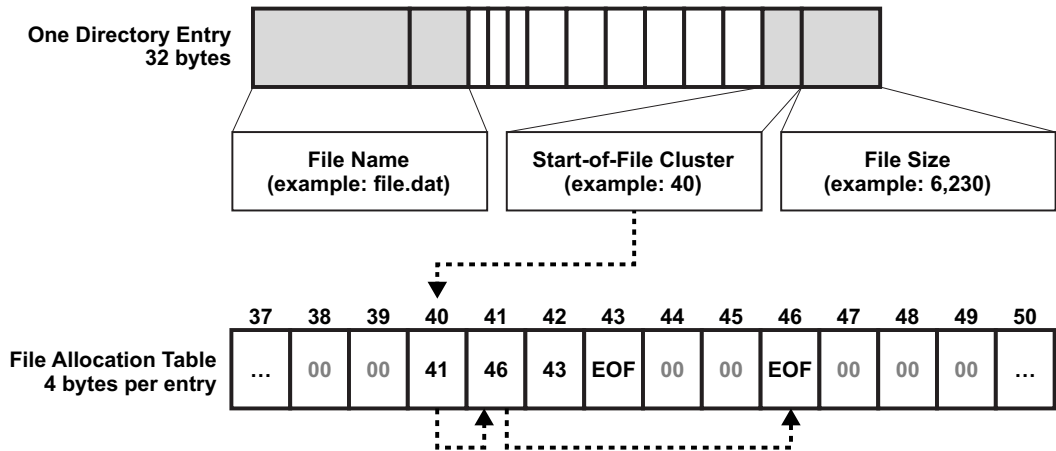

Figure 10-3 A directory entry points to the first entry in a cluster chain (FAT 16)

In Figure 10-3, the directory entry for a file points to the 40th entry in the FAT table. The 40th entry points to the 41st, the 41st to the 46th; the 46th is not a pointer, as the entry contains a special end-of-cluster-chain marker. This means that for Figure 10-3, the 41st cluster is the final cluster allocated to the file.

Other entries in the FAT area in illustrated Figure 10-3 are either not allocated to a file, or allocated to a file whose cluster chain is terminated by the 43rd entry.

To summarize, a cluster's entry in the File Allocation Table typically contains a pointer to the entry for the next cluster in a file's cluster chain.

Other values that can be stored in a cluster's entry in the FAT are special markers for:

- End-of-cluster-chain: this cluster is the final cluster for a file.
- Cluster-not-allocated (*free cluster mark*): no file is using this cluster.
- Damaged-cluster: this cluster cannot be used.

NOTE: Updating the FAT table is time consuming, but updating it frequently is very important. If the FAT table gets out of sync with its files, files and directories can become corrupted, resulting in the loss of data (see See "Optional Journaling System" on page 127.).

10-3-1 FAT12 / FAT16 / FAT32

The earliest version of FAT, the file system integrated into MS-DOS, is now called FAT12, so-called because each cluster address in the File Allocation Table is 12 bits long. This limits disk size to approximately 32 MB. Extensions to 16- and 32-bit addresses (i.e., FAT16 and FAT32), expand support to 2 GB and 8 TB, respectively.

FAT version	Pointer size (Table entry size)	Max. size of disk	Free cluster marker	Damaged cluster marker	End of cluster chain marker
FAT12	12 bits	32 MB	0	0xff7	0xff8
FAT16	16 bits	2 GB	0	0xffff7	0xffff8
FAT32	32 bits	8 TB	0	0x0fff fff7	0x0fff fff8

In μ C/FS, you can enable support for FAT12, FAT16 and FAT32 individually: this means that you can enable only the FAT version that you need for your embedded system (see Appendix E, “ μ C/FS Configuration” on page 497).

FAT32 introduced some innovations:

- The root directory in the earlier systems was a fixed size; i.e., when the medium is formatted, the maximum number of files that could be created in the root directory (typically 512) is set. In FAT32, the root directory is dynamically resizable, like all other directories.
- Two special sectors have been added to the volume: the FS info sector and the backup boot sector. The former stores information convenient to the operation of the host, such as the last used cluster. The latter is a copy of the first disk sector (the boot sector), in case the original is corrupted.

10-3-2 SHORT AND LONG FILE NAMES

In the original version of FAT, files could only carry short “8 dot 3” names, with eight or fewer characters in the main name and three or fewer in its extension. The valid characters in these names are letters, digits, characters with values greater than 0xFF and the following:

\$ % ' - _ @ ~ ` ! () { } ^ # &

In μ C/FS, the name passed by the application is always verified, both for invalid length and invalid characters. If valid, the name is converted to upper case for storage in the directory entry. Accordingly, FAT file names are not case-sensitive.

Later, in a backwards-compatible extension, Microsoft introduced long file names (LFN). LFNs are limited to 255 characters stored as 16-bit Unicode in long directory entries. Each LFN is stored with a short file name (SFN) created by truncating the LFN and attaching a numeric “tail” to the original; this results in names like “file~1.txt”. In addition to the characters allowed in short file names (SFN), the following characters are allowed in LFNs:

+ , ; = []

As described in section E-7 “FAT Configuration” on page 505, support for LFNs can be disabled, if desired. If LFNs are enabled, the application may choose to specify file names in UTF-8 format, which will be converted to 16-bit Unicode for storage in directory entries. This option is available if `FS_CFG_UTF8_EN` is `DEF_ENABLED` (see Appendix E, “Feature Inclusion Configuration” on page 500).

ENTRIES FOR FILES THAT HAVE LONG FILE NAMES

To allow FAT to support long file names, Microsoft devised the LFN directory entry, as shown in Figure 10-4.

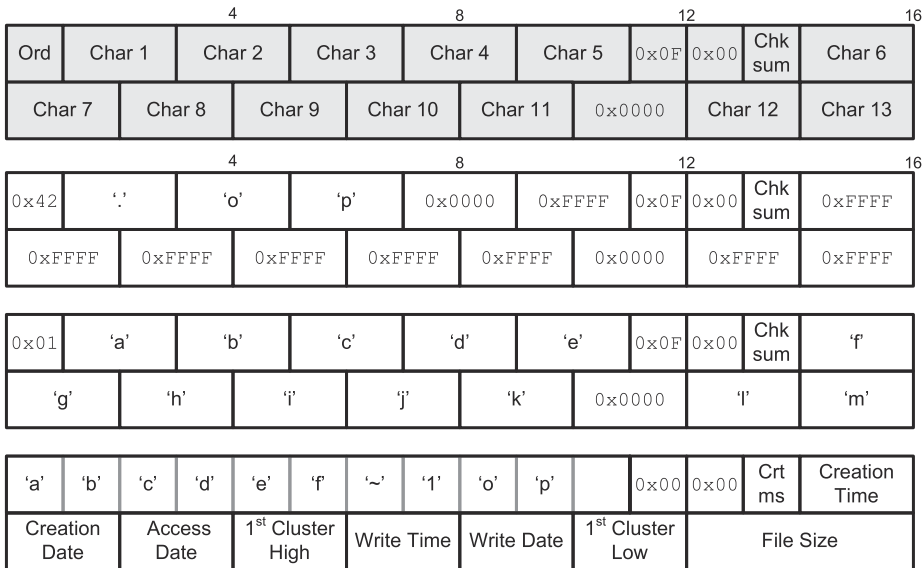

Figure 10-4 LFN directory entry

An LFN entry is essentially a workaround to store long file names in several contiguous 32-byte entries that were originally intended for short file names.

A file with an LFN also has a SFN this is derived from the LFN. The last block of an LFN stores the SFN that corresponds to the LFN. The two or more preceding blocks each store parts of the LFN. Figure 10-4 shows four “blocks”

- The first block shows the names for the fields in an LFN entry; the actual LFN entry is shown in the next three blocks.
- The middle two blocks show how FAT stores the LFN for a file named “abcdefghijklm.op” in two 32-byte FAT table entries.

- The final block shows how FAT stores the SFN derived from the LFN. In this case, the SFN is “abcdef~1.op” Note that the “.” of an 8.3 filename is not actually stored.

The final 32 bytes for an LFN entry has the same fields as the 32-byte entry for (in this example) a file with a SFN of “abcdef~1.op”. Accordingly, it is able to store, in addition to the file’s SFN, the properties (creation date and time, etc.) for file “abcdefghijklm.op”.

- Together, the three blocks make up one LFN directory entry, in this case the LFN entry for file “abcdefghijklm.op”.

A long file name is stored in either two or three 32-bit entries of a directory table:

- If three entries are needed to store the long file name, byte 0 of the entries carry *order numbers* of **0x43**, **0x02** and **0x01**, respectively. (Byte 0 is labelled “**Ord**” in Figure 10-4). None of these, are valid characters (which allows backward compatibility).
- If two entries are needed (as in Figure 10-4), byte 0 of the entries carry order numbers of **0x43** and **0x01**, respectively.
- In entries that store part of a LFN, byte 11, where the Attributes value is stored in a SFN, is always **0x0F**; Microsoft found that no software would modify or use a directory entry with this marker.
- In entries that store part of a LFN, byte 13 contains the checksum, which is calculated from the SFN. FAT’s file system software recalculates the checksum each time it parses the directory entries. If the stored checksum is not the same as the recalculated checksum, FAT’s file system software knows that the SFN was modified (presumably by a program that is not LFN-aware).

10-4 FORMATTING

A volume, once it is open, may need to be formatted before files or directories can be created. The default format is selected by passing a NULL pointer as the second parameter of `FSVol_Fmt()`. Alternatively, the exact properties of the file system can be configured with a `FS_FAT_SYS_CFG` structure. An example of populating and using the FAT configuration is shown in Listing 10-1. If the configuration is invalid, an error will be returned from `FSVol_Fmt()`. For more information about the `FS_FAT_SYS_CFG` structure, see Appendix D, “FS_FAT_SYS_CFG” on page 492.

```
void App_InitFS (void)
{
    FS_ERR      err;
    FS_FAT_SYS_CFG fat_cfg;
    .
    .
    .
    fat_cfg.ClusSize      = 4;           /* Cluster size      = 4 * 512-B = 2-kB.*/
    fat_cfg.RsvdAreaSize = 1;           /* Reserved area     = 1 sector.    */
    fat_cfg.RootDirEntryCnt = 512;      /* Entries in root dir = 512.        */
    fat_cfg.FAT_Type      = 12;         /* FAT type          = FAT12.        */
    fat_cfg.NbrFATs       = 2;         /* Number of FATs    = 2.            */
    FSVol_Fmt("ram:0:", &fat_cfg, &err);
    if (err != FS_ERR_NONE) {
        APP_TRACE_DEBUG(("Format failed.\r\n"));
    }
    .
    .
    .
}
```

Listing 10-1 Example device format

10-5 SOURCES OF CORRUPTION IN FAT VOLUMES

Errors may accrue on a FAT volume, either by device removal during file system modifications, power loss, or by improper host operation. Several corruptions are common:

- Cross-linked files. If a cluster becomes linked to two files, then it is called “cross-linked”. The only way to resolve this is by deleting both files; if necessary, they can be copied first so that the contents can be verified.
- Orphaned directory entries. If LFNs are used, a single file name may span several directory entries. If a file deletion is interrupted, some of these may be left behind or “orphaned” to be deleted later.
- Invalid cluster. The cluster specified in a directory entry or linked in a chain may be invalid. The only recourse is to zero the cluster (if in a directory entry) or replace with end-of-cluster (if in a chain).
- Chain length mismatch. Too many or too few clusters may be linked to a file, compared to its size. If too many, the extra clusters should be freed. If too few, the file size should be adjusted.
- Lost cluster. A lost cluster is marked as allocated in the FAT, but is not linked to any file. Optionally, lost cluster chains may be recovered to a file.

10-6 OPTIONAL JOURNALING SYSTEM

Since cluster allocation information is stored separately from file information and directory entries, even file operations that make a simple change to one file (e.g., adding data to the end of a file, updating data in place) are *non-atomic*. An atomic operation is made up of a set of sub-operations which must all be completed; the atomic operation is completed successfully only if all the sub-operations complete successfully.

The repercussions can be innocuous (e.g., wasted disk space) or very serious: corrupted directories, corrupted files, and lost data (see section 10-5 “Sources of Corruption in FAT volumes” on page 127).

One way that $\mu\text{C}/\text{FS}$ reduces the risk of corruption by ordering modifications wisely, for example, by forcing an update to the FAT after every Write operation. It also has an optional *journaling system* that allows you to log data about impending and completed changes to files and directories.

Without the journaling system, any atomic operation, even a single Write operation (at the API level), can be interrupted by a power failure or a crash of the application or the operating system.

Accordingly, FAT file systems without *journaling* are not fail-safe. Journaling means that a file system logs all changes to a journal before committing them to the main file system. Each file system operation is then in fact done twice. Journaling protects the file system at the expense of time.

Data can be lost in case of unexpected Reset in either the File System Layer or in the Device Driver Layer. Your entire system is fail-safe only if **both** layers are fail-safe. The journaling add-on makes the file system layer fail-safe. Your entire system is only fail-safe if the driver layer is fail-safe as well. The device drivers supplied with $\mu\text{C}/\text{FS}$ are each fail-safe, as the chapter for each specific driver shows.

10-7 LICENSING ISSUES

There are licensing issues related to FAT, particularly relating to Microsoft patents that deal with long file names (LFNs).

10-7-1 LICENSES FOR LONG FILE NAMES (LFNS)

Microsoft announced on 2003-12-03 that it would be offering licenses for use of its FAT specification and "associated intellectual property". The royalty for using LFNs is US \$0.25 royalty per unit sold, with a maximum of US \$250,000 per license agreement.

Micrium μ C/FS is delivered with complete source code for FAT; this includes source code for LFNs. To enable long file names (LFNs), you must set a configuration switch. By setting this switch, you agree to contact Microsoft to obtain a license to use LFNs.

10-7-2 EXTENDED FILE ALLOCATION TABLE (EXFAT)

Microsoft has developed a new, proprietary file system: exFAT, also known as FAT64. exFAT was designed to handle very large storage media. Microsoft requires a license to make or distribute implementations of exFAT.

Micrium does not offer exFAT in μ C/FS at this time.

RAM Disk Driver

The simplest device driver is the RAM disk driver, which uses a block of memory (internal or external) as a storage medium.

11-1 FILES AND DIRECTORIES

The files inside the RAM disk driver directory are outlined in this section; the generic file-system files, outlined in Chapter 3, “ μ C/FS Directories and Files” on page 29, are also required.

`\Micrium\Software\uC-FS\Dev`

This directory contains device-specific files.

`\Micrium\Software\uC-FS\Dev\RAMDisk`

This directory contains the RAM disk driver files.

`fs_dev_ramdisk.*` constitute the RAM disk device driver.

11-2 USING THE RAM DISK DRIVER

To use the RAM disk driver, two files, in addition to the generic FS files, must be included in the build:

- `fs_dev_ramdisk.c`.
- `fs_dev_ramdisk.h`.

The file `fs_dev_ramdisk.h` must also be `#included` in any application or header files that directly reference the driver (for example, by registering the device driver). The following directory must be on the project include path:

- `\Micrium\Software\uC-FS\Dev\RAMDisk`

A single RAM disk is opened as shown in . The file system initialization (`FS_Init()`) function must have previously been called.

ROM/RAM characteristics and performance benchmarks of the RAM disk driver can be found in section 9-1-1 “Driver Characterization” on page 113. For more information about the `FS_DEV_RAM_CFG` structure, see section D-4 “`FS_DEV_RAM_CFG`” on page 488.

```
#define APP_CFG_FS_RAM_SEC_SIZE          512      /* (1) */
#define APP_CFG_FS_RAM_NBR_SECS        (48 * 1024)
static CPU_INT32U App_FS_RAM_Disk[APP_CFG_FS_RAM_SEC_SIZE * APP_CFG_FS_RAM_NBR_SECS / 4];
CPU_BOOLEAN App_FS_AddRAM (void)
{
    FS_ERR      err;
    FS_DEV_RAM_CFG cfg;
    FS_DrvAdd((FS_DEV_API *)&FSDev_RAM,          /* (2) */
              (FS_ERR *)&err);
    if ((err != FS_ERR_NONE) && (err != FS_ERR_DEV_DRV_ALREADY_ADDED)) {
        return (DEF_FAIL);
    }
    ram_cfg.SecSize = APP_CFG_FS_RAM_SEC_SIZE;    /* (3) */
    ram_cfg.Size    = APP_CFG_FS_RAM_NBR_SECS;
    ram_cfg.DiskPtr = (void *)&App_FS_RAM_Disk[0]
}
```



```

/* (4) */
FSDev_Open((CPU_CHAR *)"ram:0:", /* (a) */
           (void *)&ram_cfg, /* (b) */
           (FS_ERR *)&err);
if (err != FS_ERR_NONE) {
    return (DEF_FAIL);
}

/* (5) */
FSVol_Open((CPU_CHAR *)"ram:0:", /* (a) */
           (CPU_CHAR *)"ram:0:", /* (b) */
           (FS_PARTITION_NBR ) 0, /* (c) */
           (FS_ERR *)&err);

switch (err) {
case FS_ERR_NONE:
    APP_TRACE_DBG((" ...opened volume (mounted).\r\n"));
    break;
case FS_ERR_PARTITION_NOT_FOUND: /* Volume error. */
    APP_TRACE_DBG((" ...opened device (not formatted).\r\n"));

    FSVol_Fmt("ram:0:", (void *)0, &err); /* (6) */
    if (err != FS_ERR_NONE) {
        APP_TRACE_DBG((" ...format failed.\r\n"));
        return (DEF_FAIL);
    }
    break;
default: /* Device error. */
    APP_TRACE_DBG((" ...opening volume failed w/err = %d.\r\n\r\n", err));
    return (DEF_FAIL);
}
return (DEF_OK);
}

```

Listing 11-1 Opening a RAM disk volume

- L11-1(1) The sector size and number of sectors in the RAM disk must be defined. The sector size should be 512, 1024, 2048 or 4096; the number of sectors will be determined by your application requirements. This defines a 24-MB RAM disk (49152 512-B sectors). On most CPUs, it is beneficial to 32-bit align the RAM disk, since this will speed up access.
- L11-1(2) Register the RAM disk driver `FSDev_RAM`.
- L11-1(3) The RAM disk parameters—sector size, size (in sectors) and pointer to the disk—should be assigned to a `FS_DEV_RAM_CFG` structure.

- L11-1(4) **FSDev_Open()** opens/initializes a file system device. The parameters are the device name (3a) and a pointer to a device driver-specific configuration structure (3b). The device name (3a) is composed of a device driver name (“ram”), a single colon, an ASCII-formatted integer (the unit number) and another colon.

- L11-1(5) **FSVol_Open()** opens/mounts a volume. The parameters are the volume name (5a), the device name (5b) and the partition that will be opened (5c). There is no restriction on the volume name (5a); however, it is typical to give the volume the same name as the underlying device. If the default partition is to be opened, or if the device is not partitioned, then the partition number (5c) should be zero.

- L11-1(6) **FSVol_Fmt()** formats a file system volume. If the RAM disk is in volatile RAM, it has no file system on it after it is opened (it will be unformatted) and must be formatted before a volume on it is opened.

If the RAM disk initialization succeeds, the file system will produce the trace output as shown in Figure 11-1 (if a sufficiently high trace level is configured). See section E-9 “Trace Configuration” on page 507 about configuring the trace level.

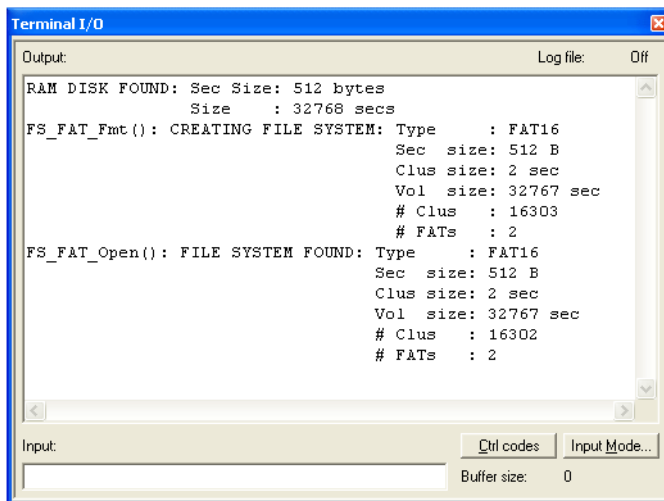

Figure 11-1 RAM disk initialization trace output

SD/MMC Drivers

SD (Secure Digital) cards and MMCs (MultiMedia Cards) are portable, low-cost media often used for storage in consumer devices. Six variants, as shown in Table 12-1, are widely available to electronic retail outlets, all supported by SD/MMC driver. The MMCplus and SD or SDHC are offered in compatible large card formats. Adapters are offered for the remaining devices so that these can fit in standard SD/MMC card slots.

Two further products incorporating SD/MMC technology are emerging. First, some cards now integrate both USB and SD/MMC connectivity, for increased ease-of-access in both PCs and embedded devices. The second are embedded MMC (trademarked eMMC), fixed flash-based media addressed like MMC cards.







	Card	Size	Pin Count	Description
MMCPPlus		32 x 24 x 1.4 mm	13	Most current MMC cards can operate with 1, 4 or 8 data lines, though legacy media were limited to a single data line. The maximum clock frequency is 20 MHz, providing for maximum theoretical transfer speeds of 20 MB/s, 80 MB/s and 160 MB/s for the three possible bus widths.
MMCmobile		18 x 24 x 1.4 mm	13	
MMCmicro		14 x 12 x 1.1 mm	13	
SD or SDHC		32 x 24 x 1.4 mm	9	SD cards can operate in cardmode with 1 or 4 data lines or in SPI mode. The maximum clock frequency is 25 MHz, providing for maximum theoretical transfer speeds of 25 MHz and 50 MHz for the two possible bus widths.
SDmini		21.5 x 20 x 1.4 mm	11	
SDmicro		15 x 11 x 1.0 mm	8	

Table 12-1 SD/MMC devices

SD/MMC cards can be used in two modes: **card mode** (also referred to as MMC mode and SD mode) and **SPI mode**. The former offers up to 8 data lines (depending on the type of card); the latter, only one data line, but the accessibility of a communication bus common on many MCUs/MPUs. Because these modes involve different command protocols, they require different drivers.

12-1 FILES AND DIRECTORIES

The files inside the SD/MMC driver directory is outlined in this section; the generic file-system files, outlined in Chapter 3, “ μ C/FS Directories and Files” on page 29, are also required.

\Micrium\Software\uC-FS\Dev

This directory contains device-specific files.

\Micrium\Software\uC-FS\Dev\SD

This directory contains the SD/MMC driver files.

`fs_dev_sd.*` contain functions and definitions required for both SPI and card modes.

\Micrium\Software\uC-FS\Dev\SD\Card

This directory contains the SD/MMC driver files for card mode.

`fs_dev_sd_card.*` are device driver for SD/MMC cards using card mode. This file requires a set of BSP functions be defined in a file named `fs_dev_sd_card_bsp.c` to work with a certain hardware setup.

`.\BSP\Template\fs_dev_sd_card_bsp.c` is a template BSP. See section C-5 “SD/MMC Cardmode BSP” on page 425 for more information.

\Micrium\Software\uC-FS\Dev\SD\SPI

This directory contains the SD/MMC driver files for SPI mode.

`fs_dev_sd_spi.*` are device driver for SD/MMC cards using SPI mode. This file requires a set of BSP functions be defined in a file named `fs_dev_sd_spi_bsp.c` to work with a certain hardware setup.

`.\BSP\Template\fs_dev_sd_spi_bsp.c` is a template BSP. See section C-6 “SD/MMC SPI mode BSP” on page 452 for more information.

`.\BSP\Template (GPIO)\fs_dev_sd_spi_bsp.c` is a template GPIO (bit-banging) BSP. See section C-6 “SD/MMC SPI mode BSP” on page 452 for more information.

\Micrium\Software\uC-FS\Examples\BSP\Dev\SD\Card

Each subdirectory contains an example BSP for a particular platform. These are named according to the following rubric:

<Chip Manufacturer>\<Board or CPU>\fs_dev_sd_card_bsp.c

\Micrium\Software\uC-FS\Examples\BSP\Dev\SD\SPI

Each subdirectory contains an example BSP for a particular platform. These are named according to the following rubric:

<Chip Manufacturer>\<Board or CPU>\fs_dev_sd_spi_bsp.c

12-2 USING THE SD/MMC CARDMODE DRIVER

To use the SD/MMC cardmode driver, five files, in addition to the generic file system files, must be included in the build:

- fs_dev_sd.c.
- fs_dev_sd.h.
- fs_dev_sd_card.c.
- fs_dev_sd_card.h.
- fs_dev_sd_card_bsp.c.

The file `fs_dev_sd_card.h` must also be `#included` in any application or header files that directly reference the driver (for example, by registering the device driver). The following directories must be on the project include path:

- \Micrium\Software\uC-FS\Dev\SD
- \Micrium\Software\uC-FS\Dev\SD\Card

A single SD/MMC volume is opened as shown in Listing 12-1. The file system initialization (`FS_Init()`) function must have previously been called.

ROM/RAM characteristics and performance benchmarks of the SD/MMC driver can be found in section 9-1-1 “Driver Characterization” on page 113. The SD/MMC driver also provides interface functions to get low-level card information and read the Card ID and Card-Specific Data registers (see section A-12 “FAT System Driver Functions” on page 386).

```

CPU_BOOLEAN App_FS_AddSD_Card (void)
{
    FS_ERR      err;

    FS_DrvAdd((FS_DEV_API *)&FSDev_SD_Card,      /* (1) */
              (FS_ERR *)&err);
    if ((err != FS_ERR_NONE) && (err != FS_ERR_DEV_DRV_ALREADY_ADDED)) {
        return (DEF_FAIL);
    }

    FSDev_Open((CPU_CHAR *)"sdcard:0:",          /* (2) */
               (void *) 0,                       /* (a) */
               (FS_ERR *)&err);                 /* (b) */

    switch (err) {
        case FS_ERR_NONE:
            break;

        case FS_ERR_DEV:
        case FS_ERR_DEV_IO:
        case FS_ERR_DEV_TIMEOUT:
        case FS_ERR_DEV_NOT_PRESENT:
            return (DEF_FAIL);
        default:
            return (DEF_FAIL);
    }

    FSVol_Open((CPU_CHAR *)"sdcard:0:",         /* (3) */
               (CPU_CHAR *)"sdcard:0:",        /* (a) */
               (FS_PARTITION_NBR ) 0,          /* (b) */
               (FS_ERR *)&err);                /* (c) */
}

```

```
switch (err) {
    case FS_ERR_NONE:
        APP_TRACE_DBG(("    ...opened volume (mounted).\r\n"));
        break;
    case FS_ERR_DEV:
    case FS_ERR_DEV_IO:
    case FS_ERR_DEV_TIMEOUT:
    case FS_ERR_DEV_NOT_PRESENT:
    case FS_ERR_PARTITION_NOT_FOUND:
        APP_TRACE_DBG(("    ...opened device (unmounted).\r\n"));
        return (DEF_FAIL);
    default:
        APP_TRACE_DBG(("    ...opening volume failed w/err = %d.\r\n\r\n", err));
        return (DEF_FAIL);
}
return (DEF_OK);
}
```

Listing 12-1 **Opening a SD/MMC device volume**

- L12-1(1) Register the SD/MMC CardMode device driver `FSDev_SD_Card`.
- L12-1(2) `FSDev_Open()` opens/initializes a file system device. The parameters are the device name (1a) and a pointer to a device driver-specific configuration structure (1b). The device name (1a) is composed of a device driver name (“sdcard”), a single colon, an ASCII-formatted integer (the unit number) and another colon. Since the SD/MMC CardMode driver requires no configuration, the configuration structure (1b) should be passed a NULL pointer.
- Since SD/MMC are often removable media, it is possible for the device to not be present when `FSDev_Open()` is called. The device will still be added to the file system and a volume opened on the (not yet present) device. When the volume is later accessed, the file system will attempt to refresh the device information and detect a file system (see section 5-2 “Using Devices” on page 69 for more information).
- L12-1(3) `FSVol_Open()` opens/mounts a volume. The parameters are the volume name (2a), the device name (2b) and the partition that will be opened (2c). There is no restriction on the volume name (2a); however, it is typical to give the volume the same name as the underlying device. If the default partition is to be opened, or if the device is not partitioned, then the partition number (2c) should be zero.

If the SD/MMC initialization succeeds, the file system will produce the trace output as shown in Figure 12-1 (if a sufficiently high trace level is configured). See section E-9 “Trace Configuration” on page 507 about configuring the trace level.

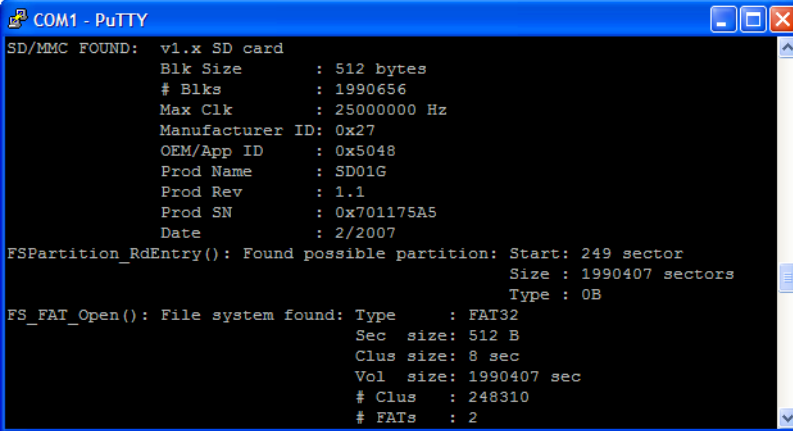

```

COM1 - PuTTY
SD/MMC FOUND: v1.x SD card
Blk Size      : 512 bytes
# Blks       : 1990656
Max Clk      : 25000000 Hz
Manufacturer ID: 0x27
OEM/App ID   : 0x5048
Prod Name    : SD01G
Prod Rev     : 1.1
Prod SN      : 0x701175A5
Date        : 2/2007

FSPartition_RdEntry(): Found possible partition: Start: 249 sector
                                                             Size : 1990407 sectors
                                                             Type : 0B

FS_FAT_Open(): File system found: Type      : FAT32
                                       Sec size: 512 B
                                       Clus size: 8 sec
                                       Vol size: 1990407 sec
                                       # Clus  : 248310
                                       # FATs  : 2
  
```

Figure 12-1 SD/MMC detection trace output

12-2-1 SD/MMC CARDMODE COMMUNICATION

In card mode, seven, nine or thirteen pins on the SD/MMC device are used, with the functions listed in the table below. All cards start up in “1 bit” mode (upon entering identification mode), which involves only a single data line. Once the host (the MCU/MPU) discovers the capabilities of the card, it may initiate 4- or 8-bit communication (the latter available only on new MMCs). Some card holders contain circuitry for card detect and write protect indicators, which the MCU/MPU may also monitor.

Pin	Name	Type	Description
1	CD/DAT3	I/O	Card Detect/Data Line (Bit 3)
2	CMD	I/O	Command/Response
3	Vss1	S	Supply voltage ground
4	VDD	S	Supply voltage
5	CLK	I	Clock
6	VSS2	S	Supply voltage ground
7	DAT0	I/O	Data Line (Bit 0)

Pin	Name	Type	Description
8	DAT1	I/O	Data Line (Bit 1)
9	DAT2	I/O	Data Line (Bit 2)
10	DAT4	I/O	Data Line (Bit 4)*
11	DAT5	I/O	Data Line (Bit 5)*
12	DAT6	I/O	Data Line (Bit 6)*
13	DAT7	I/O	Data Line (Bit 7)*

Table 12-2 SD/MMC pinout (Card mode)

*Only present in MMC cards.

Exchanges between the host and card begin with a command (sent by the host on the CMD line), often followed by a response from the card (also on the CMD line); finally, one or more blocks data may be sent in one direction (on the data line(s)), each appended with a CRC.

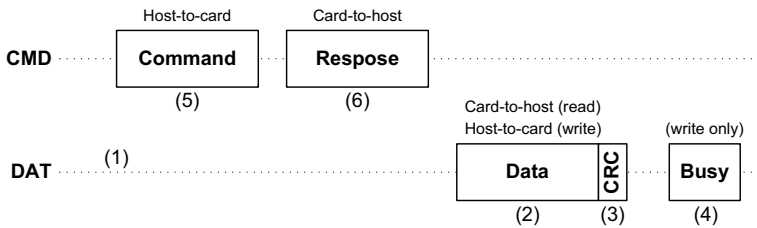

Figure 12-2 SD/MMC communication sequence

- F12-2(1) When no data is being transmitted, data lines are held low.
- F12-2(2) Data block is preceded by a start bit ('0'); an end bit ('1') follows the CRC.
- F12-2(3) The CRC is the 16-bit CCITT CRC.
- F12-2(4) During the busy signaling following a write, DAT0 only is held low.
- F12-2(5) See Figure 12-3 for description of the command format.
- F12-2(6) See Figure 12-3 for description of the command format.

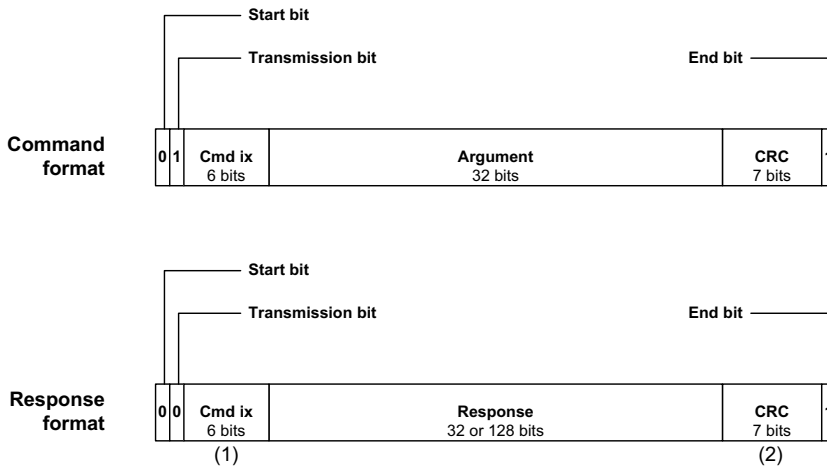

Figure 12-3 SD/MMC command and response formats

F12-3(1) Command index is not valid for response formats R2 and R3.

F12-3(2) CRC is not valid for response format R3.

When a card is first connected to the host (at card power-on), it is in the 'inactive' state, awaiting a `GO_IDLE_STATE` command to start the initialization process, which is dependent on the card type. During initialization, the card starting in the 'idle' state moves through the 'ready' (as long as it supports the voltage range specified by the host) and 'identification' states (if it is assigned an address by or is assigned an address) before ending up in 'standby'. It can now get selected by the host for data transfers. Figure 15-9 flowcharts this procedure.

12-2-2 SD/MMC CARDMODE COMMUNICATION DEBUGGING

The SD/MMC cardmode driver accesses the hardware through a port (BSP). A new BSP developed according to MCU/MPU documentation or by example must be verified step-by-step until flawless operation is achieved:

- 1 Initialization (1-bit). Initialization must succeed for a SD/MMC card in 1-bit mode.
- 2 Initialization (4- or 8-bit). Initialization must succeed for a SD/MMC card in 4 or 8-bit mode.
- 3 Read data. Data must be read from card, in both single- and multiple-block transactions.
- 4 Write data. Data must be written to the card, in both single and multiple-block transactions, and subsequently verified (by reading the modified sectors and comparing to the intended contents).

The (1-bit) initialization process reveals that commands can be executed and responses are returned with the proper bits in the correct byte-order. Example responses for each step in the sequence are given in Figure 12-5 and Figure 12-6. The first command executed, `GO_IDLE_STATE`, never receives a response from the card. Only V2 SD cards respond to `SEND_IF_COND`, returning the check pattern sent to the card and the accepted voltage range. The OCR register, read with `SD_SEND_OP_COND` or `SEND_OP_COND`, assumes basically the same format for all card types. Finally, the CID (card ID) and CSD (card-specific data) registers are read—the only times ‘long’ (132-bit) responses are returned.

Multiple-bit initialization (often 4-bit) when performed on a SD card further confirms that the 8-byte SCR register and 64-byte SD status can be read and that the bus width can be set in the BSP. Though all current cards support 4-bit mode operation, the `SD_BUS_WIDTHS` field of the SCR is checked before configure the card bus width. Afterwards, the 64-byte SD status is read to see whether the bus width change was accomplished. When first debugging a port, it may be best to force multi-bit operation disabled by returning 1 from the BSP function `FSDev_SD_Card_BSP_GetBusWidthMax()`.

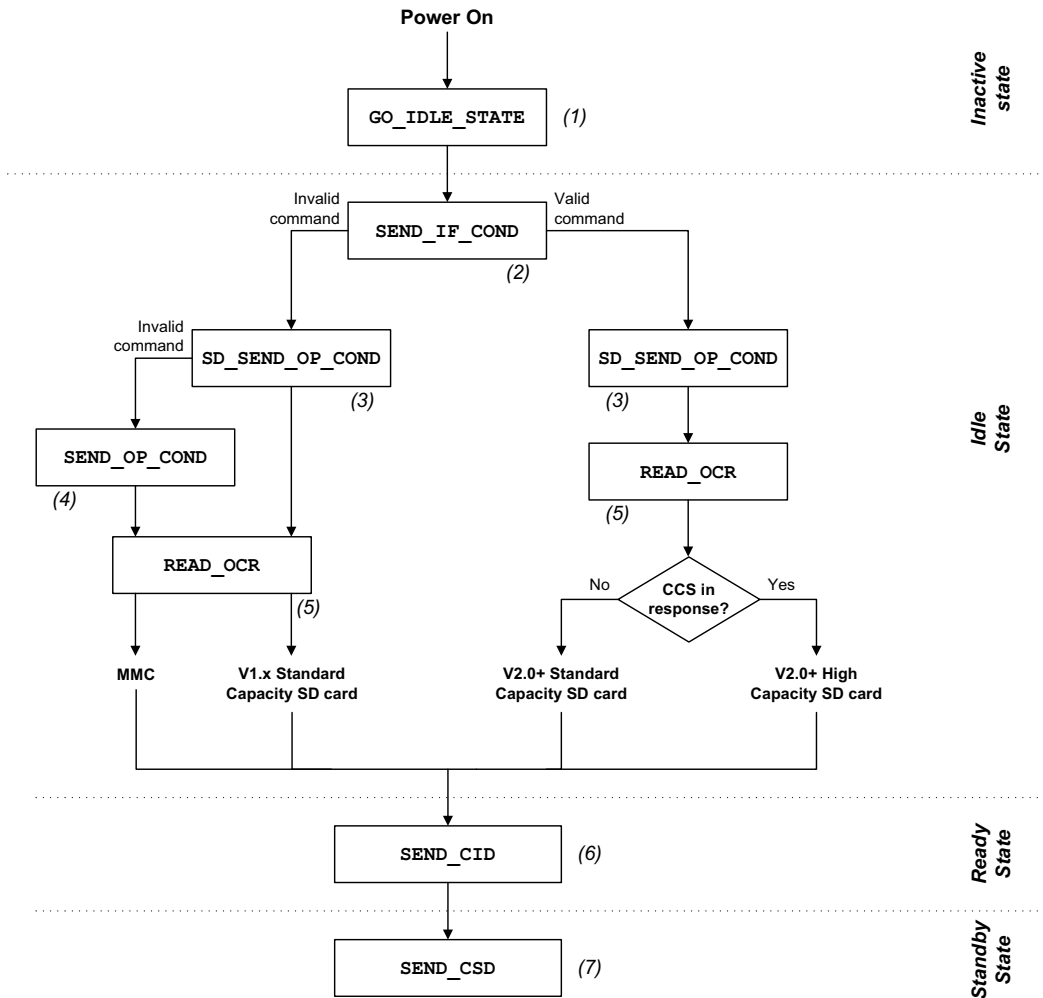

Figure 12-4 Simplified SD/MMC cardmode initialization and state transitions

Command	Response																								
GO_IDLE_STATE Fig 15-6 (1)	No response																								
SEND_IF_COND Fig 15-6 (2)	Response only for SD V2 cards <table border="1" style="margin-left: 20px;"> <tr> <td style="width: 100px;">Reserved 0x00000 20 bits</td> <td style="width: 50px;">0x1 4 bits</td> <td style="width: 50px;">Voltage range Check pattern 0xA5 8 bits</td> </tr> </table>	Reserved 0x00000 20 bits	0x1 4 bits	Voltage range Check pattern 0xA5 8 bits																					
Reserved 0x00000 20 bits	0x1 4 bits	Voltage range Check pattern 0xA5 8 bits																							
SD_SEND_OP_COND Fig 15-6 (3)	<table border="1" style="margin-left: 20px;"> <tr> <td style="width: 10px;">1x</td> <td style="width: 40px;">Reserved 0x00 6 bits</td> <td style="width: 100px;">VDD Voltage Window 0xFF8000 24 bits</td> </tr> </table> <p style="text-align: center;">OCR</p> <p> Card power up status May not be 1 on initial reading(s) Card Capacity Status 1 = High capacity, 0 = Standard capacity </p>	1x	Reserved 0x00 6 bits	VDD Voltage Window 0xFF8000 24 bits																					
1x	Reserved 0x00 6 bits	VDD Voltage Window 0xFF8000 24 bits																							
ALL_SEND_CID Fig 15-6 (5)	<table border="1" style="margin-left: 20px;"> <tr> <td style="width: 10px;">127</td> <td style="width: 40px;">MID</td> <td style="width: 40px;">OID</td> <td style="width: 40px;">PNM</td> </tr> <tr> <td style="width: 10px;">63</td> <td style="width: 40px;">PRV</td> <td colspan="2" style="width: 80px;">PSN</td> </tr> <tr> <td></td> <td style="width: 40px;">MDT</td> <td style="width: 40px;">CRC</td> <td></td> </tr> </table> <div style="margin-left: 20px;"> <p> MID = Manufacturer ID = 0x03 OID = OEM/Application ID = 0x5344 PNM = Product name = 0x5344303247 = "SD02G" PRV = Product revision = 0x80 = 8.0 PSN = Product serial number = 0x021A7C83 MDT = Manufacturing date = 0x008 </p> </div> <div style="margin-left: 20px; border: 1px solid gray; padding: 5px; background-color: #f0f0f0;"> <p>Example</p> <p>0x03534453 0x44303247 0x80021A7C 0x83008B3A</p> </div>	127	MID	OID	PNM	63	PRV	PSN			MDT	CRC													
127	MID	OID	PNM																						
63	PRV	PSN																							
	MDT	CRC																							
SEND_CSD Fig 15-6 (6)	<table border="1" style="margin-left: 20px;"> <tr> <td style="width: 10px;">127</td> <td style="width: 40px;">TAAC</td> <td style="width: 40px;">NSAC</td> <td style="width: 40px;">TRAN_SPEED</td> </tr> <tr> <td style="width: 10px;">63</td> <td style="width: 40px;">CCC</td> <td colspan="2" style="width: 80px;">C_SIZE</td> </tr> <tr> <td></td> <td style="width: 40px;">CRC</td> <td></td> <td></td> </tr> </table> <p>(High capacity)</p> <table border="1" style="margin-left: 20px;"> <tr> <td style="width: 10px;">127</td> <td style="width: 40px;">TAAC</td> <td style="width: 40px;">NSAC</td> <td style="width: 40px;">TRAN_SPEED</td> </tr> <tr> <td style="width: 10px;">63</td> <td style="width: 40px;">CCC</td> <td colspan="2" style="width: 80px;">C_SIZE</td> </tr> <tr> <td></td> <td style="width: 40px;">CRC</td> <td></td> <td></td> </tr> </table> <p>(Std capacity)</p> <div style="margin-left: 20px; border: 1px solid gray; padding: 5px; background-color: #f0f0f0;"> <p>Examples</p> <p>0x400E0032 0x5B590000 0x1E5C7F80 0x0A4040DE</p> <p>0x00260032 0x5F5A83C9 0x3EFBCFFF 0x928040CA</p> </div>	127	TAAC	NSAC	TRAN_SPEED	63	CCC	C_SIZE			CRC			127	TAAC	NSAC	TRAN_SPEED	63	CCC	C_SIZE			CRC		
127	TAAC	NSAC	TRAN_SPEED																						
63	CCC	C_SIZE																							
	CRC																								
127	TAAC	NSAC	TRAN_SPEED																						
63	CCC	C_SIZE																							
	CRC																								

Figure 12-5 Command responses (SD card)

Command	Response
GO_IDLE_STATE Fig 15-6 (1)	No response
SEND_OP_COND Fig 15-6 (4)	<p>Card power up status May not be 1 on initial reading(s)</p> <p>1 Reserved 0x00 7 bits</p> <p>VDD Voltage Window 0xFF8000 24 bits</p> <p>OCR</p>
ALL_SEND_CID Fig 15-6 (5)	<p>127 MID OID</p> <p>PNM</p> <p>63 PRV PSN</p> <p>MDT CRC</p> <p>MID = Manufacturer ID = 0x1E OID = OEM/Application ID = 0xFFFF PNM = Product name = 0x4D4D43202020 = "MMC " PRV = Product revision = 0x10 = 1.0 PSN = Product serial number = 0x5E6021BA MDT = Manufacturing date = 0x5B</p> <p>Example 0x1EFFFF4D 0x4D432020 0x20105E60 0x21BA5B7E</p>
SEND_CSD Fig 15-6 (6)	<p>127 TAAC NSAC TRAN_SPEED</p> <p>CCC C_SIZE</p> <p>63 CRC</p> <p>Examples 0x902F002A 0x1F5A83C7 0x6DB79FFF 0x9680000E</p>

Figure 12-6 Command responses (MMC card)

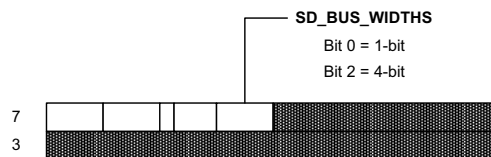

Figure 12-7 SD SCR register

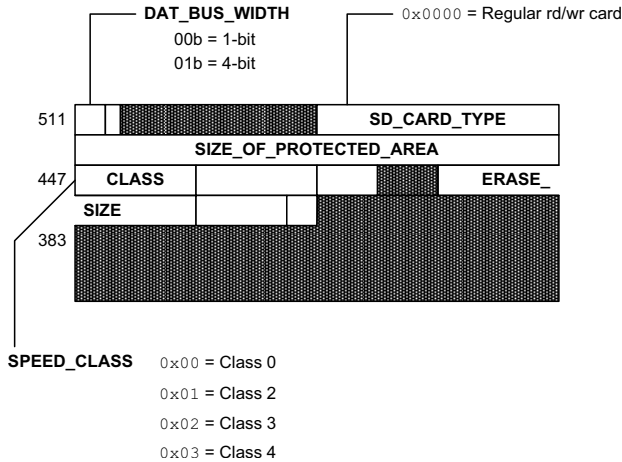

Figure 12-8 SD status

12-2-3 SD/MMC CARDMODE BSP OVERVIEW

A BSP is required so that the SD/MMC cardmode driver will work on a particular system. The functions shown in the table below must be implemented. Please refer to section C-5 “SD/MMC Cardmode BSP” on page 425 for the details about implementing your own BSP.

Function	Description
FSDev_SD_Card_BSP_Open()	Open (initialize) SD/MMC card interface.
FSDev_SD_Card_BSP_Close()	Close (uninitialize) SD/MMC card interface.
FSDev_SD_Card_BSP_Lock()	Acquire SD/MMC card bus lock.
FSDev_SD_Card_BSP_Unlock()	Release SD/MMC card bus lock.
FSDev_SD_Card_BSP_CmdStart()	Start a command.
FSDev_SD_Card_BSP_CmdWaitEnd()	Wait for a command to end and get response.
FSDev_SD_Card_BSP_CmdDataRd()	Read data following command.
FSDev_SD_Card_BSP_CmdDataWr()	Write data following command.
FSDev_SD_Card_BSP_GetBlkCntMax()	Get max block count.
FSDev_SD_Card_BSP_GetBusWidthMax()	Get maximum bus width, in bits.
FSDev_SD_Card_BSP_SetBusWidth()	Set bus width.
FSDev_SD_Card_BSP_SetClkFreq()	Set clock frequency.

Function	Description
FSDev_SD_Card_BSP_SetTimeoutData()	Set data timeout.
FSDev_SD_Card_BSP_SetTimeoutResp()	Set response timeout

Table 12-3 SD/MMC cardmode BSP functions

The `Open()/Close()` functions are called upon open/close or medium change; these calls are always matched. The status and information functions (`GetBlkCntMax()`, `GetBusWidthMax()`, `SetBusWidth()`, `SetClkFreq()`, `SetTimeoutData()`, `SetTimeoutResp()`) help configure the new card upon insertion. `Lock()` and `Unlock()` surround all card accesses.

The remaining functions (`CmdStart()`, `CmdWaitEnd()`, `CmdDataRd()`, `CmdDataWr()`) constitute the command execution state machine (see Figure 12-9). A return error from one of the functions will abort the state machine, so the requisite considerations, such as preparing for the next command or preventing further interrupts, must be first handled.

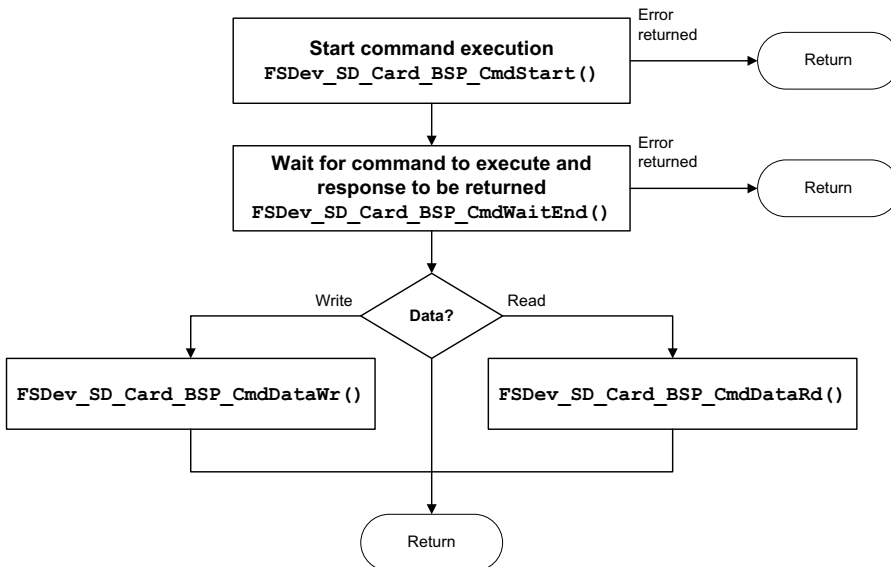

Figure 12-9 Command execution

12-3 USING THE SD/MMC SPI DRIVER

To use the SD/MMC SPI driver, five files, in addition to the generic file system files, must be included in the build:

- `fs_dev_sd.c`
- `fs_dev_sd.h`
- `fs_dev_sd_spi.c`
- `fs_dev_sd_spi.h`
- `fs_dev_sd_spi_bsp.c`

The file `fs_dev_sd_spi.h` must also be `#included` in any application or header files that directly reference the driver (for example, by registering the device driver). The following directories must be on the project include path:

- `\Micrium\Software\uC-FS\Dev\SD`
- `\Micrium\Software\uC-FS\Dev\SD\SPI`

A single SD/MMC volume is opened as shown in Listing 12-2. The file system initialization (`FS_Init()`) function must have previously been called.

ROM/RAM characteristics and performance benchmarks of the SD/MMC driver can be found in section 9-1-1 “Driver Characterization” on page 113. The SD/MMC driver also provides interface functions to get low-level card information and read the Card ID and Card-Specific Data registers (see section A-12 “FAT System Driver Functions” on page 386).

```
FS_ERR App_FS_AddSD_SPI (void)
{
    FS_ERR    err;

    FS_DrvAdd((FS_DEV_API *)&FSDev_SD_SPI,      /* (1) */
              (FS_ERR    *)&err);
    if ((err != FS_ERR_NONE) && (err != FS_ERR_DEV_DRV_ALREADY_ADDED)) {
        return (DEF_FAIL);
    }
}
```

```

/* (2) */
FSDev_Open((CPU_CHAR *)"sd:0:",
           (void *) 0,
           (FS_ERR *)&err);
/* (a) */
/* (b) */

switch (err) {
case FS_ERR_NONE:
    break;

case FS_ERR_DEV:
case FS_ERR_DEV_IO:
case FS_ERR_DEV_TIMEOUT:
case FS_ERR_DEV_NOT_PRESENT:
    return (DEF_FAIL);
default:
    return (DEF_FAIL);
}

/* (3) */
FSVol_Open((CPU_CHAR *)"sd:0:",
           (CPU_CHAR *)"sd:0:",
           (FS_PARTITION_NBR ) 0,
           (FS_ERR *)&err);
/* (a) */
/* (b) */
/* (c) */

switch (err) {
case FS_ERR_NONE:
    APP_TRACE_DBG((" ...opened volume (mounted).\r\n"));
    break;
case FS_ERR_DEV:
case FS_ERR_DEV_IO:
case FS_ERR_DEV_TIMEOUT:
case FS_ERR_DEV_NOT_PRESENT:
case FS_ERR_PARTITION_NOT_FOUND:
    APP_TRACE_DBG((" ...opened device (unmounted).\r\n"));
    return (DEF_FAIL);
default:
    APP_TRACE_DBG((" ...opening volume failed w/err = %d.\r\n\r\n", err));
    return (DEF_FAIL);
}
return (DEF_OK);
}
}

```

Listing 12-2 Opening a SD/MMC device volume

L12-2(1) Register the SD/MMC SPI device driver `FSDev_SD_SPI`.

L12-2(2) **FSDev_Open()** opens/initializes a file system device. The parameters are the device name (1a) and a pointer to a device driver-specific configuration structure (1b). The device name (1a) is composed of a device driver name (“sd”), a single colon, an ASCII-formatted integer (the unit number) and another colon. Since the SD/MMC SPI driver requires no configuration, the configuration structure (1b) should be passed a NULL pointer.

Since SD/MMC are often removable media, it is possible for the device to not be present when **FSDev_Open()** is called. The device will still be added to the file system and a volume opened on the (not yet present) device. When the volume is later accessed, the file system will attempt to refresh the device information and detect a file system (see section 5-2 “Using Devices” on page 69 for more information).

L12-2(3) **FSVol_Open()** opens/mounts a volume. The parameters are the volume name (2a), the device name (2b) and the partition that will be opened (2c). There is no restriction on the volume name (2a); however, it is typical to give the volume the same name as the underlying device. If the default partition is to be opened, or if the device is not partitioned, then the partition number (2c) should be zero.

If the SD/MMC initialization succeeds, the file system will produce the trace output as shown in Figure 12-10 (if a sufficiently high trace level is configured). See section E-9 “Trace Configuration” on page 507 about configuring the trace level.

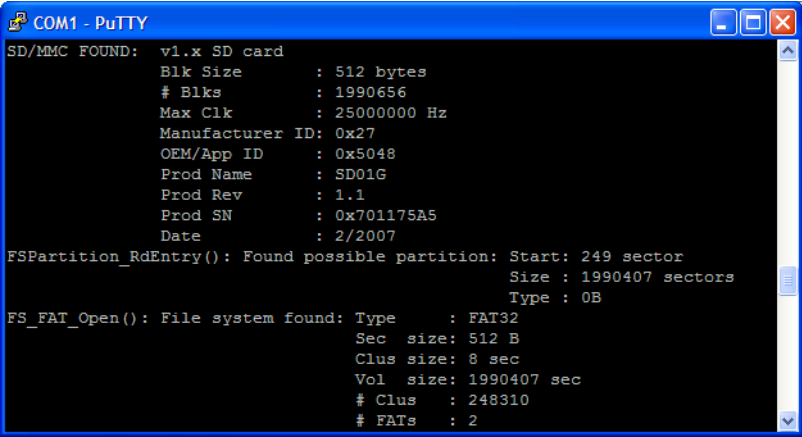

```
COM1 - PuTTY
SD/MMC FOUND: v1.x SD card
Blk Size      : 512 bytes
# Blks       : 1990656
Max Clk      : 25000000 Hz
Manufacturer ID: 0x27
OEM/App ID   : 0x5048
Prod Name    : SD01G
Prod Rev     : 1.1
Prod SN      : 0x701175A5
Date        : 2/2007

FSPartition_RdEntry(): Found possible partition: Start: 249 sector
Size : 1990407 sectors
Type : 0B

FS_FAT_Open(): File system found: Type      : FAT32
Sec size: 512 B
Clus size: 8 sec
Vol size: 1990407 sec
# Clus   : 248310
# FATs   : 2
```

Figure 12-10 SD/MMC detection trace output

12-3-1 SD/MMC SPI COMMUNICATION

SPI is a simple protocol supported by peripherals commonly built-in on CPUs. Moreover, since the communication can easily be accomplished by software control of GPIO pins (“software SPI” or “bit-banging”), a SD/MMC card can be connected to almost any platform. In SPI mode, seven pins on the SD/MMC device are used, with the functions listed in Table 12-4. As with any SPI device, four signals are used to communicate with the host (CS, DataIn, CLK and DataOut). Some card holders contain circuitry for card detect and write protect indicators, which the MCU/MPU may also monitor.

Pin	Name	Type	Description
1	CS	I	Chip Select
2	DataIn	I	Host-to-card commands and data
3	Vss1	S	Supply voltage ground
4	VDD	S	Supply voltage
5	CLK	I	Clock
6	VSS2	S	Supply voltage ground
7	DataOut	O	Card-to-host data and status

Table 12-4 SD/MMC pinout (SPI mode)

The four signals connecting the host (or master) and card (also known as the slave) are named variously in different manuals and documents. The DataIn pin of the card is also known as MOSI (Master Out Slave In); it is the data output of the host CPU. Similarly, the DataOut pin of the card is also known as MISO (Master In Slave Out); it is the data input of the host CPU. The CS and CLK pins (also known as SSEL and SCK) are the chip select and clock pins. The host selects the slave by asserting CS, potentially allowing it to choose a single peripheral among several that are sharing the bus (i.e., by sharing the CLK, MOSI and MISO signals).

When a card is first connected to the host (at card power-on), it is in the ‘inactive’ state, awaiting a `GO_IDLE_STATE` command to start the initialization process. The card will enter SPI mode (rather than card mode) because the driver holds the CS signal low while executing the `GO_IDLE_STATE` command. The card now in the ‘idle’ state moves through the ‘ready’ (as long as it supports the voltage range specified by the host) before ending up in ‘standby’. It can now get selected by the host (using the chip select) for data transfers. Figure 15-5 flowcharts this procedure.

12-3-2 SD/MMC SPI COMMUNICATION DEBUGGING

The SD/MMC SPI driver accesses the hardware through a port (SPI BSP) as described in section C-6 “SD/MMC SPI mode BSP” on page 452. A new BSP developed according to MCU/MPU documentation or by example must be verified step-by-step until flawless operation is achieved:

- 1 Initialization. Initialization must succeed.
- 2 Read data. Data must be read from card, in both single- and multiple-block transactions.
- 3 Write data. Data must be written to the card, in both single and multiple-block transactions, and subsequently verified (by reading the modified sectors and comparing to the intended contents).

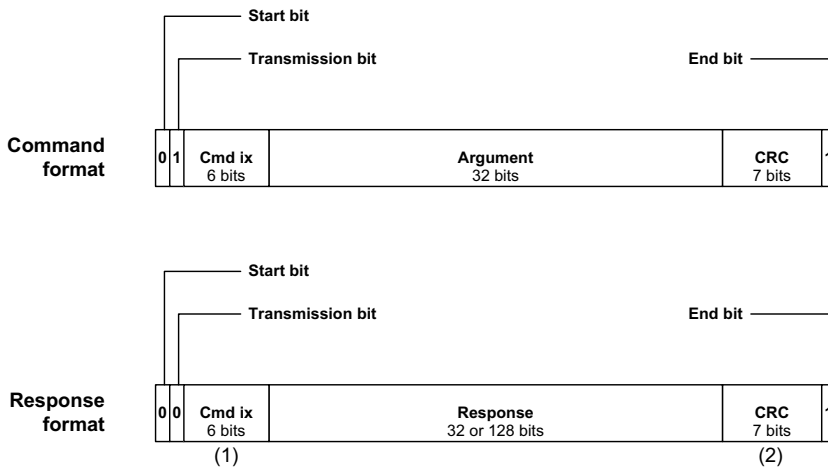

Figure 12-11 SD/MMC SPI mode communication sequence

- F12-11(1) When no data is being transmitted, DataOut line is held high.
- F12-11(2) During busy signaling, DataOut line is held low.
- F12-11(3) The CRC is the 16-bit CCITT CRC. By default, this is optional and dummy bytes may be transmitted instead. The card only checks the CRC if `CRC_ON_OFF` has been executed.

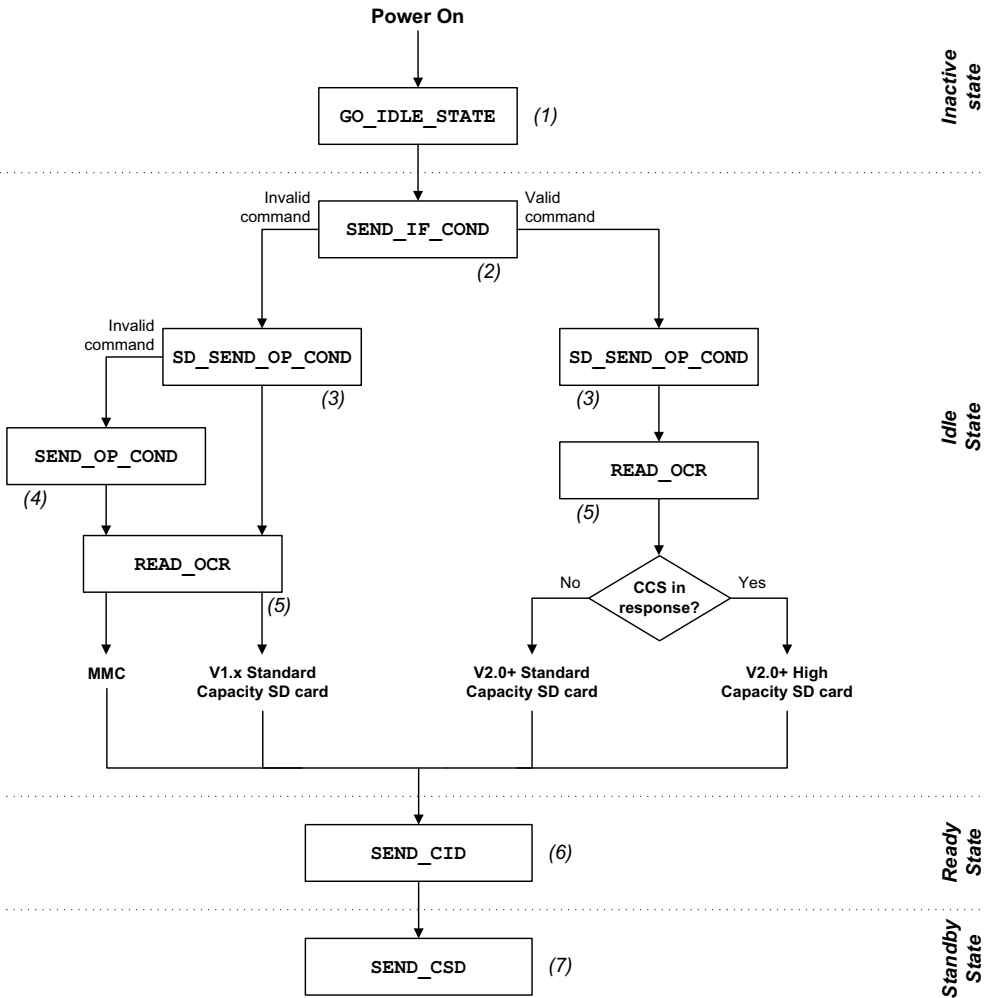

Figure 12-13 Simplified SD/MMC SPI mode initialization and state transitions

The initialization process reveals that commands can be executed and proper responses are returned. The command responses in SPI mode are identical to those in cardmode (see Figure 12-5 and Figure 12-6), except each is preceded by a R1 status byte. Obvious errors, such as improper initialization or failed chip select manipulation, will typically be caught here. More subtle conditions may appear intermittently during reading or writing.

12-3-3 SD/MMC SPI BSP OVERVIEW

An SPI BSP is required so that the SD/MMC SPI driver will work on a particular system. For more information about these functions, see section C-7 “SPI BSP” on page 453.

Function	Description
FSDev_SD_SPI_BSP_SPI_Open()	Open (initialize) SPI
FSDev_SD_SPI_BSP_SPI_Close()	Close (uninitialize) SPI
FSDev_SD_SPI_BSP_SPI_Lock()	Acquire SPI lock
FSDev_SD_SPI_BSP_SPI_Unlock()	Release SPI lock
FSDev_SD_SPI_BSP_SPI_Rd()	Read from SPI
FSDev_SD_SPI_BSP_SPI_Wr()	Write to SPI
FSDev_SD_SPI_BSP_SPI_ChipSelEn()	Enable chip select
FSDev_SD_SPI_BSP_SPI_ChipSelDis()	Disable chip select
FSDev_SD_SPI_BSP_SPI_SetClkFreq()	Set SPI clock frequency

Table 12-5 SD/MMC SPI BSP functions

NAND Flash Driver

Standard storage media (such as hard drives) and managed flash-based devices (such as SD/MMC and CF cards) require relatively simple drivers that convert the file system's request to read or write a sector into a hardware transaction. In comparison, the driver for a raw NAND flash is more complicated. Flash is divided into large blocks (often 16-kB to 512-kB); however, the high-level software (for example a FAT file system) expects to read or write small sectors (512-bytes to 4096-bytes) atomically. The driver implements a NAND block abstraction to conceal the device geometry from the file system. To aggravate matters, each block may be subjected to a finite number of erases. A wear-leveling algorithm must be employed so that each block is used equally. All these mechanisms are grouped in the main layer of the driver, called the NAND translation layer.

The NAND flash driver included in $\mu\text{C}/\text{FS}$ has the following features:

Dynamic wear-leveling: Using logical block addressing, the driver is able to change the physical location of written data on the NAND flash, so that a single memory location does not wear early while other locations are not used.

Fail-safe to unexpected power-loss: The NAND flash driver was designed so that write transactions are atomic. After an unexpected power-down, the NAND flash's low-level format will still be consistent, the device will be remounted as if the transaction never occurred.

Scalable: Various configuration options (see section 13-3-1 "Translation Layer Configuration" on page 171) are available for you to adjust the memory footprint; the speed and the wear-leveling performance of the driver.

Flexible controller layer: You can provide your own implementation of the controller layer to take advantage of hardware peripherals and reduce CPU usage. However, a generic controller driver that is compatible with most parallel NAND flash devices and micro-controllers is provided.

Error correction codes (ECC) management: Error correction codes are used to eliminate the bit read errors typical to NAND flash. It is easy to provide a software implementation of an ECC scheme or to interface to a hardware engine for each device used. It is then possible to configure the size of the codewords and the level of protection required to suit the needs of your application.

Wide support for different NAND flashes: Most NAND flash memories are compatible with the driver, including large pages, small pages, SLC and MLC (single and multiple level cells) flash memory. Please contact Micrium to inquire about μ C/FS's compatibility with specific NAND devices.

13-1 GETTING STARTED

The following section shows an example on how to get started in a typical case comprising the following:

- The generic controller layer implementation (included with the NAND driver)
- The 1-bit software ECC implementation (included with the NAND driver)
- The static part layer implementation (included with the NAND driver)
- Your BSP layer implementation to adapt the driver to your specific platform

In case you need additional information and details regarding the different layers, please refer to the section 13-2 “Architecture Overview” on page 167.

To use the NAND driver, you must include the following ten files in the build, in addition to the generic file system files:

- `fs_dev_nand.c` (\Micrium\Software\uC-FS\Dev\NAND.)
- `fs_dev_nand.h` (\Micrium\Software\uC-FS\Dev\NAND.)
- `fs_dev_nand_ctrlr_gen.c` (\Micrium\Software\uC-FS\Dev\NAND\Ctrlr)
- `fs_dev_nand_ctrlr_gen.h` (\Micrium\Software\uC-FS\Dev\NAND\Ctrlr)

- `fs_dev_nand_part_static.c` (\Micrium\Software\uC-FS\Dev\NAND\Part)
- `fs_dev_nand_part_static.h` (\Micrium\Software\uC-FS\Dev\NAND\Part)
- `ecc_hamming.c` (\Micrium\Software\uC-CRC\Source)
- `ecc_hamming.h` (\Micrium\Software\uC-CRC\Source)
- `ecc.h` (\Micrium\Software\uC-CRC\Source)
- Your BSP layer implementation (derived from `fs_dev_nand_ctrlr_gen_bsp.c` in \Micrium\Software\uC-FS\Dev\NAND\BSP\Template).

The example in Listing 13-1 shows how to open a single NAND volume. The file system initialization function (`FS_Init()`) must have previously been called.

```
#include <ecc_hamming.h>
#include <fs.h>
#include <fs_err.h>
#include <fs_vol.h>
#include <fs_dev_nand.h>
#include <fs_dev_nand_ctrlr_gen.h>
#include <fs_dev_nand_ctrlr_gen_soft_ecc.h>
#include <fs_dev_nand_part_static.h>

FS_NAND_FREE_SPARE_MAP App_SpareMap[2] = { { 1, 63},
                                             {-1, -1} };

static CPU_BOOLEAN App_FS_AddNAND (void)
{
    /* (1) */
    FS_NAND_CFG          cfg_nand      = FS_NAND_DfltCfg;
    FS_NAND_CTRLR_GENERIC_CFG  cfg_ctrlr = FS_NAND_CtrlrGen_DfltCfg;
    FS_NAND_CTRLR_GEN_SOFT_ECC_CFG  cfg_soft_ecc = FS_NAND_CtrlrGen_SoftEcc_DfltCfg;
    FS_NAND_PART_STATIC_CFG  cfg_part   = FS_NAND_PartStatic_DfltCfg;
    FS_ERR                  err;
    FS_DevDrvAdd((FS_DEV_API *)&FS_NAND, /* (2) */
                &err);
    if ((err != FS_ERR_NONE) &&
        (err != FS_ERR_DEV_DRV_ALREADY_ADDED)) {
        APP_TRACE_DBG((" ...could not add driver w/err = %d\r\n\r\n", err));
        return (DEF_FAIL);
    }
}
```

```

                                                    /* (3) */
cfg_part.BlkCnt          = 2048;
cfg_part.PgPerBlk       = 64;
cfg_part.PgSize         = 2048;
cfg_part.SpareSize      = 64;
cfg_part.SupportsRndPgPgm = DEF_NO;
cfg_part.NbrPgmPerPg    = 4;
cfg_part.BusWidth       = 8;
cfg_part.ECC_NbrCorrBits = 1;
cfg_part.ECC_CodewordSize = 512 + 16;
cfg_part.DefectMarkType = DEFECT_SPARE_L_1_PG_1_OR_N_ALL_0;
cfg_part.MaxBadBlkCnt   = 40;
cfg_part.MaxBlkErase    = 100000;
cfg_part.FreeSpareMap   = &spare_map[0];

                                                    /* (4) */
cfg_ctrlr.CtrlrExt      = &FS_NAND_CtrlrGen_SoftECC;
cfg_ctrlr.CtrlrExtCfg = &soft_ecc_cfg;

                                                    /* (5) */
cfg_soft_ecc.ECC_ModulePtr = (ECC_CALC *)&Hamming_ECC;

                                                    /* (6) */
cfg_nand.BSPPtr        = (void *)&FS_NAND_BSP_SAM9M10;
cfg_nand.CtrlrPtr      = (FS_NAND_CTRLR_API *)&FS_NAND_CtrlrGeneric;
cfg_nand.CtrlrCfgPtr   = &cfg_ctrlr;
cfg_nand.PartPtr       = (FS_NAND_PART_API *)&FS_NAND_PartStatic;
cfg_nand.PartCfgPtr    = &cfg_part;
cfg_nand.SecSize       = 512;
cfg_nand.BlkCnt        = 2038u;
cfg_nand.BlkIxFirst   = 10u;
cfg_nand.UB_CntMax     = 10u;
cfg_nand.RUB_MaxAssoc  = 2u;
cfg_nand.AvailBlkTblEntryCntMax = 10u;

                                                    /* (7) */
FSDev_Open(          "nand:0:",          /* (a) */
              (void *)&cfg_nand,        /* (b) */
              &err);

switch (err) {
case FS_ERR_NONE:
APP_TRACE_DBG((" ...opened device.\r\n"));
break;

```

```

        case FS_ERR_DEV_INVALID_LOW_FMT:
        case FS_ERR_DEV_INCOMPATIBLE_LOW_PARAMS:
        case FS_ERR_DEV_CORRUPT_LOW_FMT:
            APP_TRACE_DBG(("    ...opened device (not low-level formatted).\r\n"));
    #if (FS_CFG_RD_ONLY_EN == DEF_ENABLED)
        FS_NAND_LowFmt("nand:0:", &err);          /* (8) */
        if (err != FS_ERR_NONE) {
            APP_TRACE_DBG(("    ...low-level format failed.\r\n"));
            return 0;
        }
    #else
        APP_TRACE_DBG(("    ...opening device failed w/err = %d.\r\n\r\n", err));
        return 0;
    #endif

        break;

        case FS_ERR_DEV_ALREADY_OPEN:
            break;

        case FS_ERR_DEV:
        case FS_ERR_DEV_IO:
        case FS_ERR_DEV_TIMEOUT:
        case FS_ERR_DEV_NOT_PRESENT:
        default:
            APP_TRACE_DBG(("    ...opening device failed w/err = %d.\r\n\r\n", err));
            return (DEF_FAIL);
    }

    /* (9) */
    FSVol_Open("nand:0:",          /* (a) */
              "nand:0:",          /* (b) */
              0,                  /* (c) */
              &err);*/

    switch (err) {
        case FS_ERR_NONE:
            APP_TRACE_DBG(("    ...opened volume (mounted).\r\n"));
            break;

        case FS_ERR_PARTITION_NOT_FOUND:          /* Volume error. */
            APP_TRACE_DBG(("    ...opened device (not formatted).\r\n"));
    #if (FS_CFG_RD_ONLY_EN == DEF_DISABLED)
        FSVol_Fmt("nand:0:", (void *)0, &err); /* (10) */
        if (err != FS_ERR_NONE) {
            APP_TRACE_DBG(("    ...format failed.\r\n"));
            return (DEF_FAIL);
        }
    #else
        APP_TRACE_DBG(("    ...opening device failed w/err = %d.\r\n\r\n", err));
        return 0;
    #endif

        break;

```

```
case FS_ERR_DEV:                                /* Device error.          */
case FS_ERR_DEV_IO:
case FS_ERR_DEV_TIMEOUT:
case FS_ERR_DEV_NOT_PRESENT:
    APP_TRACE_DBG(("    ...opened volume (unmounted).\r\n"));
    return (DEF_FAIL);

default:
    APP_TRACE_DBG(("    ...opening volume failed w/err = %d.\r\n\r\n", err));
    return (DEF_FAIL);
}

return (DEF_OK);
}
```

Listing 13-1 **Opening a NAND device volume**

- L13-1(1) Declare and initialize configuration structures. Structures should be initialized to allow for forward compatibility in case some new fields in those structures are added in future μ C/FS versions.
- L13-1(2) Register the NAND device driver **FS_NAND**.
- L13-1(3) The NAND part layer configuration structure should be initialized. For more information about these parameters, see section “Statically configured part layer” on page 181.
- L13-1(4) The NAND controller layer configuration structure should be initialized. For more information about these parameters, see section 13-4-1 “Generic Controller Layer Implementation” on page 179. Please note that you might need to use a different controller layer. If this is the case, the configuration might be different (see section 13-4 “Controller Layer” on page 178).
- L13-1(5) The NAND generic controller software ECC extension should be initialized. For more information about these parameters, see section “Generic Controller Extension Layer” on page 180. Please note that if you are using a different controller layer implementation, there probably won’t be a controller extension layer. Also, if using the generic controller, you might need to use a different extension. Refer to section “Generic Controller Extension Layer” on page 180 for a list of available controller extensions.

-
- L13-1(6) The NAND translation layer structure should be initialized. For more information about these parameters, see section 13-3-1 “Translation Layer Configuration” on page 171.
- L13-1(7) **FSDev_Open()** opens/initializes a file system device. The parameters are the device name (a) and a pointer to a device driver-specific configuration structure (b). The device name (a) is composed of a device driver name (“nand”), a single colon, an ASCII-formatted integer (the unit number) and another colon.
- L13-1(8) **FS_NAND_LowFmt()** low-level formats a NAND. If the NAND has never been used with μ C/FS, it must be low-level formatted before being used. Low-level formatting will create and initialize the low-level driver metadata on the device.
- L13-1(9) **FSVol_Open()** opens/mounts a volume. The parameters are the volume name (a), the device name (b) and the index of the partition that will be opened (c). There is no restriction on the volume name (a); however, it is typical to give the volume the same name as the underlying device. If the default partition is to be opened, or if the device is not partition, then the partition number (c) should be 0.
- L13-1(10) **FSVol_Fmt()** formats a file system device. If the NAND has just been low-level formatted, there will be no file system on the corresponding volume after it is opened (it will be unformatted). The volume must be formatted before files can be created or accessed.

If the NAND initialization succeeds, the file system traces (if a sufficiently high trace level is configured) will produce an output similar to Listing 13-1. See section E-9 “Trace Configuration” on page 507 about configuring the trace level.

```
=====
=                               FS INITIALIZATION                               =
=====
Initializing FS...
=====
    Adding/opening NAND volume "nand:0:"...
NAND Ctrlr Gen: found NAND manif id=2c, dev id=aa.
FS_NAND_Open(): Using default blk cnt (all blocks): 2048.
FS_NAND_Open(): Default number of entries in avail blk tbl.
NAND FLASH FOUND: Name      : "nand:0:"
                   Sec Size : 2048 bytes
                   Size     : 127360 sectors
                   Update blks: 10
FS_NAND_LowMountHandler(): Low level mount succeeded.
    ...opened device.
FSPartition_RdEntry(): Found possible partition: Start: 0 sector
                               Size : 0 sectors
                               Type : 00
FS_FAT_VolOpen(): File system found: Type      : FAT16
                               Sec size: 2048 B
                               Clus size: 4 sec
                               Vol size: 127360 sec
                               # Clus  : 31822
                               # FATs  : 2
    ...opened volume (mounted).
...init succeeded.
=====
=====
```

Listing 13-2 NAND detection trace output

HANDLING DIFFERENT USE-CASES

If the above example does not apply to your situation, we strongly recommend you read the sections about the different layers. This will help you determine if other existing implementations are suitable for you, or if you need to develop your own implementation of some of those layers.

13-2 ARCHITECTURE OVERVIEW

The NAND driver comprises multiple layers, as depicted in Figure 13-1.

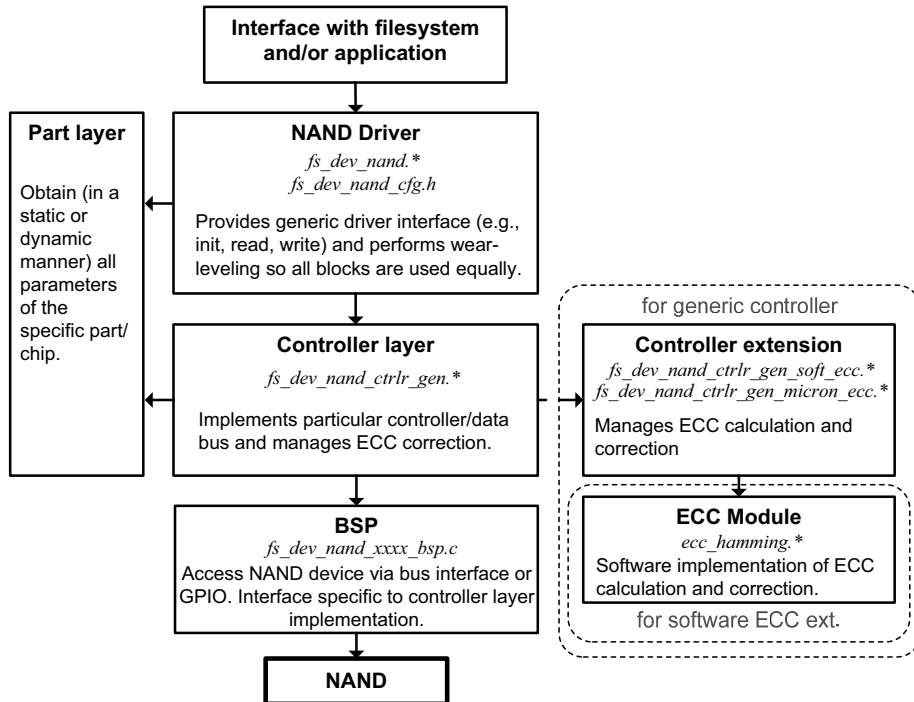

Figure 13-1 NAND driver architecture

The generic NAND translation layer provides sector abstraction and performs wear-leveling (to ensure all blocks are used equally).

The controller layer driver interfaces with the NAND translation layer at the physical level (block erase, sector write/read, spare area write/read operations). The controller layer is also responsible for the placement of sectors and metadata within a NAND page. Interfacing at this level allows more flexibility: if your micro-controller has dedicated hardware like an ECC calculation engine or a NAND flash memory controller, you can interface directly with it by providing your own controller layer implementation instead of using the generic implementation (see section 13-4-1 “Generic Controller Layer Implementation” on page 179) included with the NAND driver.

The controller extension layer is specific to the generic controller implementation (`fs_dev_nand_ctrlr_gen.*`). It provides an interface that allows different types of ECC calculation and correction schemes to be used while avoiding duplication of the generic controller code. Implementations for software ECC and some Micron on-chip ECC devices (including MT29F1G08ABADA) are provided with the NAND flash driver.

The BSP layer will implement code that depends on your platform and application for the specific controller layer implementation chosen. In most cases, you will need to develop your own implementation of the BSP layer.

The part layer is meant to provide the specifics for each part/chip you use in your design to the controller and NAND translation layers. This layer implementation will typically be chosen from the implementations included with the NAND driver. This implementation can either rely on statically defined parameters or values read directly from the device (for an ONFI compliant part).

The ECC layer provides code calculation and error correction functions. For performance reasons, only a 1-bit ECC software module based on Hamming codes is provided (part of the μ C/CRC product bundled with μ C/FS). If a more robust ECC correction scheme is required, it is strongly recommended to use hardware engines. Since the ECC-specific code of the generic controller driver is implemented in generic controller extension modules, it can easily be adapted if the micro-controller or NAND flash device can handle ECC automatically.

13-3 NAND TRANSLATION LAYER

The NAND translation layer is the main layer of the driver, implemented by the files `fs_dev_nand.c` and `fs_dev_nand.h`. This layer contains most of the algorithms necessary to overcome the following limitations of NAND flash technology:

- Write operations can only change a bit state from '1' to '0'. Only erase operations can revert the bit state, from '0' to '1'.
- Erase operations are only performed on large sections of the memory called blocks (typically between 16 kB and 512 kB).

- Write operations are performed on a sub-section of a block, called a page (typically between 512 and 8192 octets).
- Some devices support partial page programming (splitting the operation to write a full page into multiple operations that each write a sub-section of the page). Other devices can only have their pages written in a single operation before they are erased.
- Some devices must write the pages of a block in a sequential manner (page 0, page 1, page 2, etc.).
- Blocks can only be erased a limited number of times (typically 10k to 100k) before the integrity of the memory is compromised.
- Some device blocks can't be used reliably and are considered bad blocks. These blocks are either marked at the factory or become bad during the device's life.
- Electric disturbance can cause read errors. An error correction mechanism must be used to decrease the bit error rate.

The role of the translation layer is to translate those NAND flash specific requirements into a disk interface, based on sector access. This disk interface allows the NAND driver to be used with traditional sector-based file systems like FAT, which is used by $\mu\text{C}/\text{FS}$.

The translation layer implementation provided with the NAND driver is inspired by the KAST (K-Associative Sector Translation) as proposed by Cho (see Appendix G, "Bibliography" on page 535).

In the provided implementation, three types of blocks are present on the device. The data blocks typically occupy the major portion of the storage space. Data blocks are used to contain the data written to the device by the application or file system. A mapping between the logical addresses of the blocks and their physical locations is used to enable wear-leveling.

This mapping, as well as other metadata, is contained in metadata blocks. Typically, only one block is used to store metadata. This block is also moved around for wear-leveling reasons.

The third type of blocks are update blocks. All data written on the device must first be written through update blocks. Under specific circumstances (including an update block becoming full), the contents of an update block are folded onto data blocks. The folding operation roughly consists of three steps. The first step is to find an unused block and erase it. Secondly, the contents of the corresponding data block must be merged with the more recent, but incomplete data contained in the update block. This merged data is written in the recently-erased block. Once this operation is complete, metadata must be updated: the old data block and the update block are marked as free to erase and use, and the block mapping must be updated to point to the new data block.

In this implementation, it is possible to specify how many different data blocks pointed to by a single update block. This specification is called maximum associativity (see the configuration field `.RUB_MaxAssoc` in section “Device configuration” on page 175). If this value is greater than one, the merge operation must be performed for each data block associated with the update block being folded.

Each update block can be of one of the two sub-types: random update blocks (RUBs) and sequential update blocks (SUBs). Sequential update blocks can only refer to a single data block (associativity is always 1). Also, they must use the same exact layout as a data block (i.e. logical sector 0 written at physical sector 0, logical sector 1 written at physical sector 1, etc.). The advantage of SUBs is that they have a much lower merge cost. They can be converted into data blocks in-place by copying missing sectors from the associated data block and updating some metadata. Random update blocks, on the other hand, can contain sectors from multiple data blocks. Those sectors can be written at any location in the RUB since it contains additional metadata to map each sector to an appropriate location in a data block, resulting in an increased merge cost but allowing for better wear-leveling since it leads to better block usage in the case of random writes.

Another important functionality of the translation layer is to keep track of the number of erase operations performed on each block. The erase count is critical for two reasons. First, the erase count can be used to efficiently drive the wear-leveling algorithm, allowing seldom erased blocks to be preferred over frequently erased blocks, when a new block is required. Secondly, the erase count allows the translation layer to detect the blocks that have reached their erase limit.

Since the erase count information is stored in each block, each erase count must be backed-up somewhere else in the device prior to erasing a block. Blocks that have their erase count backed-up are called available blocks. When the translation layer needs a new block, it will always be taken from the available blocks table to make sure its erase count is not lost in the case of an unexpected power-down.

All this functionality is embedded within the translation layer. Using the software itself does not require a deep understanding of the mechanisms as they are all abstracted into a simpler, easier to understand disk interface. However, understanding the internals can be useful to efficiently configure the translation layer.

13-3-1 TRANSLATION LAYER CONFIGURATION

The configuration of the NAND translation layer (`fs_dev_nand.*`) must be done through two mechanisms. First, you need to specify driver-wide configuration options in the configuration file (`fs_dev_nand_cfg.h`). Then, you need to configure the device-specific options passed to the function `FSDev_Open()` through a structure pointer. You need to call `FSDev_Open()` for each device you want to access and provide a proper device-specific configuration for each of them.

DRIVER CONFIGURATION FILE

The driver configuration file for the NAND translation layer is `fs_dev_nand_cfg.h`. A template for this file is located in the following path:

```
\Micrium\Software\uC-FS\Dev\NAND\Cfg\Template\
```

The driver configuration `#defines` available in the configuration file are listed below.

FS_NAND_CFG_AUTO_SYNC_EN

This `#define` determines if, for each operation on the device (i.e. each call to the device's API), the metadata should be synchronized. Synchronizing at the end of each operation is safer; it ensures the device can be remounted and appear exactly as it should. Disabling automatic synchronization can result in a large write speed increase, as the metadata won't be committed automatically, unless triggered by the application. If a power down occurs between a device operation and a sync operation, the device will appear as it was in a prior state when remounted. Device synchronization can be forced with a call to `FSDev_Sync()`.

Note that using large write buffers will reduce the metadata synchronization performance hit, as fewer calls to the device API will be needed.

FS_NAND_CFG_UPDATE_BLK_META_CACHE_EN

This `#define` determines if, for each update block, the metadata will be cached. Enabling this will allow searching for a specific updated sector through data in RAM instead of accessing the device, which would require additional read page operations.

More RAM will be consumed if this option is enabled, but write/read speed will be improved.

RAM usage = $\langle \text{Nbr update blks} \rangle \times$
 $(\log_2(\langle \text{Max associativity} \rangle) + \log_2(\langle \text{Nbr secs per blk} \rangle)) /$
 8 octets.

The result should be rounded up.

FS_NAND_CFG_DIRTY_MAP_CACHE_EN

This `#define` determines if the dirty blocks map will be cached. With this feature enabled, a copy of the dirty blocks map on the device is cached. It is possible then to determine if the state “dirty” of a block is committed on the device without the need to actually read the device.

With this feature enabled, overall write and read speed should be improved. Also, robustness will be improved for specific cases. However, more RAM will be consumed.

RAM usage = $\langle \text{Nbr of blks on device} \rangle / 8 \text{ octets}$

The result should be rounded up.

FS_NAND_CFG_UPDATE_BLK_TBL_SUBSET_SIZE

This `#define` controls the size of the subsets of sectors pointed by each entry of the update block tables. The value must be a power of 2 (or 0).

If, for example, the value is 4, each time a specific updated sector is requested, the NAND translation layer must search the sector in a group of four sectors. Thus, if the update block metadata cache (`FS_NAND_CFG_UPDATE_BLK_META_CACHE_EN`) is disabled, four sectors must be read from the device to find the requested sector. The four entries will instead be read

from the cache, if it is enabled. If the value is set to 0, the table will be disabled completely, meaning that all sectors of the block might have to be read before the specified sector is found. If the value is 1, the table completely specifies the location of the sector, and thus no search must be performed. In that case, enabling the update block metadata cache will yield no performance benefit.

```
RAM usage = <Nbr update blks> x
            (log2(Nbr secs per blk) - log2(<Subset size>) x
            <Max associativity> /
            8 octets
```

The result should be rounded up.

FS_NAND_CFG_RSVD_AVAIL_BLK_CNT

This `#define` indicates the number of blocks in the available blocks table that are reserved for metadata block folding. Since this operation is critical and must be done before adding blocks to the available blocks table, the driver needs enough reserved blocks to make sure at least one of them is not bad so that the metadata can be folded successfully. When set to 3, probability of the metadata folding operation failing is almost null. This value is sufficient for most applications.

FS_NAND_CFG_MAX_RD_RETRIES

This `#define` indicates the maximum number of retries performed when a read operation fails. It is recommended by most manufacturers to retry reading a page if it fails, as successive read operations might be successful. This number should be at least set to 2 for smooth operation, but might be set higher to improve reliability. Please be aware that a high number of retries will reduce the response time of the system when it tries to read a defective sector.

FS_NAND_CFG_MAX_SUB_PCT

This `#define` indicates the maximum allowed number of sequential update blocks (SUB). This value is set as a percentage of the total number of update blocks. SUBs will improve the performance for large transactions on the file system (ex: copying multi-MB files). Small files or small iterative changes to large files are best handled by RUBs. It is important to note that the translation layer will automatically determine what type of update block is the best depending on the parameters of the transaction itself. This parameter is only to limit the number of update blocks that can be SUBs.

ADVANCED CONFIGURATION OPTIONS

The following configuration `#defines` should be left at their default values. Advanced understanding of the wear-leveling and block abstraction algorithms is necessary to set these configurations.

FS_NAND_CFG_TH_PCT_MERGE_RUB_START_SUB

This `#define` indicates the minimum size (in sectors) of the write operation needed to create a sequential update block (SUB) when a random update block (RUB) already exists. SUBs offer a substantial gain in merge speed when a large quantity of sectors are written sequentially (within a single or multiple write operations). However, if many SUBs are created and merged early, the device will wear faster (less sectors written between block erase operations).

This threshold is set as a percentage (relative to the number of sectors per block).

Set higher than default for better overall wear leveling and lower than default for better overall write speed.

FS_NAND_CFG_TH_PCT_CONVERT_SUB_TO_RUB

This `#define` indicates the minimum size (in sectors) of free space needed in a sequential update block (SUB) to convert it to a random update block (RUB). RUBs have more flexible write rules, at the expense of a longer merge time. If the SUB's usage is over the threshold, the SUB will be merged and a new RUB will be started, instead of performing the conversion from SUB to RUB.

This threshold is set as a percentage (relative to number of sectors per block).

Set higher than default for better overall write speed and lower than default for better overall wear leveling.

To take advantage of this threshold, it must be set higher than the value of `FS_NAND_CFG_TH_PCT_PAD_SUB`. Otherwise, this threshold won't have any effect.

FS_NAND_CFG_TH_PCT_PAD_SUB

This `#define` indicates the maximum size (in sectors) that can be skipped in a sequential update block (SUB). Since each sector of a SUB must be written at a single location (sector physical index == sector logical index), it is possible to allow small gaps in the sequence. Larger gaps are more flexible, and can improve the overall merge speed, at the cost of faster wear, since some sectors are left empty between erase operations.

This threshold is set as a percentage (relative to number of sectors per block).

Set higher than default for better overall write speed and lower than default for better overall wear leveling

FS_NAND_CFG_TH_PCT_MERGE_SUB

This `#define` indicates the maximum size (in sectors) of free space needed in a sequential update block (SUB) to merge it to allocate another update block. If the threshold is exceeded, a random update block (RUB) will be merged instead. This threshold must be set so that SUBs with a lot of free space are not merged. Merging SUBs early will generate additional wear.

This threshold is set as a percentage (relative to number of sectors per block).

FS_NAND_CFG_TH_SUB_MIN_IDLE_TO_FOLD

This `#define` indicates the minimum idle time (specified as the number of driver accesses since the last access that has written to the SUB) for a sequential update block (SUB) to be converted to a random update block (RUB). This threshold must be set so that “hot” SUBs are not converted to RUBs.

DEVICE CONFIGURATION

You must configure the NAND translation layer for each device you use in your project. This configuration is made through a structure of type `FS_NAND_CFG`. A pointer to this structure is then passed to the function `FSDev_Open()`. Each NAND device will need to be initialized by calling `FSDev_Open()` and passing it a unique structure pointer of the type `FS_NAND_CFG`.

Note that the `FS_NAND_DfltCfg` constant should be used to initialize the `FS_NAND_CFG` structure to default values. This will ensure all fields will automatically be set to sane default values.

```
typedef struct fs_nand_cfg {
    void                *BSPPtr;                (1)
    FS_NAND_CTRLR_API  *CtrlrPtr;              (2)
    void                *CtrlrCfgPtr;          (3)
    FS_NAND_PART_API   *PartPtr;               (4)
    void                *PartCfgPtr;           (5)
    FS_SEC_SIZE        SecSize;                (6)
    FS_NAND_BLK_QTY    BlkCnt;                 (7)
    FS_NAND_BLK_QTY    BlkIxFirst;            (8)
    FS_NAND_UB_QTY     UB_CntMax;              (9)
    CPU_INT08U         RUB_MaxAssoc;          (10)
    CPU_INT08U         AvailBlkTblEntryCntMax; (11)
} FS_NAND_CFG;
```

Listing 13-3 NAND translation layer configuration structure

- L13-3(1) This field must be set to a pointer to the controller-specific BSP layer implementation's API you want the controller layer to use (see section 13-5 "Board Support Package - Generic Controller" on page 185). If you use a different controller layer implementation, that field might not be needed.
- L13-3(2) This field must be set to a pointer to the controller layer implementation's API you wish to use (see section 13-4 "Controller Layer" on page 178).
- L13-3(3) This field must be set to a pointer to the configuration structure for the specified controller layer implementation.
- L13-3(4) This field must be set to a pointer to the part layer implementation's API you wish to use (see section Listing 13-10 "API structure type for generic controller extension" on page 191)
- L13-3(5) This field must be set to a pointer to the configuration structure specific to the chosen part layer implementation.
- L13-3(6) This field must contain the sector size for the device (care must be taken when choosing sector size: see section 13-7 "Performance Considerations" on page 187). The value `FS_NAND_CFG_DEFAULT` instructs the translation layer to use the page size reported by the part layer as its sector size.

-
- L13-3(7) This field must contain the number of blocks you want μ C/FS to use. This can be useful if you want to reserve blocks for data to be used outside the file system (by a bootloader, for example). The value `FS_NAND_CFG_DEFAULT` instructs the translation layer to use the number of blocks reported by the part layer.
- L13-3(8) This field must contain the index of the first block you want μ C/FS to use. This can be useful if you want to reserve blocks for data to be used outside the file system (by a bootloader, for example).
- L13-3(9) This field must be set to the maximum number of update blocks you want the NAND translation layer to use. A greater number can improve performance but will also reduce available space on the device and consume RAM. You are encouraged to experiment with different values to evaluate which one suits your application best.
- L13-3(10) This field must be set to the maximum associativity of the random update blocks (RUB). The update blocks temporarily contain sectors from data blocks until they are merged (copied to respective data blocks). The associativity specifies the number of data blocks from which a single RUB can contain sectors. A high setting will usually lead to better overall write and read speeds and will reduce wear. However, a low setting will lower the time of execution of the worst-case write operation.
- L13-3(11) This field must be set to the size of the available blocks table. Available blocks are ready to be erased and used as update or data blocks. The table must, at least, be large enough to contain the reserved available blocks (see section “FS_NAND_CFG_RSVD_AVAIL_BLK_CNT” on page 173) and a few more for general operations. The value `FS_NAND_CFG_DEFAULT` instructs the translation layer to use 10 or $(1 + \text{FS_NAND_CFG_RSVD_AVAIL_BLK_CNT})$ entries, whichever is larger.

13-3-2 TRANSLATION LAYER SOURCE FILES

The files relevant to the NAND translation layer are outlined in this section; the generic file-system files, outlined in Chapter 3, “ μ C/FS Directories and Files” on page 29, are also required.

\Micrium\Software\uC-FS\Dev\NAND

This directory contains the NAND driver files.

\fs_dev_nand.*

These files compose the NAND translation layer. These following source files contain the code for the NAND translation layer.

\Cfg\Template\fs_dev_nand_cfg.h

This is a template file that is required to be copied to the application directory to configure the μ C/FS NAND driver based on application requirements.

13-4 CONTROLLER LAYER

The controller-layer implementations distributed with the NAND driver (see Table 13-1) support a wide variety of flash devices from major vendors.

Driver API	Files	Description
FS_NAND_CtrlrGen	<i>fs_dev_nand_ctrlr_gen.*</i> <i>in</i> <i>/Micrium/Software/uC-FS/Dev/NA</i> <i>ND/Ctrlr</i>	Supports most parallel flash devices interfaced on an MCU's external memory bus.

Table 13-1 **Controller-layer implementations provided**

Of course, it is possible that your specific device and/or micro-controller requires a different controller layer implementation, or that a different implementation could take advantage of hardware modules (like a memory controller on a MCU). Please refer to the section 13-8-4 “Controller Layer Development Guide” on page 194 for the details on how to implement your own controller layer.

13-4-1 GENERIC CONTROLLER LAYER IMPLEMENTATION

The generic controller layer driver is an implementation of the controller layer that is compatible with most parallel NAND devices and most simple memory controllers. It has the following features:

- Supports multiple sector per page
- Packs out-of-sector (OOS) metadata around reserved spare area zones
- Extensible through extensions that provides multiple hooks to allow for different ECC protection schemes (an extension for software ECC is provided)
- Supports reading ONFI parameter pages through a its `IO_Ctrl()` function
- Supports both 8-bit and 16-bit bus devices

The generic controller driver imposes a specific page layout: the sectors are stored sequentially in the main page area and OOS metadata zones are stored sequentially in the spare area, packed in the free spare zones specified by the `.FreeSpareMap` field of the associated `FS_PART_DATA` data structure. An example layout is shown below for a device with 2048 octets pages, using 512 bytes sectors.

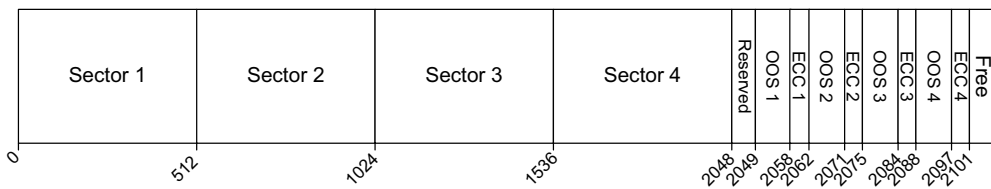

Figure 13-2 Example generic controller driver page layout

To determine if the generic controller driver is compatible with your hardware, you can study its BSP interface, described in section 13-8-1 “BSP Development Guide - Generic Controller” on page 189.

GENERIC CONTROLLER EXTENSION LAYER

The generic controller extension layer extends the functionality of the generic controller, mostly with regards to ECC. It allows for the reuse of the generic controller code, enabling easy customizations of the controller layer. The NAND driver ships with two generic controller extensions:

Extension API	Files	Description
FS_NAND_CtrlrGen_SoftECC	<i>fs_dev_nand_ctrlr_gen_soft_ecc.*</i> in <i>/Micrium/Software/uC-FS/Dev/NAND/Ctrlr</i>	Supports software ECC calculation and correction through μ C/CRC ECC modules.
FS_NAND_CtrlrGen_MicronECC	<i>fs_dev_nand_ctrlr_gen_micron_ecc.*</i> in <i>/Micrium/Software/uC-FS/Dev/NAND/Ctrlr</i>	Supports on-chip ECC hardware for some Micron parts (ex: MT29F01G08ABADA).

Table 13-2 Generic controller layer extensions provided

The software ECC generic controller extension (`FS_NAND_CtrlrGen_SoftECC`) uses μ C/CRC's ECC modules for the ECC codewords calculation and data correction. The extension is configurable through a `FS_NAND_CTRLR_GEN_SOFT_ECC_CFG` type structure. It should be initialized to the value `FS_NAND_CtrlrGen_SoftEcc_DfltCfg` before its fields are overridden to the appropriate values for your application.

```
typedef struct fs_nand_cfg {
    const ECC_CALC *ECC_ModulePtr;           (1)
} FS_NAND_CFG;
```

Listing 13-4 NAND translation layer configuration structure

L13-4(1) Pointer to an `ECC_CALC` API structure that will be used to provide software ECC calculation and correction. Refer to section 13-8-3 “ECC Module Development Guide” on page 193 and μ C/CRC's user manual for more information on ECC modules.

The Micron ECC generic controller extension (`FS_NAND_CtrlrGen_MicronECC`) allows the use of internal on-chip hardware ECC engines for some Micron NAND flash parts. The extension has been designed as an example for the Micron MT29F1G08ABADA, but should function properly with other similar Micron devices with internal ECC hardware modules. This module doesn't have any configuration options, you should use `DEF_NULL` as the generic controller extension configuration pointer (`.CtrlrExtCfg` field of the `FS_NAND_CTRLR_GEN_CFG` structure).

13-4-2 PART LAYER

There are two different part-layer implementations distributed with the NAND driver (see Table 13-3).

Driver API	Files	Description
<code>FS_NAND_PartStatic</code>	<code>fs_dev_nand_part_static.*</code> <i>in</i> <code>/Micrium/Software/uC-FS/Dev/NAND/Part</code>	Manually configure the parameters of each NAND flash device you use.
<code>FS_NAND_PartONFI</code>	<code>fs_dev_nand_part_onfi.*</code> <i>in</i> <code>/Micrium/Software/uC-FS/Dev/NAND/Part</code>	Use the parameters automatically obtained by reading the parameter page of ONFI-compliant NAND flash devices.

Table 13-3 **Part-layer implementations provided**

It is mandatory to use one part-layer implementation for the NAND driver to work. It is recommended to use one of the provided implementations.

STATICALLY CONFIGURED PART LAYER

This part-layer implementation is the basic one. It lets you set all the physical characteristics of the device through a configuration structure of type `FS_NAND_PART_STATIC_CFG`. Typically, the pointer to the configuration structure is then assigned to the field `.PartCfgPtr` of the translation layer configuration structure (see section 13-3 “NAND Translation Layer” on page 168). The pointer to the translation layer configuration structure can then be passed as an argument to the function `FSDev_Open()`. Refer to section 13-1 “Getting Started” on page 160 for an example of configuration. The part configuration

structure should be initialized to `FS_NAND_PartStatic_DfltCfg` to ensure upward compatibility with future versions. The configuration fields available for the static part layer are described in Listing 13-5:

```
typedef struct fs_nand_part_static_cfg {
    FS_NAND_BLK_QTY           BlkCnt;           (1)
    FS_NAND_PG_PER_BLK_QTY   PgPerBlk;        (2)
    FS_NAND_PG_SIZE          PgSize;           (3)
    FS_NAND_PG_SIZE          SpareSize;        (4)
    CPU_INT08U                NbrPgmPerPg;     (5)
    CPU_INT08U                BusWidth;        (6)
    CPU_INT08U                ECC_NbrCorrBits; (7)
    FS_NAND_PG_SIZE          ECC_CodewordSize; (8)
    FS_NAND_DEFECT_MARK_TYPE  DefectMarkType;  (9)
    FS_NAND_BLK_QTY           MaxBadBlkCnt;    (10)
    CPU_INT32U                MaxBlkErase;     (11)
    FS_NAND_FREE_SPARE_DATA   *FreeSpareMap;   (12)
} FS_NAND_PART_STATIC_CFG;
```

Listing 13-5 **NAND static part layer configuration structure**

- L13-5(1) Number of blocks in your device.
- L13-5(2) Number of pages per block in your device.
- L13-5(3) Page size (in octets) of your device.
- L13-5(4) Size of the spare area (in octets) of your device.
- L13-5(5) Number of partial page programming allowed before an erase operation (for example, it would be set to 4 if a device with 2048 octets pages could be written in 4 accesses of 512 octets).
- L13-5(6) Number of input/output lines of the device's bus.
- L13-5(7) Minimum required number of correctable bits per codeword for the ECC.
- L13-5(8) Codeword size required for ECC. The codeword size corresponds to the maximum data size (in octets) that must be sent to the ECC calculation module to get a single error correction code.

L13-5(9) Factory defect mark type. This determines how the translation layer can detect if a block factory is marked as a defect block. The possible values are listed below. Unless otherwise specified, any unset bit in the defect mark indicates a defective block. A byte refers to an 8-bit value, a word refers to a 16-bit value and a location is a bus width wide value (byte for 8-bit bus and word for 16-bit bus).

DEFECT_SPARE_L_1_PG_1_OR_N_ALL_0: the defect mark is in the first location of the spare area (first byte or first word, depending on bus width) of the first or last page. If the mark reads 0, the block is defective.

DEFECT_SPARE_ANY_PG_1_OR_N_ALL_0: any location in the spare area or the first or last page equal to 0 indicates a defective block.

DEFECT_SPARE_B_6_W_1_PG_1_OR_2: the defect mark is the sixth byte or the first word of the spare area (depending on bus width) of the first or second page.

DEFECT_SPARE_L_1_PG_1_OR_2: the defect mark is the first location in the spare area of the first or second page.

DEFECT_SPARE_B_1_6_W_1_IN_PG_1: the defect mark is the first and sixth byte or the first word of the spare area (depending on bus width) of the first page.

DEFECT_PG_L_1_OR_N_PG_1_OR_2: the defect mark is the first or last location of the page area in the first or second page.

L13-5(10) Maximum number of bad blocks within a single device during its lifetime.

L13-5(11) Maximum number of erase operations that can be performed on a single block.

L13-5(12) Pointer to the map of the free regions in the spare area (see Listing 13-6).

Listing 13-6 shows the data type used to specify the contiguous regions of the spare area that are available for the NAND driver to write. The map of the free regions is an array of **FS_NAND_FREE_SPARE_DATA** values. Each free contiguous section of the spare area will use one index of the array. There must also be a last entry set to **{-1, -1}** for the driver to

know when to stop parsing the table. Note that the factory defect mark should be excluded of the free regions. You can also refer to the example (see section 13-1 “Getting Started” on page 160).

```
typedef struct fs_nand_free_spare_data {
    FS_NAND_PG_SIZE  OctetOffset;           (1)
    FS_NAND_PG_SIZE  OctetLen;             (2)
} FS_NAND_FREE_SPARE_DATA;
```

Listing 13-6 NAND configuration structure for free regions of the spare area

L13-6(1) Offset (in octets) of a free region.

L13-6(2) Length (in octets) of a free region.

ONFI PART LAYER

The ONFI part layer implementation is able to obtain from ONFI compliant devices all the parameters necessary for the NAND driver to operate. The different parameters are extracted from the device parameter page. Table 13-4 lists the versions of the ONFI standard for which automatic parameter page parsing is supported. If your device does not respect this standard, it should be used with a different implementation of the part layer.

ONFI version	Supported parameter page
ONFI 3.0	YES
ONFI 2.3a	YES
ONFI 2.2	YES
ONFI 2.1	YES
ONFI 2.0	YES
ONFI 1.0	YES

Table 13-4 ONFI parameter page support for different ONFI versions

The ONFI part layer implementation does not have a lot of configuration options since most parameters are read from the device's parameter page. The part configuration structure should be initialized to `FS_NAND_PartONFI_DfltCfg` to ensure upward compatibility with future versions. The configuration fields available for the ONFI part layer implementation are described in Listing 13-7:

```
typedef struct fs_nand_part_onfi_cfg {
    FS_NAND_FREE_SPARE_DATA *FreeSpareMap;           (1)
} FS_NAND_PART_ONFI_CFG;
```

Listing 13-7 **NAND ONFI part layer configuration structure**

L13-7(1) Pointer to the map of the free regions in the spare area (see Listing 13-6).

13-5 BOARD SUPPORT PACKAGE - GENERIC CONTROLLER

If you use the generic controller layer implementation, you will have to provide a board support package to interface with your board layout and hardware. The board support package must be provided in the form of an API pointer of the type `FS_NAND_CTRLR_GEN_BSP_API`, like shown in Listing 13-8:

```
typedef struct fs_nand_ctrlr_gen_bsp_api {
    void (*Open)          (FS_ERR      *p_err);
    void (*Close)         (void);
    void (*ChipSelEn)     (void);
    void (*ChipSelDis)    (void);
    void (*CmdWr)         (CPU_INT08U  *p_cmd,
                          CPU_SIZE_T   cnt,
                          FS_ERR      *p_err);
    void (*AddrWr)        (CPU_INT08U  *p_addr,
                          CPU_SIZE_T   cnt,
                          FS_ERR      *p_err);
    void (*DataWr)        (void         *p_src,
                          CPU_SIZE_T   cnt,
                          FS_ERR      *p_err);
    void (*DataRd)        (void         *p_dest,
                          CPU_SIZE_T   cnt,
                          FS_ERR      *p_err);
    void (*WaitWhileBusy) (void         *poll_fcnt_arg,
                          CPU_BOOLEAN  (*poll_fcnt)(void *arg),
                          CPU_INT32U  to_us,
                          FS_ERR      *p_err);
} FS_NAND_CTRLR_GEN_BSP_API;
```

Listing 13-8 **BSP API type for the generic controller layer implementation**

Typically, you will provide the board support package implementation. See section 13-8-1 “BSP Development Guide - Generic Controller” on page 189 for details on how to implement the BSP layer.

13-6 BOARD SUPPORT PACKAGE - OTHER CONTROLLERS

If you use a different controller layer implementation than the generic, you will typically need a BSP layer implementation identical or mostly similar. Please refer to section 13-5 “Board Support Package - Generic Controller” on page 185 unless there is a section of this chapter dedicated to your BSP.

13-7 PERFORMANCE CONSIDERATIONS

Several performance aspects can be considered when using the NAND driver. Depending on your priorities, you will need to configure and use the NAND driver in a proper way so that your specific goals are met. The different performance metrics include the write and read/speed, the RAM usage, the data safety level and the worst-case locking time.

CHOOSING AN APPROPRIATE SECTOR SIZE

It is important to choose carefully the sector size for each device. Unless your device supports partial page programming, it is mandatory for the sector size to be identical to the page size or larger.

If your device supports partial page programming, it is possible for you to set a sector size smaller than the page size as long as it does not force the driver to exceed the maximum number of partial page programs. If this is not respected, the driver will fail the initialization phase and return an error code.

One of the advantages of choosing a sector size smaller than the page size is to reduce the RAM usage. The size of the buffers in the file system are based on the sector size. A large sector size implies large buffers.

For the best performance, the sector size should be in the ballpark of a typical transaction. If most of your write operations are a couple of octets, you should, if possible, choose a small sector size (typically 512 octets). On the other hand, if you want to obtain good transfer rates and you have large application buffers (with multimedia applications, for example), then the sector size should be set higher. The optimal choice will almost always be the same as the page size (512, 2048, 4096 octets).

CHOOSING ERROR CORRECTION CODES

Each device needs an error correction codes (ECC) module able to correct a minimal number of bits per codeword. Choosing a module that satisfies the minimum required level of error correction is often the best option if you want to avoid the extra calculation time of modules with enhanced bit error correction.

To reduce the calculation load on your CPU, it is recommended to consider using a hardware ECC module. This is especially true with parts that require more than 1 bit per codeword of error correction. These hardware ECC engines are often found in MCU and in NAND flash devices. Consult their datasheets to determine if you have access to such a feature.

If data safety is a concern, you can consider using an ECC module with better correction capacity. For most applications, the recommended level of correction is sufficient. However, using an ECC engine that can correct more bit-errors can improve long-term readability of the data, especially for cold data (that never or rarely changes). Another option is to reduce the codeword size. The same number of bit errors can be corrected, but since codewords are smaller, the bit error rate will be smaller. While those design choices will slightly improve reliability, they will also increase the overhead and hence reduce the read/write speed and increase the worst-case locking time.

CONFIGURE THE TRANSLATION LAYER

The configuration of the translation layer is complicated. Take the time needed to read carefully each description, and make sure you choose a configuration that is appropriate for your application. When, in most cases, the basic configuration will be enough, optimizing it will help you to reach your goals, whether they are about CPU usage, footprints, reliability or speed.

The translation layer configuration options are described in section 13-3-1 “Translation Layer Configuration” on page 171.

CONSIDERING ANOTHER CONTROLLER LAYER

Some MCUs have advanced peripherals that interface with NAND flash devices. If this is the case, consider using or developing a specialized controller layer implementation to take advantage of those peripherals and save some CPU time or increase performances.

13-8 DEVELOPMENT GUIDE

This section describes the code you might need to implement to adapt the driver to your specific hardware and application. Typically, you will only need to implement the BSP layer for an available controller layer implementation. In other cases, you might need to provide an implementation for the ECC module and/or the controller layer.

13-8-1 BSP DEVELOPMENT GUIDE - GENERIC CONTROLLER

If you use the generic controller layer implementation, a BSP is required so that it will work for a particular board, micro-controller or application. Other controller layer implementations might require a similar BSP layer.

The BSP must declare an instance of the BSP API type (`FS_NAND_CTRLR_GEN_BSP_API`) as a global variable within the source code. The API structure is an ordered list of function pointers used by the generic controller layer implementation. The BSP API type is shown in Listing 13-8.

An example of a BSP API structure definition is shown in Listing 13-9:

```
const FS_NAND_CTRLR_GEN_BSP_API FS_NAND_BSP_SAM9M10 = {
    FS_NAND_BSP_Open,                (1)
    FS_NAND_BSP_Close,              (2)
    FS_NAND_BSP_ChipSelEn,          (3)
    FS_NAND_BSP_ChipSelDis,         (4)
    FS_NAND_BSP_CmdWr,              (5)
    FS_NAND_BSP_AddrWr,             (6)
    FS_NAND_BSP_DataWr,             (7)
    FS_NAND_BSP_DataRd,             (8)
    FS_NAND_BSP_WaitWhileBusy       (9)
};
```

Listing 13-9 Example BSP API structure for generic controller

A proper BSP should implement all of these functions.

OPEN/CLOSE FUNCTIONS

The `Open()` and `Close()` functions will be called respectively by `FSDev_Open()` and `FSDev_Close()`. Typically, `FSDev_Open()` is called during initialization and `FSDev_Close()` is never called — closing a fixed device doesn't make much sense. When implementing the `Open()` function of the BSP layer, you should add all necessary code for the hardware initialization. That might include setting up the memory controller general settings and timings for the bank associated with the NAND device, configuring the chip select and `ready/busy` through either the memory controller or GPIO, configuring the memory controller clock, configuring the memory controller I/O pins, etc. The `Close()` function is typically left empty.

CHIP SELECTION FUNCTIONS

The `ChipSelEn()` and `ChipSelDis()` are called (in pairs) each time the device must be accessed. In these functions, you should implement any chip selection mechanism needed.

If the bus and/or hardware is shared with more than one task, the chip selection functions should also implement proper locking. If the shared bus and/or hardware must be configured differently when used outside the NAND driver, the configuration changes must be done within the `ChipSelEn()` and `ChipSelDis()` functions.

COMMAND WRITE FUNCTION

The `CmdWr()` function must write `cnt` octets on the bus with the CLE (Command Latch Enable) pin asserted.

ADDRESS WRITE FUNCTION

The `AddrWr()` function must write `cnt` octets on the bus with the ALE (Address Latch Enable) pin asserted.

DATA WRITE FUNCTION

The `DataWr()` function must write `cnt` octets on the bus with both ALE and CLE not asserted.

DATA READ FUNCTION

The `DataRd()` function must read `cnt` octets from the bus and store it, starting from the `p_src` address. The ALE and CLE signals must not be asserted.

WAIT WHILE BUSY FUNCTION

This function should block until the ready pin of the NAND device is in the appropriate state. If for any reason this pin is not accessible, you should call the `poll_fcnt()` with the `poll_fcnt_arg` as argument. This poll function will verify if the NAND device is ready by polling the NAND device status instead. Once the poll function returns `DEF_YES`, the `WaitWhileBusy()` can return without setting an error code. If the time out limit is reached, the function should return with an error code set to `FS_ERR_DEV_TIMEOUT`.

13-8-2 GENERIC CONTROLLER EXTENSION DEVELOPMENT GUIDE

The generic controller extension layer allows extending the generic controller through a number of hook functions that are used by the generic controller, when flexibility in handling a specific operation is desirable. A generic controller extension is defined through a structure of type `FS_NAND_CTRLR_GEN_EXT`, described in Listing 13-10. Note that all unused function pointers should be set to `DEF_NULL`.

```
typedef struct fs_nand_ctrlr_gen_ext {
    void          (*Init)          (FS_ERR          *p_err);          (1)

    void          *(*Open)         (FS_NAND_CTRLR_GEN_DATA *p_ctrlr_data, (2)
                                   void          *p_ext_cfg,
                                   FS_ERR          *p_err);

    void          (*Close)        (void          *p_ext_data);      (3)

    FS_NAND_PG_SIZE (*Setup)      (FS_NAND_CTRLR_GEN_DATA *p_ctrlr_data, (4)
                                   void          *p_ext_data,
                                   FS_ERR          *p_err);

    void          (*RdStatusChk) (void          *p_ext_data,      (5)
                                   FS_ERR          *p_err);

    void          (*ECC_Calc)     (void          *p_ext_data,      (6)
                                   void          *p_sec_buf,
                                   void          *p_oos_buf,
                                   FS_NAND_PG_SIZE oos_size,
                                   FS_ERR          *p_err);

    void          (*ECC_Verify)  (void          *p_ext_data,      (7)
                                   void          *p_sec_buf,
                                   void          *p_oos_buf,
                                   FS_NAND_PG_SIZE oos_size,
                                   FS_ERR          *p_err);
} FS_NAND_CTRLR_GEN_EXT;
```

Listing 13-10 API structure type for generic controller extension

- L13-10(1) The **Init()** function provides an opportunity to initialize an extension. This will be called only once, when the extension is registered with the generic controller (during **FSDev_Open()**). If multiple generic controller instances are configured with the same extension, the **Init()** function will still be called only once.
- L13-10(2) The **Open()** function is called by the generic controller's own **Open()** function. This function will also receive the controller extension configuration pointer.
- L13-10(3) The **Close()** function might be called by the generic controller's own **Close()** function and allow the extension to release its resources. **Close()** will typically never be called.
- L13-10(4) The **Setup()** function is called during the generic controller's own **Setup()** function and provides an opportunity to setup some internal parameters according to the generic controller's operating conditions. The generic controller's instance data is provided as an argument to this function. The function must return the amount of required OOS storage space, in octets (ECC data, for example).
- L13-10(5) The **RdStatusChk()** function is called after a sector read operation, by the generic controller's **SecRd()** function. It should determine if a read error has occurred and return an error accordingly.
- L13-10(6) The **ECC_Calc()** function is called before a sector is written to the NAND device by the generic controller's **SecWr()** function, and provides an opportunity to calculate the ECC data and to append it to the OOS metadata.
- L13-10(7) The **ECC_Verify()** function is called after a sector is read from the NAND device by the generic controller's **SecRd()** function. It should read the ECC data from the OOS metadata, verify the sector and OOS data integrity, and correct any errors found if possible. It should return an appropriate error code if ECC errors are found.

13-8-3 ECC MODULE DEVELOPMENT GUIDE

Before undertaking the task of writing a software ECC module, or a software interface to a hardware ECC module, you should evaluate whether or not modifications to the controller layer are needed as well. Some hardware ECC modules integrated within a NAND device or a micro-controller's memory controller can be handled through a generic controller extension module.

However, if your ECC module can be interfaced with the software ECC generic controller extension, you could limit the code to be developed to the ECC layer only. If this is the case, you will need to provide the implementation of the API as shown in Listing 13-11:

```
typedef struct ecc_calc {
    CPU_SIZE_T      BufLenMin;           (1)
    CPU_SIZE_T      BufLenMax;          (2)
    CPU_INT08U      ECC_Len;            (3)
    CPU_INT08U      NbrCorrectableBits; (4)
    ECC_CALC_FNCT   Calc;               (5)
    ECC_CHK_FNCT    Chk;                (6)
    ECC_CORRECT_FNCT Correct;           (7)
} ECC_CALC;
```

Listing 13-11 ECC API type definition

- L13-11(1) Minimum buffer length that the ECC module can handle.
- L13-11(2) Maximum buffer length that the ECC module can handle.
- L13-11(3) Length, in octets, of the code for a single buffer.
- L13-11(4) Number of bits the module can correct for each buffer.
- L13-11(5) Pointer to the code calculation function.
- L13-11(6) Pointer to the error detection function.
- L13-11(7) Pointer to the error correction function.

For more details on the implementation, please refer to the μ C/CRC User Manual.

13-8-4 CONTROLLER LAYER DEVELOPMENT GUIDE

To fully take advantage of advanced peripherals (for example, NAND flash controllers), you might decide to provide your own implementation of the controller layer. The controller layer is one level above the BSP layer. Its interface is more flexible, but is also more complex to implement. If you choose that route, it is strongly recommended to use the provided implementations as an example. Listing 13-12 describes the API that must be implemented for the controller layer.

```

typedef struct fs_nand_ctrlr_api {
    void          *(*Open)          (FS_NAND_PART_API *p_part_api,
                                     void             *p_bsp_api,
                                     void             *p_ctrlr_cfg,
                                     FS_ERR           *p_err);

    void          (*Close)         (void             *p_ctrlr_data);

    FS_NAND_PART_DATA *(*PartDataGet) (void             *p_ctrlr_data);

    FS_NAND_PG_SIZE (*Setup)       (void             *p_ctrlr_data,
                                     FS_NAND_PG_SIZE sec_size,
                                     FS_ERR           *p_err);

    void          (*SecRd)         (void             *p_ctrlr_data,
                                     void             *p_dest,
                                     void             *p_dest_oos,
                                     FS_SEC_NBR      sec_ix_phy,
                                     FS_ERR           *p_err);

    void          (*OOSRdRaw)     (void             *p_ctrlr_data,
                                     void             *p_dest_oos,
                                     FS_SEC_NBR      sec_nbr_phy,
                                     FS_NAND_PG_SIZE offset,
                                     FS_NAND_PG_SIZE length,
                                     FS_ERR           *p_err);

    void          (*SpareRdRaw)   (void             *p_ctrlr_data,
                                     void             *p_dest_oos,
                                     FS_SEC_QTY      pg_nbr_phy,
                                     FS_NAND_PG_SIZE offset,
                                     FS_NAND_PG_SIZE length,
                                     FS_ERR           *p_err);

    void          (*SecWr)        (void             *p_ctrlr_data,
                                     void             *p_src,
                                     void             *p_src_spare,
                                     FS_SEC_NBR      sec_nbr_phy,
                                     FS_ERR           *p_err);

    void          (*BlkErase)     (void             *p_ctrlr_data,
                                     CPU_INT32U      blk_nbr_phy,
                                     FS_ERR           *p_err);

    void          (*IO_Ctrl)      (void             *p_ctrlr_data,
                                     CPU_INT08U      cmd,
                                     void             *p_buf,
                                     FS_ERR           *p_err);
} FS_NAND_CTRLR_API;

```

Listing 13-12 Controller API type definition

Before implementing the following functions, it is important to understand the difference between out-of-sector (OOS) data and the spare area. In a NAND device, each page has a spare area, typically used to store metadata and error correction codes (ECC). The spare area also contains a factory defect mark and, optionally, reserved sections. In the implementation of the μ C/FS NAND driver, the OOS data is metadata sent to the controller layer by the translation layer. It must be stored in the spare area, without overwriting the bad block mark and without writing to the reserved section. It must also be protected by ECC. The OOS data is only a part of what is inside the spare area. It doesn't include the factory defect marks, the reserved sections and the ECC data. Also, if the sector size is not equal to the page size, the OOS data will be associated to a single sector, while the spare area will be associated to a single page. In that case, multiple OOS sections would be fit in a single spare area.

OPEN/CLOSE FUNCTIONS

The `Open()` and `Close()` function will be called respectively by `FSDev_Open()` and `FSDev_Close()`. Typically, `FSDev_Open()` is called during initialization and `FSDev_Close()` is never called. When implementing the `Open()` function of the controller layer, you should typically add all necessary code for the bus/controller initialization (or call the `Open()` function of the BSP layer). You should also allocate the necessary memory and perform all the operations that need to be done a single time only, when opening the device. The `Close()` function is typically left empty.

PART DATA GET FUNCTION

The `PartDataGet()` function should return an instance of the type `FS_NAND_PART_DATA` associated to a particular device.

SETUP FUNCTION

The `Setup()` function is called a single time, after the `Open()` function. It must perform the proper calculation to make sure that the out-of-sector data (OOS) and the error correction codes (ECC) can fit in the spare area.

SECTOR READ FUNCTION

The `SectorRd()` function must copy the data found at the physical sector `sec_ix_phy` into the `p_dest` buffer. It must also copy the out-of-sector data (OOS - the section of the spare area, excluding ECC, bad block marks and unused sections) into the `p_dest_oos` buffer. Before returning successfully, the function should check for errors and correct them, if needed (with ECC).

OUT-OF-SECTOR (OOS) RAW READ FUNCTION

The `OOSRdRaw()` function must copy `len` octets from the `offset` octet in the OOS of the sector `sec_ix_phy` into the `p_dest_oos` buffer. This function should not perform error correction.

SPARE AREA RAW READ FUNCTION

The `SpareRdRaw()` function must copy `len` octets from the `offset` octet in the spare area of the page `pg_ix_phy` into the `p_dest_spare` buffer. This function should not perform error correction.

SECTOR WRITE FUNCTION

The `SectorWr()` function must write the data found in the `p_src` buffer into the physical sector `sec_ix_phy` of the NAND device. It must also write the out-of-sector data (OOS - the section of the spare area, excluding ECC, bad block marks and unused sections) found in the `p_src_oos` buffer into the spare area. It should also store error correction codes (ECC) in the spare area.

BLOCK ERASE FUNCTION

The `BlkErase()` function should erase the block `blk_ix_phy` of the device.

IO CONTROL FUNCTION

The `IO_Ctrl()` function body can be left empty. It was created to perform device or controller specific commands without the need of a custom API. It can simply return the `FS_ERR_DEV_INVALID_IO_CTRL` error code.

Note that the ONFI part layer implementation makes use of the `FS_DEV_IO_CTRL_NAND_PARAM_PG_RD` I/O control operation. In order to retain compatibility with the ONFI part layer implementation, your controller implementation must support that operation.

NOR Flash Driver

NOR flash is a low-capacity on-board storage solution. Traditional parallel NOR flash, located on the external bus of a CPU, offers extremely fast read performance, but comparatively slow writes (typically performed on a word-by-word basis). Often, these store application code in addition to providing a file system. The parallel architecture of traditional NOR flash restricts use to a narrow class of CPUs and may consume valuable PCB space. Increasingly, serial NOR flash are a valid alternative, with fast reads speeds and comparable capacities, but demanding less of the CPU and hardware, being accessed by SPI or SPI-like protocols. Table 14-1 briefly compares these two technologies; specific listings of supported devices are located in section 14-5 “Physical-Layer Drivers” on page 214.

Device Category	Typical Packages	Manufacturers	Description
Parallel NOR Flash	TSOP32, TSOP48, BGA48, TSOP56, BGA56	AMD (Spansion) Intel (Numonyx) SST ST (Numonyx)	Parallel data (8- or 16-bit) and address bus (20+ bits). Most devices have CFI ‘query’ information and use one of several standard command sets.
Serial NOR Flash	SOIC-8N, SOIC-8W, SOIC-16, WSON, USON	Atmel SST ST (Numonyx)	SPI or multi-bit SPI-like interface. Command sets are generally similar.

Table 14-1 **NOR flash devices**

14-1 FILES AND DIRECTORIES

The files inside the RAM disk driver directory are outlined in this section; the generic file-system files, outlined in Chapter 3, “ μ C/FS Directories and Files” on page 29, are also required.

\Micrium\Software\uC-FS\Dev

This directory contains device-specific files.

\Micrium\Software\uC-FS\Dev\NOR

This directory contains the NOR driver files.

fs_dev_nor.*

These files are device driver for NOR flash devices. This file requires a set of BSP functions be defined in a file named `fs_dev_nor_bsp.c` to work with a certain hardware setup.

.\BSP\Template\fs_dev_nor_bsp.c

This is a template BSP for traditional parallel NOR devices. See section C-10 “NOR Flash BSP” on page 473 for more information.

.\BSP\Template (SPI)\fs_dev_nor_bsp.c

This is a template BSP for serial (SPI) NOR devices. See section C-11 “NOR Flash SPI BSP” on page 480 for more information.

.\BSP\Template (SPI GPIO)\fs_dev_nor_bsp.c

This is a template BSP for serial (SPI) NOR devices using GPIO (bit-banging). See section C-11 “NOR Flash SPI BSP” on page 480 for more information.

.\PHY

This directory contains physical-level drivers for specific NOR types:

<code>fs_dev_nor_amd_1x08.*</code>	CFI-compatible parallel NOR implementing AMD command set (1 chip, 8-bit data bus)
<code>fs_dev_nor_amd_1x16.*</code>	CFI-compatible parallel NOR implementing AMD command set (1 chip, 16-bit data bus)
<code>fs_dev_nor_intel.*</code>	CFI-compatible parallel NOR implementing Intel command set (1 chip, 16-bit data bus)
<code>fs_dev_nor_sst39.*</code>	SST SST39 Multi-Purpose Flash
<code>fs_dev_nor_stm25.*</code>	ST STM25 serial flash
<code>fs_dev_nor_sst25.*</code>	SST SST25 serial flash

\Micrium\Software\uC-FS\Examples\BSP\Dev\NOR

Each subdirectory contains an example BSP for a particular platform. These are named according to the following rubric:

<Chip Manufacturer>\<Board or CPU>\fs_dev_nor_bsp.c

14-2 DRIVER AND DEVICE CHARACTERISTICS

NOR devices, no matter what attachment interface (serial or parallel), share certain characteristics. The medium is always organized into units (called blocks) which are erased at the same time; when erased, all bits are 1. Only an erase operation can change a bit from a 0 to a 1, but any bit can be individually programmed from a 1 to a 0. The $\mu\text{C}/\text{FS}$ driver requires that any 2-byte word can be individually accessed (read or programmed).

The driver RAM requirement depends on flash parameters such as block size and run-time configurations such as sector size. For a particular instance, a general formula can give an approximate:

```
if (secs_per_blk < 255) {
    temp1 = ceil(blk_cnt_used / 8) + (blk_cnt_used * 1);
} else {
    temp1 = ceil(blk_cnt_used / 8) + (blk_cnt_used * 2);
}
if (sec_cnt < 65535) {
    temp2 = sec_cnt * 2;
} else {
    temp2 = sec_cnt * 4;
}
temp3 = sec_size;
TOTAL = temp1 + temp2 + temp3;
```

where

<code>secs_per_blk</code>	The number of sectors per block.
<code>blk_cnt_used</code>	The number of blocks on the flash which will be used for the file system.
<code>sec_cnt</code>	The total number of sectors on the device.
<code>sec_size</code>	The sector size configured for the device, in octets.

`secs_per_blk` and `sec_cnt` can be calculated from more basic parameters:

```
secs_per_blk = floor(blk_size / sec_size);
sec_cnt      = secs_per_blk * blk_cnt_used;
```

where

blk_size The size of a block on the device, in octets

Take as an example a 16-Mb NOR that is entirely dedicated to file system usage, with a 64-KB block size, configured with a 512-B sector. The following parameters describe the format:

```
blk_cnt_used = 32;
blk_size     = 65536;
sec_size     = 512;
secs_per_blk = 65536 / 512 = 128;
sec_cnt      = 128 * 32    = 4096;
```

and the RAM usage is approximately

```
temp1 = (32 / 8) + (32 * 2) = 68;
temp2 = 4096 * 2 = 8192;
temp3 = 512;
TOTAL = 68 + 8192 + 512 = 8772;
```

In this example, as in most situations, increasing the sector size will decrease the RAM usage. If the sector size were 1024-B, only 5188-B would have been needed, but a moderate performance penalty would be paid.

14-3 USING A PARALLEL NOR DEVICE

To use the NOR driver, five files, in addition to the generic file system files, must be included in the build:

- `fs_dev_nor.c`.
- `fs_dev_nor.h`.
- `fs_dev_nor_bsp.c` (located in the user application or BSP).
- A physical-layer driver (e.g., as provided in `\Micrium\Software\uC-FS\Dev\NOR\PHY`)

The file `fs_dev_nor.h` must also be `#included` in any application or header files that directly reference the driver (for example, by registering the device driver). The following directories must be on the project include path:

- `\Micrium\Software\uC-FS\Dev\NOR`
- `\Micrium\Software\uC-FS\Dev\NOR\PHY`

A single NOR volume is opened as shown in Table 14-1. The file system initialization (`FS_Init()`) function must have previously been called.

ROM characteristics and performance benchmarks of the NOR driver can be found in section 9-1-1 “Driver Characterization” on page 113. The NOR driver also provides interface functions to perform low-level operations (see section A-12 “FAT System Driver Functions” on page 386).

```

CPU_BOOLEAN App_FS_AddNOR (void)
{
    FS_DEV_NOR_CFG nor_cfg;
    FS_ERR          err;
    FS_DrvAdd((FS_DEV_API *)&FSDev_Nor,          /* (1) */
              (FS_ERR *)&err);
    if ((err != FS_ERR_NONE) && (err != FS_ERR_DEV_DRV_ALREADY_ADDED)) {
        return (DEF_FAIL);
    }

    /* (2) */
    nor_cfg.AddrBase      = APP_CFG_FS_NOR_ADDR_BASE;
    nor_cfg.RegionNbr    = APP_CFG_FS_NOR_REGION_NBR;
    nor_cfg.AddrStart     = APP_CFG_FS_NOR_ADDR_START;
    nor_cfg.DevSize       = APP_CFG_FS_NOR_DEV_SIZE;
    nor_cfg.SecSize       = APP_CFG_FS_NOR_SEC_SIZE;
    nor_cfg.PctRsvd       = APP_CFG_FS_NOR_PCT_RSVD;
    nor_cfg.PctRsvdSecActive = APP_CFG_FS_NOR_PCT_RSVD_SEC_ACTIVE;
    nor_cfg.EraseCntDiffTh = APP_CFG_FS_NOR_ERASE_CNT_DIFF_TH;
    nor_cfg.PhyPtr        = (FS_DEV_NOR_PHY_API *)APP_CFG_FS_NOR_PHY_PTR;
    nor_cfg.BusWidth      = APP_CFG_FS_NOR_BUS_WIDTH;
    nor_cfg.BusWidthMax   = APP_CFG_FS_NOR_BUS_WIDTH_MAX;
    nor_cfg.PhyDevCnt     = APP_CFG_FS_NOR_PHY_DEV_CNT;
    nor_cfg.MaxClkFreq    = APP_CFG_FS_NOR_MAX_CLK_FREQ;

    /* (3) */
    FSDev_Open((CPU_CHAR *)"nor:0:",             /* (a) */
              (void *)&nor_cfg,                 /* (b) */
              (FS_ERR *)&err);

    switch (err) {
        case FS_ERR_NONE:
            APP_TRACE_DBG((" ...opened device.\r\n"));
            break;
        case FS_ERR_DEV_INVALID_LOW_FMT:         /* Low fmt invalid. */
            APP_TRACE_DBG((" ...opened device (not low-level formatted).\r\n"));
            FSDev_NOR_LowFmt("nor:0:", &err);    /* (4) */
            if (err != FS_ERR_NONE) {
                APP_TRACE_DBG((" ...low-level format failed.\r\n"));
                return (DEF_FAIL);
            }
            break;
        default:                                 /* Device error. */
            APP_TRACE_DBG((" ...opening device failed w/err = %d.\r\n\r\n", err));
            return (DEF_FAIL);
    }
}

```

```

FSVol_Open((CPU_CHAR      *)"nor:0:",      /* (5) */
           (CPU_CHAR      *)"nor:0:",      /* (a) */
           (FS_PARTITION_NBR ) 0,          /* (b) */
           (FS_ERR          *)&err);      /* (c) */

switch (err) {
case FS_ERR_NONE:
    APP_TRACE_DBG((" ...opened volume (mounted).\r\n"));
    break;
case FS_ERR_PARTITION_NOT_FOUND:          /* Volume error. */
    APP_TRACE_DBG((" ...opened device (not formatted).\r\n"));
    FSVol_Fmt("nor:0:", (void *)0, &err); /* (6) */
    if (err != FS_ERR_NONE) {
        APP_TRACE_DBG((" ...format failed.\r\n"));
        return (DEF_FAIL);
    }
    break;
default:                                  /* Device error. */
    APP_TRACE_DBG((" ...opening volume failed w/err = %d.\r\n\r\n", err));
    return (DEF_FAIL);
}
return (DEF_OK);
}

```

Listing 14-1 Opening a NOR device volume

- L14-1(1) Register the NOR device driver `FSDev_NOR`.
- L14-1(2) The NOR device configuration should be assigned. For more information about these parameters, see section D-3 “FS_DEV_NOR_CFG” on page 485.
- L14-1(3) `FSDev_Open()` opens/initializes a file system device. The parameters are the device name (3a) and a pointer to a device driver-specific configuration structure (3b). The device name (3a) is composed of a device driver name (“nor”), a single colon, an ASCII-formatted integer (the unit number) and another colon.
- L14-1(4) `FSDev_NOR_LowFmt()` low-level formats a NOR. If the NOR has never been used with μ C/FS, it must be low-level formatted before being used. Low-level formatting will associate logical sectors with physical areas of the device.

`FSVol_Open()` opens/mounts a volume. The parameters are the volume name (5a), the device name (5b) and the partition that will be opened (5c). There is no restriction on the volume name (5a); however, it is typical to give the volume the same name as the underlying device. If the default partition is to be opened, or if the device is not partition, then the partition number (5c) should be zero.

`FSVol_Fmt()` formats a file system device. If the NOR has just been low-level format, it will have no file system on it after it is opened (it will be unformatted) and must be formatted before files can be created or accessed.

If the NOR initialization succeeds, the file system will produce the trace output as shown in Figure 14-1 (if a sufficiently high trace level is configured). See section E-9 “Trace Configuration” on page 507 about configuring the trace level.



```

=====
FS INITIALIZATION
=====
Initializing FS...
-----
Adding MSC device driver ...
-----
Adding/opening NOR volume "nor:0"...
FSDev_NOR_SST39_Open(): Dev size: 4194304
                        Algo   : 0x0701
                        Blk cnt : 64
                        Blk size: 65536
NOR FLASH FOUND: Name   : "nor:0:"
                  Sec Size : 512 bytes
                  Size    : 7200 secs
                  Rsvd    : 10% (800 secs)
                  Active blks: 3
FSDev_NOR_Mount(): Low-level format invalid: 0 invalid blks found.
                  ..opened device (not low-level formatted).
NOR FLASH MOUNT: Name   : "nor:0:"
                  Blks valid : 0
                  erased   : 64
                  erase q  : 0
                  Secs valid : 0
                  erased   : 8000
                  invalid  : 0
                  Erase cnt min: 0
                  Erase cnt max: 0
FSPartition_RdEntry(): Invalid partition sig: 0xFFFF != 0xAA55.
FS_FAT_Open(): Invalid boot sec sig: 0xFFFF != 0xAA55
               ..opened device (not formatted).
FSPartition_RdEntry(): Invalid partition sig: 0xFFFF != 0xAA55.
FS_FAT_Open(): Invalid boot sec sig: 0xFFFF != 0xAA55
FS_FAT_Fmt(): Creating file system:
                  Type      : FAT16
                  Sec size  : 512 B
                  Clus size: 1 sec
                  Vol size  : 7200 sec
                  # Clus   : 7111
                  # FATs   : 2
FS_FAT_Open(): File system found: Type      : FAT16
                  Sec size  : 512 B
                  Clus size: 1 sec
                  Vol size  : 7200 sec
                  # Clus   : 7111
                  # FATs   : 2

```

Figure 14-1 NOR detection trace output

14-3-1 DRIVER ARCHITECTURE

When used with a parallel NOR device, the NOR driver is three layered, as depicted in the figure below. The generic NOR driver, as always, provides sector abstraction and performs wear-leveling (to make certain all blocks are used equally). Below this, the physical-layer driver implements a particular command set to read and program the flash and erase blocks. Lastly, a BSP implements function to initialize and uninitialize the bus interface. Device commands are executed by direct access to the NOR, at locations appropriately offset from the configured base address.

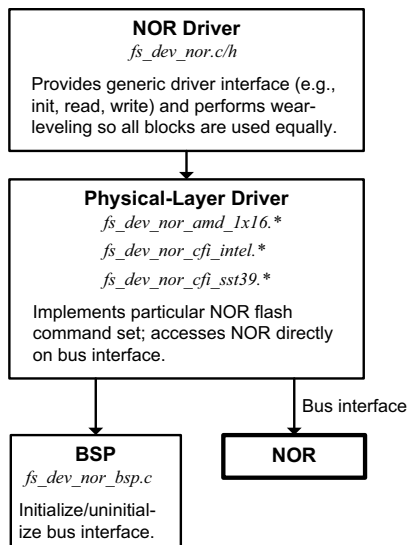

Figure 14-2 **NOR driver architecture (parallel NOR flash)**

14-3-2 HARDWARE

Parallel NOR devices typically connect to a host MCU/MPU via an external bus interface (EBI), with an 8- or 16-bit data lines and 20 or more address lines (depending on the device size). Many silicon vendors offer parallel NOR product lines; most devices currently marketed are conformant to the Common Flash Interface (CFI). A set of query information allows the μ C/FS NOR driver physical-layer drivers to interface with almost any NOR flash without configuration or modification. The standard query information provides the following details:

- Command set. Three different command sets are common: Intel, AMD and SST. All three are supported.
- Geometry. A device is composed of one or more regions of identically-sized erase blocks. Uniform devices contain only one region. Boot-block devices often have one or two regions of small blocks for code storage at the top or bottom of the device. All of these are supported by the NOR driver.

Offset	Length (Bytes)	Contents
0x10	1	Query string "Q"
0x11	1	Query string "R"
0x12	1	Query string "Y"
0x13	2	Command set
0x27	1	Device size, in bytes = 2n
0x2A	2	Maximum number of bytes in multi-byte write = 2N
0x2C	1	Number of erase block regions = m
0x2D	2	Region 1: Number of erase blocks = x + 1
0x2F	2	Region 1: Size of each erase block = y * 256 (bytes)
0x31	2	Region 2: Number of erase blocks = x + 1
0x33	2	Region 2: Size of each erase block = y * 256 (bytes)
.		
.		
.		
0x2D + (m-1) * 4	2	Region m: Number of erase blocks = x + 1
0x2F + (m-1) * 4	2	Region m: Size of each erase block = y * 256 (bytes)

Table 14-2 CFI query information

Table 14-2 gives the format of CFI query information. The first three bytes should constitute the marker string "QRY", by which the retrieval of correct parameters is verified. A two-byte command set identifier follows; this must match the identifier for the command set supported by the physical-layer driver. Beyond is the geometry information: the device size, the number of erase block regions, and the size and number of blocks in each region. For most flash, these regions are contiguous and sequential, the first at the beginning of the device, the second just after. Since this is not always true (see section 14-5-3

“FSDev_NOR_SST39” on page 216 for an example), the manufacturer’s information should always be checked and, for atypical devices, the physical-layer driver copied to the application directory and modified.

Command Set Identifier	Description
0x0001	Intel
0x0002	AMD/Spansion
0x0003	Intel
0x0102	SST

Table 14-3 Common command sets

14-3-3 NOR BSP OVERVIEW

A BSP is required so that a physical-layer driver for a parallel flash will work on a particular system. The functions shown in the table below must be implemented. Please refer to section C-10 “NOR Flash BSP” on page 473 for the details about implementing your own BSP.

Function	Description
FSDev_NOR_BSP_Open()	Open (initialize) bus for NOR.
FSDev_NOR_BSP_Close()	Close (uninitialize) bus for NOR.
FSDev_NOR_BSP_Rd_XX()	Read from bus interface.
FSDev_NOR_BSP_RdWord_XX()	Read word from bus interface.
FSDev_NOR_BSP_WrWord_XX()	Write word to bus interface
FSDev_NOR_BSP_WaitWhileBusy()	Wait while NOR is busy.

Table 14-4 NOR BSP functions

The `Open()`/`Close()` functions are called upon open/close; these calls are always matched.

The remaining functions (`Rd_XX()`, `RdWord_XX()`, `WrWord_XX()`) read data from or write data to the NOR. If a single parallel NOR device will be accessed, these function may be defined as macros to speed up bus accesses.

14-4 USING A SERIAL NOR DEVICE

When used with a serial NOR device, the NOR driver is three layered, as depicted in the figure below. The generic NOR driver, as always, provides sector abstraction and performs wear-leveling (to make certain all blocks are used equally). Below this, the physical-layer driver implements a particular command set to read and program the flash and erase blocks. Lastly, a BSP implements function to communicate with the device over SPI. Device commands are executed through this BSP.

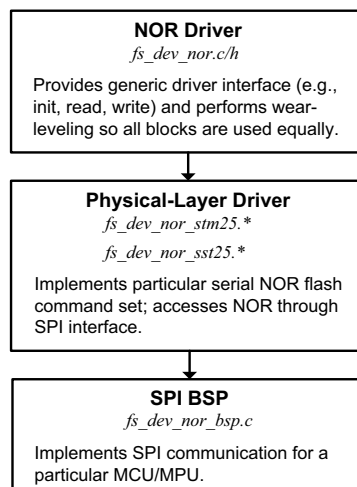

Figure 14-3 NOR driver architecture (serial NOR flash)

14-4-1 HARDWARE

Serial NOR devices typically connect to a host MCU/MPU via an SPI or SPI-like bus. Eight-pin devices, with the functions listed in Table 14-5, or similar, are common, and are often employed with the HOLD and WP pins held high (logic low, or inactive), as shown in Table 14-5. As with any SPI device, four signals are used to communicate with the host (CS, SI, SCK and SO).

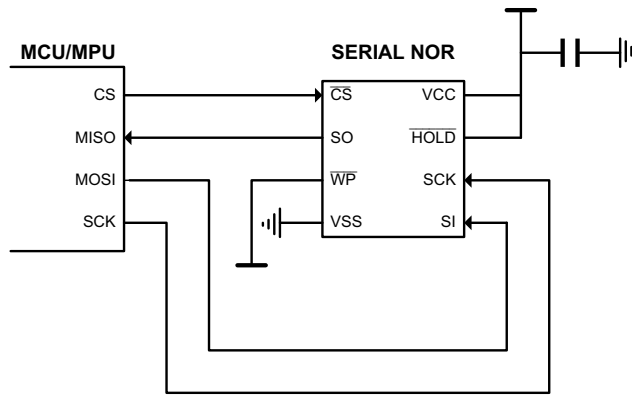

Figure 14-4 Typical serial NOR connections

14-4-2 NOR SPI BSP OVERVIEW

An NOR BSP is required so that a physical-layer driver for a serial flash will work on a particular system. For more information about these functions, see section C-11 on page 480.

Function	Description
FSDev_NOR_BSP_SPI_Open()	Open (initialize) SPI.
FSDev_NOR_BSP_SPI_Close()	Close (uninitialize) SPI.
FSDev_NOR_BSP_SPI_Lock()	Acquire SPI lock.
FSDev_NOR_BSP_SPI_Unlock()	Release SPI lock.
FSDev_NOR_BSP_SPI_Rd()	Read from SPI.
FSDev_NOR_BSP_SPI_Wr()	Write to SPI.
FSDev_NOR_BSP_SPI_ChipSelEn()	Enable chip select.
FSDev_NOR_BSP_SPI_ChipSelDis()	Disable chip select.
FSDev_NOR_BSP_SPI_SetClkFreq()	Set SPI clock frequency.

Table 14-5 **NOR SPI BSP functions**

14-5 PHYSICAL-LAYER DRIVERS

The physical-layer drivers distributed with the NOR driver (see the table below) support a wide variety of parallel and serial flash devices from major vendors. Whenever possible, advanced programming algorithms (such as the common buffered programming commands) are used to optimize performance. Within the diversity of NOR flash, some may be found which implement the basic command set, but not the advanced features; for these, a released physical-layer may need to be modified. In all cases, the manufacturer's reference should be compared to the driver description below.

Driver API	Files	Description
FSDev_NOR_AMD_1x08	fs_dev_nor_amd_1x08.*	Supports CFI-compatible devices with 8-bit data bus implementing AMD command set.
FSDev_NOR_AMD_1x16	fs_dev_nor_amd_1x16.*	Supports CFI-compatible devices with 16-bit data bus implementing AMD command set.
FSDev_NOR_Intel_1x16	fs_dev_nor_intel.*	Supports CFI-compatible devices with 16-bit data bus implementing Intel command set.
FSDev_NOR_SST39	fs_dev_nor_sst39.*	Supports various SST SST39 devices with 16-bit data bus.
FSDev_NOR_STM29_1x08	fs_dev_nor_stm29_1x08.*	Supports various ST M29 devices with 8-bit data bus.
FSDev_NOR_STM29_1x16	fs_dev_nor_stm29_1x16.*	Supports various ST M29 devices with 16-bit data bus.
FSDev_NOR_STM25	fs_dev_nor_stm25.*	Supports various ST M25 serial devices.
FSDev_NOR_SST25	fs_dev_nor_sst25.*	Supports various SST SST25 serial devices.

Table 14-6 Physical-layer drivers

14-5-1 FSDEV_NOR_AMD_1X08, FSDEV_NOR_AMD_1X16

FSDev_NOR_AMD_1x08 and FSDev_NOR_AMD_1x16 support CFI NOR flash implementing AMD command set, including:

- Most AMD and Spansion devices
- Most ST/Numonyx devices
- Others

The fast programming command “write to buffer and program”, supported by many flash implementing the AMD command set, is used in this driver if the “Maximum number of bytes in a multi-byte write” (in the CFI device geometry definition) is non-zero.

Some flash implementing AMD command set have non-zero multi-byte write size but do not support the “write to buffer & program” command. Often these devices will support alternate fast programming methods. This driver MUST be modified for those devices, to ignore the multi-byte write size in the CFI information. Define `NOR_NO_BUF_PGM` to force this mode of operation.

14-5-2 FSDEV_NOR_INTEL_1X16

FSDev_NOR_Intel_1x16 supports CFI NOR flash implementing Intel command set, including

- Most Intel/Numonyx devices
- Some ST/Numonyx M28 device
- Others

14-5-3 FSDEV_NOR_SST39

FSDev_NOR_SST39 supports SST's SST39 Multi-Purpose Flash memories, as described in various datasheets at SST (<http://www.sst.com>). SST39 devices use a modified form of the AMD command set. A more significant deviation is in the CFI device geometry information, which describes two different views of the memory organization—division in to small sectors and division into large blocks—rather than contiguous, separate regions. The driver always uses the block organization.

14-5-4 FSDEV_NOR_STM25

FSDev_NOR_STM25 supports Numonyx/ST's M25 & M45 serial flash memories, as described in various datasheets at Numonyx (<http://www.numonyx.com>). This driver has been tested with or should work with the devices in the table below.

The M25P-series devices are programmed on a page (256-byte) basis and erased on a sector (32- or 64-KB) basis. The M25PE-series devices are also programmed on a page (256-byte) basis, but are erased on a page, subsector (4-KB) or sector (64-KB) basis.

Manufacturer	Device	Capacity	Block Size	Block Count
ST	M25P10	1 Mb	64-KB	2
ST	M25P20	2 Mb	64-KB	4
ST	M25P40	4 Mb	64-KB	8
ST	M25P80	8 Mb	64-KB	16
ST	M25P16	16 Mb	64-KB	32
ST	M25P32	32 Mb	64-KB	64
ST	M25P64	64 Mb	64-KB	128
ST	M25P128	128 Mb	64-KB	256
ST	M25PE10	1 Mb	64-KB	2
ST	M25PE20	2 Mb	64-KB	4
ST	M25PE40	4 Mb	64-KB	8
ST	M25PE80	8 Mb	64-KB	16
ST	M25PE16	16 Mb	64-KB	32

Table 14-7 Supported M25 serial flash

14-5-5 FSDEV_NOR_SST25

FSDev_NOR_SST25 supports SST's SST25 serial flash memories, as described in various datasheets at Numonyx (<http://www.numonyx.com>). This driver has been tested with or should work with the devices in the table below.

The M25P-series devices are programmed on a word (2-byte) basis and erased on a sector (4-KB) or block (32-KB) basis. The revision A devices and revision B devices differ slightly. Both have an Auto-Address Increment (AAI) programming mode. In revision A devices, the programming is performed byte-by-byte; in revision B devices, word-by-word. Revision B devices can also be erased on a 64-KB block basis and support a command to read a JEDEC-compatible ID.

Manufacturer	Device	Capacity	Block Size	Block Count
SST	SST25VF010B	1 Mb	4-KB	32
SST	SST25VF020B	2 Mb	4-KB	64
SST	SST25VF040B	4 Mb	4-KB	128
SST	SST25VF080B	8 Mb	32-KB	32
SST	SST25VF016B	16 Mb	32-KB	64
SST	SST25VF032B	32 Mb	32-KB	128

Table 14-8 Supported SST25 serial flash

The MSC driver supports USB mass storage class devices (i.e., USB drives, thumb drives) using the μ C/USB host stack.

15-1 FILES AND DIRECTORIES

The files inside the MSC driver directory are outlined in this section; the generic file-system files, outlined in Chapter 3, “ μ C/FS Directories and Files” on page 29, are also required.

`\Micrium\Software\uC-FS\Dev`

This directory contains device-specific files.

`\Micrium\Software\uC-FS\Dev\MSC`

This directory contains the MSC driver files.

`fs_dev_msc.*` constitute the MSC device driver.

`\Micrium\Software\uC-USB`

This directory contains the code for μ C/USB. For more information, please see the μ C/USB user manual.

15-2 USING THE MSC DRIVER

To use the MSC driver, two files, in addition to the generic file system files, must be included in the build:

- `fs_dev_msc.c`.
- `fs_dev_msc.h`.

The file `fs_dev_msc.h` must also be `#included` in any application or header files that directly reference the driver (for example, by registering the device driver). The following directory must be on the project include path:

- `\Micrium\Software\uC-FS\Dev\MSC`

Before `uC/FS` is initialized, the `uC/USB` host stack must be initialized as shown in Listing 15-1. The file system initialization function (`FS_Init()`) must then be called and the MSC driver, `FSDev_MSC`, registered (using `FS_DrvAdd()`). The USB notification function should add/remove devices when events occur, as shown in Listing 15-1.

ROM/RAM characteristics and performance benchmarks of the MSC driver can be found in section 9-1-1 “Driver Characterization” on page 113.

```
static void App_InitUSB_Host (void)
{
    USBH_ERR err;
    err = USBH_HostCreate(&App_USB_Host, &USBH_AT91SAM9261_Drv);
    if (err != USBH_ERR_NONE) {
        return;
    }
    err = USBH_HostInit(&App_USB_Host);
    if (err != USBH_ERR_NONE) {
        return;
    }
    USBH_ClassDrvReg(&App_USB_Host, &USBH_MSC_ClassDrv,
                    (USBH_CLASS_NOTIFY_FNCT)App_USB_HostMSC_ClassNotify, (void *)0);
}
```

Listing 15-1 Example `uC/USB` initialization



```

static void App_USB_HostMSC_ClassNotify (void      *pclass_dev,
                                         CPU_INT08U is_conn,
                                         void      *pctx)
{
    USBH_MSC_DEV *p_msc_dev;
    USBH_ERR      usb_err;
    FS_ERR        fs_err;
    p_msc_dev = (USBH_MSC_DEV *)pclass_dev;
    switch (is_conn) {
        case USBH_CLASS_DEV_STATE_CONNECTED: /* ----- MASS STORAGE DEVICE CONN'D ----- */
            usb_err = USBH_MSC_RefAdd(p_msc_dev);
            if (usb_err == USBH_ERR_NONE) {
                FSDev_MSC_DevOpen(p_msc_dev, &fs_err);
            }
            break;
        case USBH_CLASS_DEV_STATE_REMOVED: /* ----- MASS STORAGE DEVICE REMOVED ----- */
            FSDev_MSC_DevClose(p_msc_dev);
            USBH_MSC_RefRel(p_msc_dev);
            break;
        default:
            break;
    }
}

```

Listing 15-2 μ C/USB MSC notification function

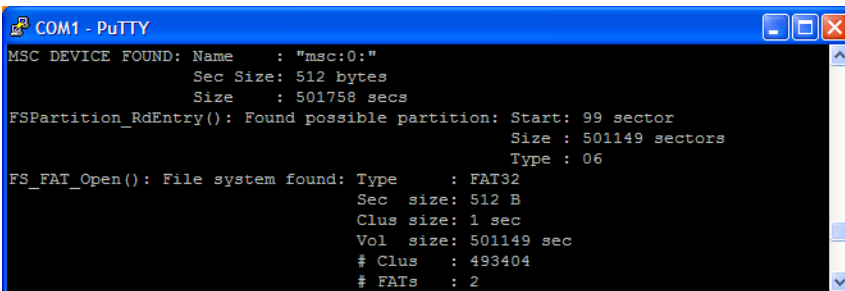
If the file system and USB stack initialization succeed, the file system will produce the trace output as shown in Figure 15-1 (if a sufficiently high trace level is configured) when the a MSC device is connected. See section E-9 “Trace Configuration” on page 507 about configuring the trace level.



```

COM1 - PuTTY
MSC DEVICE FOUND: Name      : "msc:0:"
                   Sec Size: 512 bytes
                   Size     : 501758 secs
FSPartition_RdEntry(): Found possible partition: Start: 99 sector
                                                Size : 501149 sectors
                                                Type : 06
FS_FAT_Open(): File system found: Type       : FAT32
                                   Sec size: 512 B
                                   Clus size: 1 sec
                                   Vol size: 501149 sec
                                   # Clus   : 493404
                                   # FATs   : 2

```

Figure 15-1 MSC detection trace output

A

μC/FS API Reference

This chapter provides a reference to μC/FS services. The following information is provided for each entry:

- A brief description of the service
- The function prototype
- The filename of the source code
- The #define constant required to enable code for the service
- A description of the arguments passed to the function
- A description of returned value(s)
- Specific notes and warnings regarding use of the service
- One or two examples of how to use the function

Many functions return error codes. These error codes should be checked by the application to ensure that the μC/FS function performed its operation as expected.

Each of the user-accessible file system services is presented in alphabetical order within an appropriate section; the section for a particular function can be determined from its name.

Section	Functions begin with...
General file system functions	FS_
POXIX API functions	fs_
Device functions	FSDev_
Directory functions	FSDir_
Entry functions	FSEntry_
File functions	FSFile_
Time functions	FSTime_
Volume functions	FSVol_
RAMDisk driver functions	FSDev_RAM_
NAND driver functions	FS_NAND
SD/MMC driver functions	FSDev_SD_
NAND driver functions	FSDev_NAND_
NOR driver functions	FSDev_NOR_
MSC driver functions	FSDev_MSC_
FAT functions	FS_FAT_
BSP functions	FS_BSP_
OS functions	FS_OS_

A-1 GENERAL FILE SYSTEM FUNCTIONS

```
void
FS_DevDrvAdd (FS_DEV_API *p_dev_api,
              FS_ERR      *p_err);
```

```
FS_ERR
FS_Init      (FS_CFG      *p_fs_cfg);
```

```
CPU_INT08U
FS_VersionGet (void);
```

```
void
FS_WorkingDirGet (CPU_CHAR *path_dir,
                  CPU_SIZE_T len_max,
                  FS_ERR    *p_err);
```

```
void
FS_WorkingDirSet (CPU_CHAR *path_dir,
                  FS_ERR    *p_err);
```

```
void
FS_DevDrvAdd (FS_DEV_API *p_dev_drv,
              FS_ERR      *p_err);
```

A-1-1 FS_DevDrvAdd()

```
void FS_DevDrvAdd (FS_DEV_API *p_dev_drv,
                  FS_ERR *p_err);
```

File	Called from	Code enabled by
fs.c	Application	N/A

Adds a device driver to the file system.

ARGUMENTS

p_dev_drv Pointer to device driver (see Section C.08).

p_err Pointer to variable that will receive the return error code from this function:

FS_ERR_NONE	Device driver added.
FS_ERR_NULL_PTR	Argument p_dev_drv passed a NULL pointer.
FS_ERR_DEV_DRV_ALREADY_ADDED	Device driver already added.
FS_ERR_DEV_DRV_INVALID_NAME	Device driver name invalid.
FS_ERR_DEV_DRV_NO_TBL_POS_AVAIL	No device driver table position available.

RETURNED VALUE

None.

NOTES/WARNINGS

- The **NameGet()** device driver interface function MUST return a valid name:
 - The name must be unique (e.g., a name that is not returned by any other device driver);
 - The name must NOT include any of the characters: ':', '\', or '/';
 - The name must contain fewer than **FS_CFG_MAX_DEV_DRV_NAME_LEN** characters;
 - The name must NOT be an empty string.
- The **Init()** device driver interface function is called to initialize driver structures and any hardware for detecting the presence of devices (for a removable medium).

A-1-2 FS_Init()

FS_ERR FS_Init (FS_CFG *p_fs_cfg);

File	Called from	Code enabled by
fs.h	Application	N/A

Initializes μ C/FS and MUST be called prior to calling any other μ C/FS API functions.

ARGUMENTS

`p_fs_cfg` Pointer to file system configuration (see Section C.01).

RETURNED VALUE

FS_ERR_NONE, if successful;

Specific initialization error code, otherwise.

The return value SHOULD be inspected to determine whether μ C/FS is successfully initialized or not. If μ /FS did NOT successfully initialize, search for the returned error in fs_err.h and source files to locate where μ C/FS initialization failed.

NOTES/WARNINGS

μ C/LIB memory management function `Mem_Init()` MUST be called prior to calling this function.

A-1-3 FS_VersionGet()

CPU_INT16U FS_VersionGet (void);

File	Called from	Code enabled by
fs.c	Application	N/A

Gets the μ C/FS software version.

ARGUMENTS

None.

RETURNED VALUE

μ C/FS software version.

NOTES/WARNINGS

The value returned is multiplied by 100. For example, version 4.03 would be returned as 403.

A-1-4 FS_WorkingDirGet()

```
void FS_WorkingDirGet (CPU_CHAR    *path_dir,  
                      CPU_SIZE_T  size,  
                      FS_ERR      *p_err);
```

File	Called from	Code enabled by
fs.c	Application; fs_getcwd()	FS_CFG_WORKING_DIR_EN

Get the working directory for the current task.

ARGUMENTS

path_dir String buffer that will receive the working directory path.

size Size of string buffer.

p_err Pointer to variable that will receive the return error code from this function:

FS_ERR_NONE	Working directory obtained.
FS_ERR_NULL_PTR	Argument path_dir passed a NULL pointer.
FS_ERR_NULL_ARG	Argument size passed a NULL value.
FS_ERR_NAME_BUF_TOO_SHORT	Argument size less than length of path
FS_ERR_VOL_NONE_EXIST	No volumes exist.

RETURNED VALUE

None.

NOTES/WARNINGS

If no working directory is assigned for the task, the default working directory—the root directory on the default volume—will be returned in the user buffer and set as the task's working directory.

A-1-5 FS_WorkingDirSet()

```
void FS_WorkingDirSet (CPU_CHAR *path_dir,
                      FS_ERR *p_err);
```

File	Called from	Code enabled by
fs.c	Application; fs_chdir()	FS_CFG_WORKING_DIR_EN

Set the working directory for the current task.

ARGUMENTS

path_dir String buffer that specified EITHER...

- (a) the absolute working directory path to set;
- (b) a relative path that will be applied to the current working directory.

p_err Pointer to variable that will receive the return error code from this function:

FS_ERR_NONE	Working directory set.
FS_ERR_NAME_NULL	Argument path_dir passed a NULL pointer.
FS_ERR_VOL_NONE_EXIST	No volumes exist.
FS_ERR_WORKING_DIR_NONE_AVAIL	No working directories available.
FS_ERR_WORKING_DIR_INVALID	Argument path_dir passed an invalid directory.

RETURNED VALUE,

None.

NOTES/WARNINGS

None.

A-2 POSIX API FUNCTIONS

char *		
fs_asctime_r	(const struct fs_tm *p_time, char *str_time);	
int		
fs_chdir	(const char *path_dir);	
void		
fs_clearerr	(FS_FILE *p_file);	
int		
fs_closedir	(FS_DIR *p_dir);	
char *		
fs_ctime_r	(const fs_time_t *p_ts, char *str_time);	
int		
fs_fclose	(FS_FILE *p_file);	
int		
fs_feof	(FS_FILE *p_file);	
int		
fs_ferror	(FS_FILE *p_file);	
int		
fs_fflush	(FS_FILE *p_file);	
int		
fs_fgetpos	(FS_FILE *p_file, fs_fpos_t *p_pos);	
void		
fs_flockfile	(FS_FILE *p_file);	
FS_FILE *		
fs_fopen	(const char *name_full, const char *str_mode);	

```
fs_size_t
fs_fread      (void          *p_dest,
               fs_size_t     size,
               fs_size_t     nitems,
               FS_FILE        *p_file);

int
fs_fseek      (FS_FILE        *p_file,
               long int       offset,
               int            origin);

int
fs_fsetpos    (FS_FILE        *p_file,
               fs_fpos_t      *p_pos);

long int
fs_ftell      (FS_FILE        *p_file);

int
fs_ftruncate  (FS_FILE        *p_file,
               fs_off_t       size);

int
fs_ftrylockfile (FS_FILE        *p_file);

void
fs_funlockfile (FS_FILE        *p_file);

fs_size_t
fs_fwrite     (void          *p_src,
               fs_size_t     size,
               fs_size_t     nitems,
               FS_FILE        *p_file);

char *
fs_getcwd     (char          *path_dir,
               fs_size_t     size);

struct fs_tm *
fs_localtime_r (const fs_time_t *p_ts,
                struct fs_tm      *p_time);
```

```

int
fs_mkdir      (const char      *name_full);
-----
fs_time_t
fs_mktime     (struct fs_tm     *p_time);
-----
FS_DIR *
fs_opendir    (const char      *name_full);
-----
int
fs_readdir    (FS_DIR          *p_dir,
               struct fs_dirent *p_dir_entry,
               struct fs_dirent **pp_result);
-----
int
fs_remove     (const char      *name_full);
-----
int
fs_rename     (const char      *name_full_old,
               const char      *name_full_new);
-----
void
fs_rewind     (FS_FILE         *p_file);
-----
int
fs_setbuf     (FS_FILE         *p_file,
               fs_size_t       size);
-----
int
fs_setvbuf    (FS_FILE         *p_file,
               char             *p_buf,
               int              mode,
               fs_size_t       size);

```

A-2-1 fs_asctime_r()

```
char *fs_asctime_r (const struct fs_tm *p_time,  
                    char *str_time);
```

File	Called from	Code enabled by
fs_api.c	Application	FS_CFG_API_EN

Converts date/time to string in the form:

```
Sun Sep 16 01:03:52 1973\n\0
```

ARGUMENTS

p_time Pointer to date/time to format.

str_time String buffer that will receive date/time string (see Note).

RETURNED VALUE

Pointer to **str_time**, if NO errors.

Pointer to NULL, otherwise.

NOTES/WARNINGS

str_time MUST be at least 26 characters long. Buffer overruns MUST be prevented by caller.

A-2-2 fs_chdir()

```
int fs_chdir (const char *path_dir);
```

File	Called from	Code enabled by
fs_api.c	Application	FS_CFG_API_EN and FS_CFG_WORKING_DIR_EN

Set the working directory for the current task.

ARGUMENTS

path_dir String buffer that specifies EITHER...

- the absolute working directory path to set;
- relative path that will be applied to the current working directory.

RETURNED VALUE

0, if no error occurs.

-1, otherwise

NOTES/WARNINGS

None.

A-2-3 fs_clearerr()

```
void fs_clearerr (FS_FILE *p_file);
```

File	Called from	Code enabled by
fs_api.c	Application	FS_CFG_API_EN

Clear EOF and error indicators on a file.

ARGUMENTS

p_file Pointer to a file.

RETURNED VALUE

None.

NOTES/WARNINGS

None.

A-2-4 fs_closedir()

```
int fs_closedir (FS_DIR *p_dir);
```

File	Called from	Code enabled by
fs_api.c	Application	FS_CFG_API_EN and FS_CFG_DIR_EN

Close and free a directory.

ARGUMENTS

p_dir Pointer to a directory.

RETURNED VALUE

0, if the directory is successfully closed.

-1, if any error was encountered.

NOTES/WARNINGS

After a directory is closed, the application **MUST** desist from accessing its directory pointer. This could cause file system corruption, since this handle may be re-used for a different directory.

A-2-5 fs_ctime_r()

```
char *fs_ctime_r (const fs_time_t *p_ts,  
                  char *str_time);
```

File	Called from	Code enabled by
fs_api.c	Application	FS_CFG_API_EN

Converts timestamp to string in the form:

```
Sun Sep 16 01:03:52 1973\n\0
```

ARGUMENTS

p_ts Pointer to timestamp to format.

str_time String buffer that will receive date/time string (see Note).

RETURNED VALUE

Pointer to str_time, if NO errors.

Pointer to NULL, otherwise.

NOTES/WARNINGS

str_time MUST be at least 26 characters long. Buffer overruns MUST be prevented by caller.

A-2-6 fs_fclose()

```
int fs_fclose (FS_FILE *p_file);
```

File	Called from	Code enabled by
fs_api.c	Application	FS_CFG_API_EN

Close and free a file.

ARGUMENTS

p_file Pointer to a file.

RETURNED VALUE

0, if the file was successfully closed.

FS_EOF, otherwise.

NOTES/WARNINGS

- After a file is closed, the application MUST desist from accessing its file pointer. This could cause file system corruption, since this handle may be re-used for a different file.
- If the most recent operation is output (write), all unwritten data is written to the file.
- Any buffer assigned with `fs_setbuf()` or `fs_setvbuf()` shall no longer be accessed by the file system and may be re-used by the application.

A-2-7 fs_feof()

```
int fs_feof (FS_FILE *p_file);
```

File	Called from	Code enabled by
fs_api.c	Application	FS_CFG_API_EN

Test EOF indicator on a file.

ARGUMENTS

p_file Pointer to a file.

RETURNED VALUE

0, if EOF indicator is NOT set or if an error occurred

Non-zero value, if EOF indicator is set.

NOTES/WARNINGS

- The return value from this function should ALWAYS be tested against 0:

```
rtn = fs_feof(p_file);
if (rtn == 0) {
    // EOF indicator is NOT set
} else {
    // EOF indicator is set
}
```

- If the end-of-file indicator is set (i.e., `fs_feof()` returns `DEF_YES`), `fs_clearerr()` can be used to clear that indicator.

A-2-8 fs_ferror()

```
int fs_ferror (FS_FILE *p_file);
```

File	Called from	Code enabled by
fs_api.c	Application	FS_CFG_API_EN

Test error indicator on a file.

ARGUMENTS

p_file Pointer to a file.

RETURNED VALUE

0, if error indicator is NOT set or if an error occurred

Non-zero value, if error indicator is set.

NOTES/WARNINGS

- The return value from this function should ALWAYS be tested against 0:

```
rtn = fs_ferror(p_file);
if (rtn == 0) {
    // Error indicator is NOT set
} else {
    // Error indicator is set
}
```

- If the error indicator is set (i.e., **fs_ferror()** returns a non-zero value), **fs_clearerr()** can be used to clear that indicator.

A-2-9 fs_fflush()

```
int fs_fflush (FS_FILE *p_file);
```

File	Called from	Code enabled by
fs_api.c	Application	FS_CFG_API_EN and FS_CF_FILE_BUF_EN

Flush buffer contents to file.

ARGUMENTS

p_file Pointer to a file.

RETURNED VALUE

0, if flushing succeeds.

FS_EOF, otherwise.

NOTES/WARNINGS

- If the most recent operation is output (write), all unwritten data is written to the file.
- If the most recent operation is input (read), all buffered data is cleared.

A-2-10 fs_fgetpos()

```
int fs_fgetpos (FS_FILE *p_file,  
               fs_fpos_t *p_pos);
```

File	Called from	Code enabled by
fs_api.c	Application	FS_CFG_API_EN

Get file position indicator.

ARGUMENTS

p_file Pointer to a file.

p_pos Pointer to variable that will receive the file position indicator.

RETURNED VALUE

0, if no error occurs.

Non-zero value, otherwise.

NOTES/WARNINGS

- The return value should be tested against 0:

```
rtn = fs_fgetpos(p_file, &pos);  
if (rtn == 0) {  
    // No error occurred  
} else {  
    // Handle error  
}
```

- The value placed in pos should be passed to **FS_fsetpos()** to reposition the file to its position at the time when this function was called.

A-2-11 fs_flockfile()

```
void fs_flockfile (FS_FILE *p_file);
```

File	Called from	Code enabled by
fs_api.c	Application	FS_CFG_API_EN and FS_CFG_FILE_LOCK_EN

Acquire task ownership of a file.

ARGUMENTS

p_file Pointer to a file.

RETURNED VALUE

None.

NOTES/WARNINGS

A lock count is associated with each file:

- The file is unlocked when the lock count is zero.
- If the lock count is positive, a task owns the file.
- When `fs_flockfile()` is called, if...
 - ...the lock count is zero OR
 - ...the lock count is positive and the caller owns the file...
 - ...the lock count will be incremented and the caller will own the file. Otherwise, the caller will wait until the lock count returns to zero.
- Each call to `fs_funlockfile()` decrements the lock count.
- Matching calls to `fs_flockfile()` (or `fs_ftrylockfile()`) and `fs_funlockfile()` can be nested.

A-2-12 fs_fopen()

```
FS_FILE *fs_fopen (const char *name_full,  
                  const char *str_mode);
```

File	Called from	Code enabled by
fs_api.c	Application	FS_CFG_API_EN

Open a file.

ARGUMENTS

name_full Name of the file. See section 4-3 “ μ C/FS File and Directory Names and Paths” on page 62 for information about file names.

str_mode Access mode of the file.

RETURNED VALUE

Pointer to a file, if NO errors.

Pointer to NULL, otherwise.

NOTES/WARNINGS

- The access mode should be one of the strings shown in section Table 6-2 “fopen() mode strings and mode equivalents” on page 86.
- The character ‘b’ has no effect.
- Opening a file with read mode fails if the file does not exist.
- Opening a file with append mode causes all writes to be forced to the end-of-file.

A-2-13 fs_fread()

```
fs_size_t fs_fread (void      *p_dest,  
                   fs_size_t  size,  
                   fs_size_t  nitems,  
                   FS_FILE    *p_file);
```

File	Called from	Code enabled by
fs_api.c	Application	FS_CFG_API_EN

Read from a file.

ARGUMENTS

p_dest Pointer to destination buffer.

size Size of each item to read.

nitems Number of items to read.

p_file Pointer to a file.

RETURNED VALUE

Number of items read.

NOTES/WARNINGS

- The size or nitems is 0, then the file is unchanged and zero is returned.
- If the file is buffered and the last operation is output (write), then a call to `fs_flush()` or `fs_fsetpos()` or `fs_fseek()` MUST occur before input (read) can be performed.
- The file must have been opened in read or update (read/write) mode.

A-2-14 fs_fseek()

```
int fs_fseek (FS_FILE *p_file,  
             long int  offset,  
             int       origin);
```

File	Called from	Code enabled by
fs_api.c	Application; fs_frewind()	FS_CFG_API_EN

Set file position indicator.

ARGUMENTS

p_file Pointer to a file.

offset Offset from the file position specified by whence.

origin Reference position for offset:

FS_SEEK_SET	Offset is from the beginning of the file.
FS_SEEK_CUR	Offset is from the current file position.
FS_SEEK_END	Offset is from the end of the file.

RETURNED VALUE

0, if the function succeeds.

-1, otherwise.

NOTES/WARNINGS

- If a read or write error occurs, the error indicator shall be set.
- The new file position, measured in bytes from the beginning of the file, is obtained by adding offset to...:
 - ...0 (the beginning of the file), if whence is `FS_SEEK_SET`;
 - ...the current file position, if whence is `FS_SEEK_CUR`;
 - ...the file size, if whence is `FS_SEEK_END`;
- The end-of-file indicator is cleared.
- If the file position indicator is set beyond the file's current data...
 - ...and data is later written to that point, reads from the gap will read 0.
 - ...the file MUST be opened in write or read/write mode.

A-2-15 fs_fsetpos()

```
int fs_fsetpos (FS_FILE *p_file,  
               fs_fpos_t *p_pos);
```

File	Called from	Code enabled by
fs_api.c	Application	FS_CFG_API_EN

Set file position indicator.

ARGUMENTS

p_file Pointer to a file.

p_pos Pointer to variable containing file position indicator.

RETURNED VALUE

0, if the function succeeds.

Non-zero value, otherwise.

NOTES/WARNINGS

- The return value should be tested against 0:

```
rtn = fs_fsetpos(pfile, &pos);  
if (rtn == 0) {  
    // No error occurred  
} else {  
    // Handle error  
}
```

- If a read or write error occurs, the error indicator shall be set.
- The value stored in pos should be the value from an earlier call to `fs_fgetpos()`. No attempt is made to verify that the value in pos was obtained by a call to `fs_fgetpos()`.
- See also `fs_fseek()`.

A-2-16 fs_ftell()

```
long int fs_ftell (FS_FILE *p_file);
```

File	Called from	Code enabled by
fs_api.c	Application	FS_CFG_API_EN

Get file position indicator.

ARGUMENTS

p_file Pointer to a file.

RETURNED VALUE

The current file system position, if the function succeeds.

-1, otherwise.

NOTES/WARNINGS

The file position returned is measured in bytes from the beginning of the file.

A-2-17 fs_ftruncate()

```
int fs_ftruncate (FS_FILE *p_file,  
                 fs_off_t size);
```

File	Called from	Code enabled by
fs_api.c	Application	FS_CFG_API_EN and not FS_CFG_RD_ONLY_EN

Truncate a file.

ARGUMENTS

p_file Pointer to a file.

size Size of the file after truncation

RETURNED VALUE

0, if the function succeeds.

-1, otherwise.

NOTES/WARNINGS

- The file MUST be opened in write or read/write mode.
- If **fs_ftruncate()** succeeds, the size of the file shall be equal to length.
 - If the size of the file was previously greater than length, the extra data shall no longer be available.
 - If the file previously was smaller than this length, the size of the file shall be increased.
- If the file position indicator before the call to **fs_ftruncate()** lay in the extra data destroyed by the function, then the file position will be set to the end-of-file.

A-2-18 fs_ftrylockfile()

```
int fs_ftrylockfile (FS_FILE *p_file);
```

File	Called from	Code enabled by
fs_api.c	Application	FS_CFG_API_EN and FS_CFG_FILE_LOCK_EN

Acquire task ownership of a file (if available).

ARGUMENTS

p_file Pointer to a file.

RETURNED VALUE

0, if no error occurs and the file lock is acquired.

Non-zero value, otherwise.

NOTES/WARNINGS

fs_ftrylockfile() is the non-blocking version of **fs_flockfile()**; if the lock is not available, the function returns an error.

See **fs_flockfile()**.

A-2-19 fs_funlockfile()

```
void fs_funlockfile (FS_FILE *p_file);
```

File	Called from	Code enabled by
fs_api.c	Application	FS_CFG_API_EN and FS_CFG_FILE_LOCK_EN

Release task ownership of a file.

ARGUMENTS

p_file Pointer to a file.

RETURNED VALUE

None.

NOTES/WARNINGS

See `fs_flockfile()`.

A-2-20 fs_fwrite()

```
fs_size_t fs_fwrite (void      *p_src,
                    fs_size_t  size,
                    fs_size_t  nitems,
                    FS_FILE    *p_file);
```

File	Called from	Code enabled by
fs_api.c	Application	FS_CFG_API_EN and not FS_CFG_RD_ONLY_EN

Write to a file.

ARGUMENTS

- p_src** Pointer to source buffer.
- size** Size of each item to write.
- nitems** Number of items to write.
- p_file** Pointer to a file.

RETURNED VALUE

Number of items written.

NOTES/WARNINGS

- The size or nitems is 0, then the file is unchanged and zero is returned.
- If the file is buffered and the last operation is input (read), then a call to **fs_fsetpos()** or **fs_fseek()** MUST occur before output (write can be performed unless the end-of-file was encountered).
- The file must have been opened in write or update (read/write) mode.
- If the file was opened in append mode, all writes are forced to the end-of-file.

A-2-21 fs_getcwd()

```
char *fs_getcwd (char *path_dir,  
                 fs_size_t size)
```

File	Called from	Code enabled by
fs_api.c	Application	FS_CFG_API_EN and not FS_CFG_WORKING_DIR_EN

Get the working directory for the current task.

ARGUMENTS

path_dir String buffer that will receive the working directory path.

size Size of string buffer.

RETURNED VALUE

Pointer to path_dir, if no error occurs.

Pointer to NULL, otherwise

NOTES/WARNINGS

None.

A-2-22 fs_localtime_r()

```
struct fs_tm *fs_localtime_r (const fs_time_t *p_ts,  
                             struct fs_tm *p_time);
```

File	Called from	Code enabled by
fs_api.c	Application	FS_CFG_API_EN

Convert timestamp to date/time.

ARGUMENTS

p_ts Pointer to time value.

p_time Pointer to variable that will receive broken-down time.

RETURNED VALUE

Pointer to p_time, if NO errors.

Pointer to NULL, otherwise.

NOTES/WARNINGS

None.

A-2-23 fs_mkdir()

```
int fs_mkdir (const char *name_full);
```

File	Called from	Code enabled by
fs_api.c	Application	FS_CFG_API_EN and not FS_CFG_RD_ONLY_EN

Create a directory.

ARGUMENTS

`name_full` Name of the directory.

RETURNED VALUE

0, if the directory is created.

-1, if the directory is NOT created.

NOTES/WARNINGS

None.

EXAMPLE

```
void App_Funct (void)
{
    int err;
    .
    .
    .
    err = fs_mkdir("sd:0:\\data\\old");          /* Make dir. */
    if (err != 0) {
        APP_TRACE_INFO("Could not make dir.");
    }
    .
    .
    .
}
```

A-2-24 fs_mktime()

```
fs_time_t fs_mktime (struct fs_tm *p_time);
```

File	Called from	Code enabled by
fs_api.c	Application	FS_CFG_API_EN

Convert date/time to timestamp.

ARGUMENTS

`p_time` Pointer to date/time to convert.

RETURNED VALUE

Time value, if NO errors.

`(fs_time_t)-1`, otherwise.

NOTES/WARNINGS

None.

A-2-25 fs_opendir()

```
FS_DIR *fs_opendir (const char *name_full);
```

File	Called from	Code enabled by
fs_api.c	Application	FS_CFG_API_EN and FS_CFG_DIR_EN

Open a directory.

ARGUMENTS

name_full Name of the directory. See section 4-3 “ μ C/FS File and Directory Names and Paths” on page 62 for information about directory names.

RETURNED VALUE

Pointer to a directory, if NO errors.

Pointer to NULL, otherwise.

NOTES/WARNINGS

None.

A-2-26 fs_readdir_r()

```
int fs_readdir (FS_DIR          *p_dir,
               struct fs_dirent *p_dir_entry,
               struct fs_dirent **pp_result);
```

File	Called from	Code enabled by
fs_api.c	Application	FS_CFG_API_EN and FS_CFG_DIR_EN

Read a directory entry from a directory.

ARGUMENTS

p_dir Pointer to a directory.

p_dir_entry Pointer to variable that will receive directory entry information.

pp_result Pointer to variable that will receive:

- **p_dir_entry**, if NO error occurs AND directory does not encounter EOF.
- pointer to NULL if an error occurs OR directory encounters EOF.

RETURNED VALUE

1, if an error occurs.
0, otherwise.

NOTES/WARNINGS

- Entries for “dot” (current directory) and “dot-dot” (parent directory) shall be returned, if present. No entry with an empty name shall be returned.
- If an entry is removed from or added to the directory after the directory has been opened, information may or may not be returned for that entry.

A-2-27 fs_remove()

```
int fs_remove (const char *name_full);
```

File	Called from	Code enabled by
fs_api.c	Application	FS_CFG_API_EN and not FS_CFG_RD_ONLY_EN

Delete a file or directory.

ARGUMENTS

`name_full` Name of the entry.

RETURNED VALUE

0, if the file is NOT removed.

-1, if the file is NOT removed.

NOTES/WARNINGS

- When a file is removed, the space occupied by the file is freed and shall no longer be accessible.
- A directory can be removed only if it is an empty directory.
- The root directory cannot be removed.

EXAMPLE

```
void App_Funct (void)
{
    int err;
    .
    .
    .
    err = fs_remove("sd:0:\\data\\file001.txt"); /* Remove file. */
    if (err != 0) {
        APP_TRACE_INFO("Could not remove file.");
    }
    .
    .
    .
    err = fs_remove("sd:0:\\data\\old");          /* Remove dir. */
    if (err != 0) {
        APP_TRACE_INFO("Could not remove dir.");
    }
    .
    .
    .
}
```

A-2-28 fs_rename()

```
int fs_rename (const char *name_full_old,  
              const char *name_full_new);
```

File	Called from	Code enabled by
fs_api.c	Application	FS_CFG_API_EN and not FS_CFG_RD_ONLY_EN

Rename a file or directory.

ARGUMENTS

`name_full_old` Old name of the entry.

`name_full_new` New name of the entry.

RETURNED VALUE

0, if the entry is NOT renamed.

-1, if the entry is NOT renamed.

NOTES/WARNINGS

- `name_full_old` and `name_full_new` MUST specify entries on the same volume.
- If `path_old` and `path_new` specify the same entry, the volume will not be modified and no error will be returned.
- If `path_old` specifies a file:
 - `path_new` must NOT specify a directory;
 - if `path_new` is a file, it will be removed.
- If `path_old` specifies a directory:
 - `path_new` must NOT specify a file

- if `path_new` is a directory, `path_new` MUST be empty; if so, it will be removed.
- The root directory may NOT be renamed.

EXAMPLE

```
void App_Funct (void)
{
    int err;
    .
    .
    .
    err = fs_rename("sd:0:\\data\\file001.txt", /* See Note #1. */
                  /* Rename file. */
                  "sd:0:\\data\\old\\file001.txt");
    if (err != 0) {
        APP_TRACE_INFO("Could not rename file.");
    }
    .
    .
    .
}
```

L4-6(1) For this example file rename to succeed, the following must be true when the function is called:

- The file `sd:0:\data\file001.txt` must exist.
- The directory `sd:0:\data\old` must exist.
- If `sd:0:\data\old\file001.txt` exists, it must not be read-only.

If `sd:0:\data\old\file001.txt` exists and is not read-only, it will be removed and `sd:0:\data\file001.txt` will be renamed.

A-2-29 fs_rewind()

```
void fs_rewind (FS_FILE *p_file);
```

File	Called from	Code enabled by
fs_api..c	Application	FS_CFG_API_EN

Reset file position indicator of a file.

ARGUMENTS

`p_file` Pointer to a file.

RETURNED VALUE

None.

NOTES/WARNINGS

- `fs_rewind()` is equivalent to

```
(void)fs_fseek(p_file, 0, FS_SEEK_SET)
```

except that it also clears the error indicator of the file.

A-2-30 fs_rmdir()

```
int fs_rmdir (const char *name_full);
```

File	Called from	Code enabled by
fs_api.c	Application	FS_CFG_API_EN and not FS_CFG_RD_ONLY_EN

Delete a directory.

ARGUMENTS

`name_full` Name of the file.

RETURNED VALUE

0, if the directory is removed.

-1, if the directory is NOT removed.

NOTES/WARNINGS

- A directory can be removed only if it is an empty directory.
- The root directory cannot be removed.

EXAMPLE

```
void App_Funct (void)
{
    int err;
    .
    .
    .
    err = fs_rmdir("sd:0:\\data\\old");          /* Remove dir. */
    if (err != 0) {
        APP_TRACE_INFO(("Could not remove dir.));
    }
    .
    .
    .
}
```

A-2-31 fs_setbuf()

```
int fs_setbuf (FS_FILE *p_file,  
              char *p_buf);
```

File	Called from	Code enabled by
fs_api.c	Application	FS_CFG_API_EN and FS_CFG_FILE_BUF_EN

Assign buffer to a file.

ARGUMENTS

p_file Pointer to a file.

p_buf Pointer to a buffer of FS_BUFSIZ bytes.

RETURNED VALUE

-1, if an error occurs.

0, if no error occurs.

NOTES/WARNINGS

`fs_setbuf()` is equivalent to `fs_setvbuf()` invoked with `FS__IOFBF` for mode and `FS_BUFSIZE` for size.

A-2-32 fs_setvbuf()

```
int fs_setvbuf (FS_FILE *p_file,
               char *p_buf,
               int mode,
               fs_size_t size);
```

File	Called from	Code enabled by
fs_api.c	Application	FS_CFG_API_EN and FS_CFG_FILE_BUF_EN

Assign buffer to a file.

ARGUMENTS

p_file Pointer to a file.

p_buf Pointer to buffer.

mode Buffer mode:

FS__IONBR

Unbuffered.

FS__IOFBF

Fully buffered.

size

Size of buffer, in octets.

RETURNED VALUE

-1, if an error occurs.

0, if no error occurs.

NOTES/WARNINGS

- `fs_setvbuf()` MUST be used after a stream is opened but before any other operation is performed on stream.
- `size` MUST be more than or equal to the size of one sector; it will be rounded DOWN to the nearest size of a multiple of full sectors.
- Once a buffer is assigned to a file, a new buffer may not be assigned nor may the assigned buffer be removed. To change the buffer, the file should be closed and re-opened.
- Upon power loss, any data stored in file buffers will be lost.

A-3 DEVICE FUNCTIONS

Most device access functions can return any of the following device errors:

FS_ERR_DEV_INVALID_LOW_FMT	Device needs to be low-level formatted.
FS_ERR_DEV	Device access error.
FS_ERR_DEV_IO	Device I/O error.
FS_ERR_DEV_NOT_OPEN	Device is not open.
FS_ERR_DEV_NOT_PRESENT	Device is not present.
FS_ERR_DEV_TIMEOUT	Device timeout error.

Each of these indicates that the state of the device is not suitable for the intended operation.

void		
FSDev_AccessLock	(CPU_CHAR CPU_INT32U FS_ERR	*name_dev, timeout, *p_err);
void		
FSDev_AccessUnlock	(CPU_CHAR FS_ERR	*name_dev, *p_err);
void		
FSDev_Close	(CPU_CHAR FS_ERR	*name_dev, *p_err);
FS_PARTITION_NBR		
FSDev_GetNbrPartitions	(CPU_CHAR FS_ERR	*name_dev, *p_err);
void		
FSDev_GetDevName	(FS_QTY CPU_CHAR	dev_nbr, *name_dev);
FS_QTY		
FSDev_GetDevCnt	(void);	
FS_QTY		
FSDev_GetDevCntMax	(void);	

void		
FSDev_Invalidate	(CPU_CHAR FS_ERR	*name_dev, *p_err);
void		
FSDev_Open	(CPU_CHAR void FS_ERR	*name_dev, *p_dev_cfg, *p_err);
FS_PARTITION_NBR		
FSDev_PartitionAdd	(CPU_CHAR FS_SEC_QTY FS_ERR	*name_dev, partition_size, *p_err);
void		
FSDev_PartitionFind	(CPU_CHAR FS_PARTITION_NBR FS_PARTITION_ENTRY FS_ERR	*name_dev, partition_nbr, *p_partition_entry, *p_err);
void		
FSDev_PartitionInit	(CPU_CHAR FS_SEC_QTY FS_ERR	*name_dev, partition_size, *p_err);
void		
FSDev_Query	(CPU_CHAR FS_DEV_INFO FS_ERR	*name_dev, *p_info, *p_err);
void		
FSDev_Rd	(CPU_CHAR void FS_SEC_NBR FS_SEC_QTY FS_ERR	*name_dev, *p_dest, start, cnt, *p_err);
CPU_BOOLEAN		
FSDev_Refresh	(CPU_CHAR FS_ERR	*name_dev, *p_err);

```
void
FSDev_Wr      (CPU_CHAR      *name_dev,
               void          *p_src,
               FS_SEC_NBR    start,
               FS_SEC_QTY    cnt,
               FS_ERR        *p_err);
```

A-3-1 FSDev_AccessLock()

```
void FSDev_AccessLock (CPU_CHAR    *name_dev,  
                      CPU_INT32U   timeout  
                      FS_ERR       *p_err);
```

File	Called from	Code enabled by
fs_dev.c	Application	N/A

Acquire exclusive access to a device. See also section 5-4 “Raw Device IO” on page 72.

ARGUMENTS

name_dev Device name.

timeout Time to wait for a lock in milliseconds.

p_err Pointer to variable that will receive return error code from this function :

FS_ERR_NONE	Device removed successfully.
FS_ERR_DEV_NOT_OPEN	Device is not open.
FS_ERR_NAME_NULL	Argument name_dev passed a NULL pointer
FS_ERR_OS_LOCK	Error acquiring device access lock.
FS_ERR_OS_LOCK_TIMEOUT	Time-out waiting for device access lock.

RETURNED VALUE

None.

NOTES/WARNINGS

None.

A-3-2 FSDev_AccessUnlock()

```
void FSDev_AccessUnlock (CPU_CHAR    *name_dev,
                        FS_ERR      *p_err);
```

File	Called from	Code enabled by
fs_dev.c	Application	N/A

Release exclusive access to a device. See also section 5-4 “Raw Device IO” on page 72.

ARGUMENTS

name_dev Device name.

p_err Pointer to variable that will receive return error code from this function :

FS_ERR_NONE	Device removed successfully.
FS_ERR_DEV_NOT_OPEN	Device is not open.
FS_ERR_NAME_NULL	Argument name_dev passed a NULL pointer

RETURNED VALUE

None.

NOTES/WARNINGS

None.

A-3-3 FSDev_Close()

```
void FSDev_Close (CPU_CHAR *name_dev,  
                 FS_ERR   *p_err);
```

File	Called from	Code enabled by
fs_dev.c	Application	N/A

Close and free a device.

ARGUMENTS

name_dev Device name.

p_err Pointer to variable that will receive return error code from this function :

FS_ERR_NONE

Device removed successfully.

FS_ERR_DEV_NOT_OPEN

Device is not open.

FS_ERR_NAME_NULL

Argument **name_dev** passed a NULL pointer

RETURNED VALUE

None.

NOTES/WARNINGS

None.

A-3-4 FSDev_GetDevName()

```
void FSDev_GetDevName (FS_QTY dev_nbr,  
                      CPU_CHAR *name_dev);
```

File	Called from	Code enabled by
fs_dev.c	Application	N/A

Get name of the *nth* open device. `dev_nbr` should be between 0 and the return value of `FSDev_GetNbrDevs()` (inclusive).

ARGUMENTS

`dev_nbr` Device number.

`name_dev` String buffer that will receive the device name (see Note #2).

RETURNED VALUE

None.

NOTES/WARNINGS

- `name_dev` *must* point to a character array of `FS_CFG_MAX_DEV_NAME_LEN` characters.
- If the device does not exist, `name_dev` will receive an empty string.

A-3-5 FSDev_GetDevCnt()

FS_QTY FSDev_GetDevCnt (void);

File	Called from	Code enabled by
fs_dev.c	Application	N/A

Gets the number of open devices.

ARGUMENTS

None.

RETURNED VALUE

Number of devices currently open.

NOTES/WARNINGS

None.

A-3-6 FSDev_GetDevCntMax()

FS_QTY FSDev_GetDevCntMax (void);

File	Called from	Code enabled by
fs_dev.c	Application	N/A

Gets the maximum possible number of open devices.

ARGUMENTS

None.

RETURNED VALUE

Maximum number of open devices.

NOTES/WARNINGS

None.

A-3-7 FSDev_GetNbrPartitions()

```
FS_PARTITION_NBR FSDev_GetNbrPartitions (CPU_CHAR *name_dev,  
                                         FS_ERR    *p_err);
```

File	Called from	Code enabled by
fs_dev.c	Application	FS_CFG_PARTITION_EN

Get number of partitions on a device

ARGUMENTS

name_dev Pointer to the device name.

p_err Pointer to variable that will receive return error code from this function.

FS_ERR_NONE	Number of partitions obtained.
FS_ERR_DEV_VOL_OPEN	Volume open on device.
FS_ERR_INVALID_SIG	Invalid MBR signature.
FS_ERR_NAME_NULL	Argument name_dev passed a NULL pointer.

Or device access error (see section B-4 “Device Error Codes” on page 394).

RETURNED VALUE

Number of partitions on the device, if no error was encountered.

Zero, otherwise.

NOTES/WARNINGS

Device state change will result from device I/O, not present or timeout error.

A-3-8 FSDev_Invalidate()

```
void FSDev_Invalidate (CPU_CHAR *name_dev,
                      FS_ERR *p_err);
```

File	Called from	Code enabled by
fs_dev.c	Application	N/A

Invalidate files and volumes opened on a device. See also section 5-4 “Raw Device IO” on page 72.

ARGUMENTS

name_dev Device name

p_err Pointer to variable that will receive return error code from this function.

FS_ERR_NONE Partition added.

FS_ERR_NAME_NULL Argument **name_dev** passed a NULL pointer.

Or device access error (see section B-4 “Device Error Codes” on page 394).

RETURNED VALUE

None.

NOTES/WARNINGS

- 1 Operations on an affected file or volume will fail with an FS_ERR_DEV_CHNGD error.
- 2 Invalidation will happen automatically following a removable media change.

A-3-9 FSDev_Open()

```
void FSDev_Open (CPU_CHAR *name_dev,  
                void      *p_dev_cfg,  
                FS_ERR    *p_err);
```

File	Called from	Code enabled by
fs_dev.c	Application	N/A

Open a device.

ARGUMENTS

name_dev Device name. See section 4-3 “ μ C/FS File and Directory Names and Paths” on page 62 for information about device names.

p_dev_cfg Pointer to device configuration.

p_err Pointer to variable that will receive the return error code from this function (see Note #2):

FS_ERR_NONE	Device opened successfully.
FS_ERR_DEV_ALREADY_OPEN	Device is already open.
FS_ERR_DEV_INVALID_LOW_FMT	Device needs to be low-level formatted.
FS_ERR_DEV_INVALID_NAME	Specified device name not valid.
FS_ERR_DEV_INVALID_SEC_SIZE	Invalid device sector size.
FS_ERR_DEV_INVALID_SIZE	Invalid device size.
FS_ERR_DEV_INVALID_UNIT_NBR	Specified unit number invalid.
FS_ERR_DEV_IO	Device I/O error.
FS_ERR_DEV_NONE_AVAIL	No devices available.
FS_ERR_DEV_NOT_PRESENT	Device is not present.
FS_ERR_DEV_TIMEOUT	Device timeout error.
FS_ERR_DEV_UNKNOWN	Unknown device error.
FS_ERR_NAME_NULL	Argument name_dev passed a NULL pointer

RETURNED VALUE

None.

NOTES/WARNINGS

The return error code from the function SHOULD always be checked by the calling application to determine whether the device was successfully opened. Repeated calls to `FSDev_Open()` resulting in errors that do not indicate failure to open (such as `FS_ERR_DEV_LOW_FMT_INVALID`) without matching `FSDev_Close()` calls may exhaust the supply of device structures.

- If `FS_ERR_NONE` is returned, then the device has been added to the file system and is immediately accessible.
- If `FS_DEV_INVALID_LOW_FMT` is returned, then the device has been added to the file system, but needs to be low-level formatted, though it is present.
- If `FS_ERR_DEV_NOT_PRESENT`, `FS_ERR_DEV_IO` or `FS_ERR_DEV_TIMEOUT` is returned, then the device has been added to the file system, though it is probably not present. The device will need to be either closed and re-added, or refreshed.
- If any of the following is returned:

```
FS_ERR_DEV_INVALID_NAME
FS_ERR_DEV_INVALID_SEC_SIZE
FS_ERR_DEV_INVALID_SIZE
FS_ERR_DEV_INVALID_UNIT_NBR
FS_ERR_DEV_NONE_AVAIL
```

...then the device has NOT been added to the file system.

- If `FS_ERR_DEV_UNKNOWN` is returned, then the device driver is in an indeterminate state. The system MAY need to be restarted and the device driver should be examined for errors. The device has NOT been added to the file system.

A-3-10 FSDev_PartitionAdd()

```
FS_PARTITION_NBR FSDev_PartitionAdd (CPU_CHAR *name_dev,  
                                     FS_SEC_QTY partition_size,  
                                     FS_ERR *p_err);
```

File	Called from	Code enabled by
fs_dev.c	Application	FS_CFG_PARTITION_EN and not FS_CFG_RD_ONLY_EN

Adds a partition to a device. See also section 5-5 “Partitions” on page 73.

ARGUMENTS

`name_dev` Device name

`partition_size` Size, in sectors, of the partition to add.

`p_err` Pointer to variable that will receive return error code from this function.

<code>FS_ERR_NONE</code>	Partition added.
<code>FS_ERR_INVALID_PARTITION</code>	Invalid partition.
<code>FS_ERR_INVALID_SEC_NBR</code>	Sector start or count invalid.
<code>FS_ERR_INVALID_SIG</code>	Invalid MBR signature.
<code>FS_ERR_NAME_NULL</code>	Argument <code>name_dev</code> passed a NULL pointer.

Or device access error (see section B-4 “Device Error Codes” on page 394).

RETURNED VALUE

The index of the created partition. The first partition on the device has an index of 0. `FS_INVALID_PARTITION_NBR` is returned if the function fails to add the partition.

NOTES/WARNINGS

Device state change will result from device I/O, not present or timeout error.

A-3-11 FSDev_PartitionFind()

```
void FSDev_PartitionFind (CPU_CHAR          *name_dev,
                        FS_PARTITION_NBR    partition_nbr,
                        FS_PARTITION_ENTRY  *p_partition_entry,
                        FS_ERR              *p_err);
```

File	Called from	Code enabled by
fs_dev.c	Application	FS_CFG_PARTITION_EN

Find a partition on a device.

See also section 5-5 “Partitions” on page 73.

ARGUMENTS

name_dev Device name.

partition_nbr Index of the partition to find.

p_partition_entry Pointer to variable that will receive the partition information.

p_err Pointer to variable that will receive return error code from this function.

FS_ERR_NONE	Partition found.
FS_ERR_DEV_VOL_OPEN	Volume open on device.
FS_ERR_INVALID_PARTITION	Invalid partition.
FS_ERR_INVALID_SEC_NBR	Sector start or count invalid.
FS_ERR_INVALID_SIG	Invalid MBR signature.
FS_ERR_NAME_NULL	Argument name_dev passed a NULL pointer.
FS_ERR_NULL_PTR	Argument p_partition_entry passed a NULL pointer.

Or device access error (see section B-4 “Device Error Codes” on page 394).

RETURNED VALUE

None.

NOTES/WARNINGS

Device state change will result from device I/O, not present or timeout error.

A-3-12 FSDev_PartitionInit()

```
void FSDev_PartitionInit (CPU_CHAR *name_dev,
                        FS_SEC_QTY partition_size,
                        FS_ERR *p_err);
```

File	Called from	Code enabled by
fs_dev.c	Application	not FS_CFG_RD_ONLY_EN

Initialize the partition structure on a device. See also section 5-5 “Partitions” on page 73.

ARGUMENTS

name_dev Device name.

partition_size Size of partition, in sectors. OR
0, if partition will occupy entire device.

p_err Pointer to variable that will receive the return error code from this function.

FS_ERR_NONE	Partition structure initialized.
FS_ERR_DEV_VOL_OPEN	Volume open on device.
FS_ERR_INVALID_SEC_NBR	Sector start or count invalid.
FS_ERR_NAME_NULL	Argument name_dev passed a NULL pointer.

Or device access error (see section B-4 “Device Error Codes” on page 394).

RETURNED VALUE

None.

NOTES/WARNINGS

- 1 Function blocked if a volume is open on the device. All volume (and files) *must* be closed prior to initializing the partition structure, since it will obliterate any existing file system.
- 2 Device state change will result from device I/O, not present or timeout error.

A-3-13 FSDev_Query()

```
void FSDev_Query (CPU_CHAR      *name_dev,  
                  FS_DEV_INFO  *p_info,  
                  FS_ERR        *p_err);
```

File	Called from	Code enabled by
fs_dev.c	Application	N/A

Obtain information about a device.

ARGUMENTS

name_dev Device name.

p_info Pointer to structure that will receive device information (see Note).

p_err Pointer to variable that will receive the return error code from this function:

FS_ERR_NONE	Device information obtained.
FS_ERR_NAME_NULL	Argument name_dev passed a NULL pointer.
FS_ERR_NULL_PTR	Argument p_info passed a NULL pointer.
FS_ERR_INVALID_SEC_NBR	Sector start or count invalid.

Or device access error (see section B-4 “Device Error Codes” on page 394).

RETURNED VALUE

None.

NOTES/WARNINGS

For removable medias, **FSDev_Query()** will return a valid value for the **State** and **Fixed** members of **p_info** even if the media is not present, **Size** and **SecSize** will be set to 0. In such cases an error will be returned stating the reason why the device was unaccessible. Otherwise, if a fatal error occurs or the device is not opened an appropriate error will be return and the content of **p_info** will be invalid.

A-3-14 FSDev_Rd()

```
void FSDev_Rd (CPU_CHAR    *name_dev,
              void         *p_dest,
              FS_SEC_NBR   start,D
              FS_SEC_QTY   cnt,
              FS_ERR       *p_err);
```

File	Called from	Code enabled by
fs_dev.c	Application	N/A

Read data from device sector(s). See also section 5-4 “Raw Device IO” on page 72.

ARGUMENTS

name_dev Device name.

p_dest Pointer to destination buffer.

start Start sector of read.

cnt Number of sectors to read

p_err Pointer to variable that will receive the return error code from this function

FS_ERR_NONE Sector(s) read.

FS_ERR_NAME_NULL Argument **name_dev** passed a NULL pointer.

FS_ERR_NULL_PTR Argument **p_dest** passed a NULL pointer.

Or device access error (see section B-4 “Device Error Codes” on page 394).

RETURNED VALUE

None.

NOTES/WARNINGS

Device state change will result from device I/O, not present or timeout error.

A-3-15 FSDev_Refresh()

```
CPU_BOOLEAN FSDev_Refresh (CPU_CHAR *name_dev,  
                           FS_ERR   *p_err);
```

File	Called from	Code enabled by
fs_dev.c	Application	N/A

Refresh a device. Arguments

name_dev Device name.

p_err Pointer to variable that will receive the return error code from this function.

FS_ERR_NONE	Device opened successfully.
FS_ERR_DEV_INVALID_SEC_SIZE	Invalid device sector size.
FS_ERR_DEV_INVALID_SIZE	Invalid device size.
FS_ERR_DEV_INVALID_UNIT_NBR	Specified unit number invalid.
FS_ERR_NAME_NULL	Argument name_dev passed a NULL pointer

Or device access error (see section B-4 “Device Error Codes” on page 394).

RETURNED VALUE

DEF_YES, if the device has not changed.

DEF_NO, if the device has not changed.

NOTES/WARNINGS

- If device has changed, all volumes open on the device must be refreshed and all files closed and reopened.
- A device status change may be caused by
 - A device was connected, but no longer is.
 - A device was not connected, but now is.

- A different device is connected.

A-3-16 FSDev_Wr()

```
void FSDev_Wr (CPU_CHAR   *name_dev,  
              void       *p_src,  
              FS_SEC_NBR  start,  
              FS_SEC_QTY  cnt,  
              FS_ERR      *p_err);
```

File	Called from	Code enabled by
fs_dev.c	Application	not FS_CFG_RD_ONLY_EN

Write data to device sector(s). See also section 5-4 “Raw Device IO” on page 72.

ARGUMENTS

name_dev Device name.

p_src Pointer to source buffer.

start Start sector of write.

cnt Number of sectors to write

p_err Pointer to variable that will receive the return error code from this function

FS_ERR_NONE Sector(s) written.

FS_ERR_NAME_NULL Argument **name_dev** passed a NULL pointer.

FS_ERR_NULL_PTR Argument **p_src** passed a NULL pointer.

Or device access error (see section B-4 “Device Error Codes” on page 394).

RETURNED VALUE

None.

NOTES/WARNINGS

Device state change will result from device I/O, not present or timeout error.

A-4 DIRECTORY ACCESS FUNCTIONS

```
void
FSDir_Close (FS_DIR      *p_dir,
             FS_ERR      *p_err);
```

```
CPU_BOOLEAN
FSDir_IsOpen (CPU_CHAR   *name_full,
             FS_ERR      *p_err);
```

```
FS_DIR *
FSDir_Open (CPU_CHAR   *name_full,
           FS_ERR      *p_err);
```

```
void
FSDir_Rd (FS_DIR      *p_dir,
         FS_DIR_ENTRY *p_dir_entry,
         FS_ERR      *p_err);
```

A-4-1 FSDir_Close()

```
void FSDir_Close (FS_DIR *p_dir,  
                 FS_ERR *p_err);
```

File	Called from	Code enabled by
fs_dir.c	Application; fs_closedir()	FS_CFG_DIR_EN

Close and free a directory.

See `fs_closedir()` for more information.

ARGUMENTS

`p_dir` Pointer to a directory.

`p_err` Pointer to variable that will receive return error code from this function:

<code>FS_ERR_NONE</code>	Directory closed.
<code>FS_ERR_NULL_PTR</code>	Argument <code>p_dir</code> passed a NULL pointer.
<code>FS_ERR_INVALID_TYPE</code>	Argument <code>p_dir</code> 's TYPE is invalid or unknown.
<code>FS_ERR_DIR_DIS</code>	Directory module disabled.
<code>FS_ERR_DIR_NOT_OPEN</code>	Directory NOT open.

RETURNED VALUE

None.

NOTES/WARNINGS

None.

A-4-2 FSDir_IsOpen()

```
CPU_BOOLEAN  FSDir_Open (CPU_CHAR  *name_full,
                        FS_ERR      *p_err);
```

File	Called from	Code enabled by
fs_dir.c	Application; fs_opendir(); FSEntry_*	FS_CFG_DIR_EN

Test if a directory is already open. This function is also called by various **FSEntry_*** functions to prevent concurrent access to an entry in the FAT filesystem.

ARGUMENTS

name_full Name of the directory. See section 4-3 “ μ C/FS File and Directory Names and Paths” on page 62.

p_err Pointer to variable that will the receive return error code from this function:

FS_ERR_NONE	Directory opened.
FS_ERR_NAME_NULL	Argument name_full passed a NULL pointer.
FS_ERR_NAME_INVALID	Entry name specified invalid or volume could not be found.

Or entry error (see section B-8 “Entry Error Codes” on page 395).

RETURNED VALUE

DEF_NO, if dir is NOT open.

DEF_YES, if dir is open.

NOTES/WARNINGS

None.

A-4-3 FSDir_Open()

```
FS_DIR *FSDir_Open (CPU_CHAR *name_full,  
                  FS_ERR *p_err);
```

File	Called from	Code enabled by
fs_dir.c	Application; fs_opendir()	FS_CFG_DIR_EN

Open a directory. See `fs_opendir()` for more information.

ARGUMENTS

name_full Name of the directory. See section 4-3 “ μ C/FS File and Directory Names and Paths” on page 62.

p_err Pointer to variable that will receive return error code from this function:

FS_ERR_NONE	Directory opened.
FS_ERR_NAME_NULL	Argument <code>name_full</code> passed a NULL pointer.
FS_ERR_DIR_DIS	Directory module disabled.
FS_ERR_DIR_NONE_AVAIL	No directory available.
FS_ERR_DEV	Device access error.
FS_ERR_NAME_INVALID	Entry name specified invalid or volume could not be found.
FS_ERR_NAME_PATH_TOO_LONG	Entry name is too long.
FS_ERR_VOL_NOT_OPEN	Volume not opened.
FS_ERR_VOL_NOT_MOUNTED	Volume not mounted.
FS_ERR_BUF_NONE_AVAIL	Buffer not available.

Or entry error (see section B-8 “Entry Error Codes” on page 395).

RETURNED VALUE

Pointer to a directory, if NO errors. Pointer to NULL, otherwise.

NOTES/WARNINGS

None.

A-4-4 FSDir_Rd()

```
void FSDir_Rd (FS_DIR      *p_dir,
              FS_DIR_ENTRY *p_dir_entry,
              FS_ERR      *p_err);
```

File	Called from	Code enabled by
fs_dir.c	Application; fs_readdir_r()	FS_CFG_DIR_EN

Read a directory entry from a directory. See `fs_readdir_r()` for more information.

ARGUMENTS

`p_dir` Pointer to a directory.

`p_dir_entry` Pointer to variable that will receive directory entry information.

`p_err` Pointer to variable that will receive return error code from this function:

<code>FS_ERR_NONE</code>	Directory read successfully.
<code>FS_ERR_NULL_PTR</code>	Argument <code>p_dir/p_dir_entry</code> passed a NULL pointer.
<code>FS_ERR_INVALID_TYPE</code>	Argument <code>p_dir</code> 's TYPE is invalid or unknown.
<code>FS_ERR_DIR_DIS</code>	Directory module disabled.
<code>FS_ERR_DIR_NOT_OPEN</code>	Directory NOT open.
<code>FS_ERR_EOF</code>	End of directory reached.
<code>FS_ERR_DEV</code>	Device access error.
<code>FS_ERR_BUF_NONE_AVAIL</code>	Buffer not available.

RETURNED VALUE

None.

NOTES/WARNINGS

None.

A-5 ENTRY ACCESS FUNCTIONS

void

```
FSEntry_AttribSet (CPU_CHAR      *name_full,  
                  FS_FLAGS      attrib,  
                  FS_ERR        *p_err);
```

void

```
FSEntry_Copy      (CPU_CHAR      *name_full_src,  
                  CPU_CHAR      *name_full_dest,  
                  CPU_BOOLEAN    excl,  
                  FS_ERR        *p_err);
```

void

```
FSEntry_Create    (CPU_CHAR      *name_full,  
                  FS_FLAGS      entry_type,  
                  CPU_BOOLEAN    excl,  
                  FS_ERR        *p_err);
```

void

```
FSEntry_Del      (CPU_CHAR      *name_full,  
                  FS_FLAGS      entry_type,  
                  FS_ERR        *p_err);
```

void

```
FSEntry_Query    (CPU_CHAR      *name_full,  
                  FS_ENTRY_INFO *p_info,  
                  FS_ERR        *p_err);
```

void

```
FSEntry_Rename   (CPU_CHAR      *name_full_src,  
                  CPU_CHAR      *name_full_dest,  
                  CPU_BOOLEAN    excl,  
                  FS_ERR        *p_err);
```

void

```
FSEntry_TimeSet  (CPU_CHAR      *name_full,  
                  FS_DATE_TIME  *p_time,  
                  CPU_INT08U     flag,  
                  FS_ERR        *p_err);
```

A-5-1 FSEntry_AttribSet()

```
void FSEntry_AttribSet (CPU_CHAR *name_full,
                       FS_FLAGS attrib,
                       FS_ERR *p_err);
```

File	Called from	Code enabled by
fs_entry.c	Application	not FS_CFG_RD_ONLY_EN

Set a file or directory's attributes.

ARGUMENTS

name_full Name of the entry. See section 4-3 "µC/FS File and Directory Names and Paths" on page 62.

attrib Entry attributes to set (see Note #2).

p_err Pointer to variable that will the receive return error code from this function:

FS_ERR_NONE	Entry attributes set successfully.
FS_ERR_NAME_NULL	Argument name_full passed a NULL pointer.
FS_ERR_NAME_INVALID	Entry name specified invalid OR volume could not be found.
FS_ERR_NAME_PATH_TOO_LONG	Entry name specified too long.
FS_ERR_VOL_NOT_OPEN	Volume was not open.
FS_ERR_VOL_NOT_MOUNTED	Volume was not mounted.
FS_ERR_BUF_NONE_AVAIL	Buffer not available.
FS_ERR_DEV	Device access error.

Or entry error (See section B-8 "Entry Error Codes" on page 395).

RETURNED VALUE

None.

NOTES/WARNINGS

- If the entry does not exist, an error is returned.

- Three attributes may be modified by this function:

<code>FS_ENTRY_ATTRIB_RD</code>	Entry is readable.
<code>FS_ENTRY_ATTRIB_WR</code>	Entry is writable.
<code>FS_ENTRY_ATTRIB_HIDDEN</code>	Entry is hidden from user-level processes.

An attribute will be cleared if its flag is not OR'd into `attrib`. An attribute will be set if its flag is OR'd into `attrib`. If another flag besides these are set, then an error will be returned.

- The attributes of the root directory may NOT be set.

A-5-2 FSEntry_Copy()

```
void FSEntry_Copy (CPU_CHAR      *name_full_src,
                  CPU_CHAR      *name_full_dest,
                  CPU_BOOLEAN    excl,
                  FS_ERR         *p_err);
```

File	Called from	Code enabled by
fs_entry.c	Application	not FS_CFG_RD_ONLY_EN

Copy a file.

ARGUMENTS

name_full_src Name of the source file. See section 4-3 “µC/FS File and Directory Names and Paths” on page 62.

name_full_dest Name of the destination file.

excl Indicates whether the creation of the new entry shall be exclusive
 DEF_YES, if the entry shall be copied only if **name_full_dest** does not exist.
 DEF_NO, if the entry shall be copied even if **name_full_dest** does exist.

p_err Pointer to variable that will the receive return error code from this function:

FS_ERR_NONE	File copied successfully.
FS_ERR_NAME_NULL	Argument name_full_src or name_full_dest passed a NULL pointer.
FS_ERR_NAME_INVALID	Entry name specified invalid OR volume could not be found.
FS_ERR_NAME_PATH_TOO_LONG	Entry name specified too long.
FS_ERR_VOL_NOT_OPEN	Volume was not open.
FS_ERR_VOL_NOT_MOUNTED	Volume was not mounted.
FS_ERR_BUF_NONE_AVAIL	Buffer not available.
FS_ERR_DEV	Device access error.

Or entry error (See section B-8 “Entry Error Codes” on page 395).

RETURNED VALUE

None.

NOTES/WARNINGS

- `name_full_src` must be an existing file. It may not be an existing directory.
- If `excl` is `DEF_NO`, `name_full_dest` must either not exist or be an existing file; it may not be an existing directory. If `excl` is `DEF_YES`, `name_full_dest` must not exist.

A-5-3 FSEntry_Create()

```
void FSEntry_Create (CPU_CHAR      *name_full,
                    FS_FLAGS      entry_type,
                    CPU_BOOLEAN    excl,
                    FS_ERR        *p_err);
```

File	Called from	Code enabled by
fs_entry.c	Application; fs_mkdir()	not FS_CFG_RD_ONLY_EN

Create a file or directory.

See also `fs_mkdir()`.

ARGUMENTS

name_full Name of the entry. See section 4-3 “ μ C/FS File and Directory Names and Paths” on page 62.

entry_type Indicates whether the new entry shall be a directory or a file (see Note #1) :

`FS_ENTRY_TYPE_DIR`, if the entry shall be a directory.

`FS_ENTRY_TYPE_FILE`, if the entry shall be a file.

excl Indicates whether the creation of the new entry shall be exclusive (see Notes):

`DEF_YES`, if the entry shall be created only if `p_name_full` does not exist.

`DEF_NO`, if the entry shall be created even if `p_name_full` does exist.

p_err Pointer to variable that will the receive return error code from this function:

<code>FS_ERR_NONE</code>	Entry created successfully.
<code>FS_ERR_NAME_NULL</code>	Argument <code>name_full</code> passed a NULL pointer.
<code>FS_ERR_NAME_INVALID</code>	Entry name specified invalid OR volume could not be found.
<code>FS_ERR_NAME_PATH_TOO_LONG</code>	Entry name specified too long.
<code>FS_ERR_VOL_NOT_OPEN</code>	Volume was not open.
<code>FS_ERR_VOL_NOT_MOUNTED</code>	Volume was not mounted.
<code>FS_ERR_BUF_NONE_AVAIL</code>	Buffer not available.
<code>FS_ERR_DEV</code>	Device access error. Or entry error.

RETURNED VALUE

None.

NOTES/WARNINGS

- If the entry exists and is a file, `entry_type` is `FS_ENTRY_TYPE_FILE` and `excl` is `DEF_NO`, then the existing entry will be truncated. If the entry exists and is a directory and `entry_type` is `FS_ENTRY_TYPE_DIR`, then no change will be made to the file system.
- If the entry exists and is a directory, `dir` is `DEF_NO` and `excl` is `DEF_NO`, then no change will be made to the file system. Similarly, if the entry exists and is a file, `dir` is `DEF_YES` and `excl` is `DEF_NO`, then no change will be made to the file system.
- The root directory may not be created.

A-5-4 FSEntry_Del()

```
void FSEntry_Del (CPU_CHAR      *name_full,
                  FS_FLAGS      entry_type,
                  FS_ERR        *p_err);
```

File	Called from	Code enabled by
fs_entry.c	Application; fs_rmdir(); fs_remove()	not FS_CFG_RD_ONLY_EN

Delete a file or directory.

See also `fs_remove()` and `fs_rmdir()`.

ARGUMENTS

name_full Pointer to character string representing the name of the entry. See section 4-3 “ μ C/FS File and Directory Names and Paths” on page 62.

entry_type Indicates whether the entry MAY be a file (see Notes #1 and #2):

FS_ENTRY_TYPE_DIR	if the entry must be a dir.
FS_ENTRY_TYPE_FILE	if the entry must be a file.
FS_ENTRY_TYPE_ANY	if the entry may be any type.

p_err Pointer to variable that will the receive return error code from this function:

FS_ERR_NONE	Entry date/time set successfully.
FS_ERR_NAME_NULL	Argument <code>name_full</code> passed a NULL pointer.
FS_ERR_NAME_INVALID	Entry name specified invalid OR volume could not be found.
FS_ERR_NAME_PATH_TOO_LONG	Entry name specified too long.
FS_ERR_VOL_NOT_OPEN	Volume was not open.
FS_ERR_VOL_NOT_MOUNTED	Volume was not mounted.
FS_ERR_BUF_NONE_AVAIL	Buffer not available.
FS_ERR_DEV	Device access error. Or entry error.

RETURNED VALUE

None.

NOTES/WARNINGS

- When a file is removed, the space occupied by the file is freed and shall no longer be accessible.
- A directory can be removed only if it is an empty directory.
- The root directory cannot be deleted.

A-5-5 FSEntry_Query()

```
void FSEntry_Query (CPU_CHAR      *name_full,
                   FS_ENTRY_INFO *p_info,
                   FS_ERR         *p_err);
```

File	Called from	Code enabled by
fs_entry.c	Application; fs_stat()	N/A

Get information about a file or directory.

ARGUMENTS

name_full Name of the entry. See section 4-3 “µC/FS File and Directory Names and Paths” on page 62.

p_info Pointer to structure that will receive the file information.

p_err Pointer to variable that will the receive return error code from the function:

FS_ERR_NONE	File information obtained successfully.
FS_ERR_NAME_NULL	Argument name_full passed a NULL pointer.
FS_ERR_NAME_INVALID	Entry name specified invalid OR volume could not be found.
FS_ERR_NAME_PATH_TOO_LONG	Entry name specified too long.
FS_ERR_VOL_NOT_OPEN	Volume was not open.
FS_ERR_VOL_NOT_MOUNTED	Volume was not mounted.
FS_ERR_BUF_NONE_AVAIL	Buffer not available.
FS_ERR_DEV	Device access error.

RETURNED VALUE

None.

NOTES/WARNINGS

None.

A-5-6 FSEntry_Rename()

```
void FSEntry_Rename (CPU_CHAR    *name_full_old,  
                    CPU_CHAR    *name_full_new,  
                    CPU_BOOLEAN  excl,  
                    FS_ERR      *p_err);
```

File	Called from	Code enabled by
fs_entry.c	Application; fs_rename()	not FS_CFG_RD_ONLY_EN

Rename a file or directory.

See also `fs_rename()`.

ARGUMENTS

name_full_old Old path of the entry. See section 4-3 “ μ C/FS File and Directory Names and Paths” on page 62.

name_full_new New path of the entry.

excl Indicates whether the creation of the new entry shall be exclusive (see Note #1):

DEF_YES, if the entry shall be renamed only if **name_full_new** does not exist.

DEF_NO, if the entry shall be renamed even if **name_full_new** does exist.

p_err Pointer to variable that will receive return error code from this function:

FS_ERR_NONE File copied successfully.

FS_ERR_NAME_NULL Argument **name_full_old** or **name_full_new** passed a NULL pointer.

FS_ERR_NAME_INVALID Entry name specified invalid OR volume could not be found.

FS_ERR_NAME_PATH_TOO_LONG Entry name specified too long.

FS_ERR_VOL_NOT_OPEN Volume was not open.

FS_ERR_VOL_NOT_MOUNTED Volume was not mounted.

<code>FS_ERR_BUF_NONE_AVAIL</code>	Buffer not available.
<code>FS_ERR_DEV</code>	Device access error.

RETURNED VALUE

None.

NOTES/WARNINGS

- If `name_full_old` and `name_full_new` specify entries on different volumes, then `name_full_old` MUST specify a file. If `name_full_old` specifies a directory, an error will be returned.
- If `name_full_old` and `name_full_new` specify the same entry, the volume will not be modified and no error will be returned.
- If `name_full_old` specifies a file:
 - `name_full_new` must NOT specify a directory;
 - if `excl` is `DEF_NO` and `name_full_new` is a file, it will be removed.
- If `name_full_old` specifies a directory:
 - `name_full_new` must NOT specify a file
 - if `excl` is `DEF_NO` and `name_full_new` is a directory, `name_full_new` MUST be empty; if so, it will be removed.
- If `excl` is `DEF_NO`, `name_full_new` must not exist.
- The root directory may NOT be renamed.

A-5-7 FSEntry_TimeSet()

```
void FSEntry_TimeSet (CPU_CHAR      *name_full,
                     FS_DATE_TIME *p_time,
                     CPU_INT08U    flag,
                     FS_ERR        *p_err);
```

File	Called from	Code enabled by
fs_entry.c	Application	not FS_CFG_RD_ONLY_EN

Set a file or directory's date/time.

ARGUMENTS

name_full Name of the entry. See section 4-3 "µC/FS File and Directory Names and Paths" on page 62.

p_time Pointer to date/time.

flag Flag to indicate which Date/Time should be set

FS_DATE_TIME_CREATE	Entry Created Date/Time will be set.
FS_DATE_TIME_MODIFY	Entry Modified Date/Time will be set.
FS_DATE_TIME_ACCESS	Entry Accessed Date will be set.
FS_DATE_TIME_ALL	All the above will be set.

p_err Pointer to variable that will the receive return error code from this function:

FS_ERR_NONE	Entry date/time set successfully.
FS_ERR_NAME_NULL	Argument name_full or p_time passed a NULL pointer.
FS_ERR_FILE_INVALID_DATE_TIME	Date/time specified invalid.
FS_ERR_NAME_INVALID	Entry name specified invalid OR volume could not be found.
FS_ERR_NAME_PATH_TOO_LONG	Entry name specified too long.
FS_ERR_VOL_NOT_OPEN	Volume was not open.
FS_ERR_VOL_NOT_MOUNTED	Volume was not mounted.
FS_ERR_BUF_NONE_AVAIL	Buffer not available.
FS_ERR_DEV	Device access error.

RETURNED VALUE

None.

NOTES/WARNINGS

None.

A-6 FILE FUNCTIONS

```
void
FSfile_BufAssign (FS_FILE      *p_file,
                 void          *p_buf,
                 FS_FLAGS     mode,
                 CPU_SIZE_T    size,
                 FS_ERR        *p_err);
```

```
void
FSfile_BufFlush (FS_FILE      *p_file,
                FS_ERR        *p_err);
```

```
void
FSfile_Close    (FS_FILE      *p_file,
                FS_ERR        *p_err);
```

```
void
FSfile_ClrErr   (FS_FILE      *p_file,
                FS_ERR        *p_err);
```

```
CPU_BOOLEAN
FSfile_IsEOF    (FS_FILE      *p_file,
                FS_ERR        *p_err);
```

```
CPU_BOOLEAN
FSfile_IsErr    (FS_FILE      *p_file,
                FS_ERR        *p_err);
```

```
CPU_BOOLEAN
FSfile_IsOpen   (CPU_CHAR     *name_full,
                FS_FLAGS     *p_mode,
                FS_ERR        *p_err);
```

```
void
FSfile_LockAccept(FS_FILE      *p_file,
                 FS_ERR        *p_err);
```

```
void
FSfile_LockGet  (FS_FILE      *p_file,
                 FS_ERR        *p_err);
```

void		
FSfile_LockSet	(FS_FILE FS_ERR	*p_file, *p_err);
FS_FILE *		
FSfile_Open	(CPU_CHAR FS_FLAGS FS_ERR	*name_full, mode *p_err);
FS_FILE_SIZE		
FSfile_PosGet	(FS_FILE FS_ERR	*p_file, *p_err);
void		
FSfile_PosSet	(FS_FILE FS_FILE_OFFSET FS_FLAGS FS_ERR	*p_file, offset, origin, *p_err);
void		
FSfile_Query	(FS_FILE FS_ENTRY_INFO FS_ERR	*p_file, *p_info, *p_err);
CPU_SIZE_T		
FSfile_Rd	(FS_FILE void CPU_SIZE_T FS_ERR	*p_file, *p_dest, size, *p_err);
void		
FSfile_Truncate	(FS_FILE FS_FILE_SIZE FS_ERR	*p_file, size, *p_err);
CPU_SIZE_T		
FSfile_Wr	(FS_FILE void CPU_SIZE_T FS_ERR	*p_file, *p_src, size, *p_err);

A-6-1 FSFile_BufAssign()

```
void FSFile_BufAssign (FS_FILE      *p_file,  
                      void          *p_buf,  
                      FS_FLAGS      mode,  
                      CPU_SIZE_T    size,  
                      FS_ERR        *p_err);
```

File	Called from	Code enabled by
fs_file.c	Application; fs_setbuf(); fs_setvbuf()	FS_CFG_FILE_BUF_EN

Assign buffer to a file.

See `fs_setvbuf()` for more information.

ARGUMENTS

p_file Pointer to a file.

p_buf Pointer to buffer.

mode Buffer mode:

`FS_FILE_BUF_MODE_RD` Data buffered for reads.

`FS_FILE_BUF_MODE_WR` Data buffered for writes.

`FS_FILE_BUF_MODE_RD_WR` Data buffered for reads and writes.

`FS_FILE_BUF_MODE_SEC_ALIGNED` Force buffers to be aligned on sector boundaries.

size Size of buffer, in octets.

p_err Pointer to variable that will receive the return error code from this function:

<code>FS_ERR_NONE</code>	File buffer assigned.
<code>FS_ERR_NULL_PTR</code>	Argument <code>p_file</code> or <code>p_buf</code> passed a NULL pointer.
<code>FS_ERR_INVALID_TYPE</code>	Argument <code>p_file</code> 's type is invalid or unknown.
<code>FS_ERR_FILE_INVALID_BUF_MODE</code>	Invalid buffer mode.
<code>FS_ERR_FILE_INVALID_BUF_SIZE</code>	Invalid buffer size.
<code>FS_ERR_FILE_BUF_ALREADY_ASSIGNED</code>	Buffer already assigned.
<code>FS_ERR_FILE_NOT_OPEN</code>	File NOT open.

RETURNED VALUE

None.

NOTES/WARNINGS

None.

A-6-2 FSFile_BufFlush()

```
void FSFile_BufFlush (FS_FILE *p_file,  
                     FS_ERR *p_err);
```

File	Called from	Code enabled by
fs_file.c	Application; fs_fflush()	FS_CFG_FILE_BUF_EN

Flush buffer contents to file.

See `fs_fflush()` for more information.

ARGUMENTS

p_file Pointer to a file.

p_err Pointer to variable that will receive the return error code from this function:

<code>FS_ERR_NONE</code>	File buffer flushed successfully.
<code>FS_ERR_NULL_PTR</code>	Argument <code>p_file</code> passed a NULL pointer.
<code>FS_ERR_INVALID_TYPE</code>	Argument <code>p_file</code> 's type is invalid or unknown.
<code>FS_ERR_FILE_NOT_OPEN</code>	File NOT open.

RETURNED VALUE

None.

NOTES/WARNINGS

None.

A-6-3 FSFile_Close()

```
void FSFile_Close (FS_FILE *p_file,
                  FS_ERR *p_err);
```

File	Called from	Code enabled by
fs_file.c	Application; fs_fclose()	N/A

Close and free a file.

See `fs_fclose()` for more information.

ARGUMENTS

p_file Pointer to a file.

p_err Pointer to variable that will receive return error code from this function:

<code>FS_ERR_NONE</code>	File closed.
<code>FS_ERR_NULL_PTR</code>	Argument <code>p_file</code> passed a NULL pointer.
<code>FS_ERR_INVALID_TYPE</code>	Argument <code>p_file</code> 's type is invalid or unknown.
<code>FS_ERR_FILE_NOT_OPEN</code>	File NOT open.

RETURNED VALUE

None.

NOTES/WARNINGS

None.

A-6-4 FSFile_ClrErr()

```
void FSFile_ClrErr (FS_FILE *p_file,  
                   FS_ERR *p_err);
```

File	Called from	Code enabled by
fs_file.c	Application; fs_clearerr()	N/A

Clear EOF and error indicators on a file.

See `fs_clearerr()` for more information

ARGUMENTS

p_file Pointer to a file.

p_err Pointer to variable that will receive the return error code from this function:

<code>FS_ERR_NONE</code>	Error and end-of-file indicators cleared.
<code>FS_ERR_NULL_PTR</code>	Argument <code>p_file</code> passed a NULL pointer.
<code>FS_ERR_INVALID_TYPE</code>	Argument <code>p_file</code> 's type is invalid or unknown.
<code>FS_ERR_FILE_NOT_OPEN</code>	File NOT open.

RETURNED VALUE

None.

NOTES/WARNINGS

None.

A-6-5 FSFile_IsEOF()

```
CPU_BOOLEAN FSFile_IsEOF (FS_FILE *p_file,
                          FS_ERR *p_err);
```

File	Called from	Code enabled by
fs_file.c	Application; fs_feof()	N/A

Test EOF indicator on a file.

See `fs_feof()` for more information.

ARGUMENTS

p_file Pointer to a file.

p_err Pointer to variable that will receive the return error code from this function:

<code>FS_ERR_NONE</code>	EOF indicator obtained.
<code>FS_ERR_NULL_PTR</code>	Argument <code>p_file</code> passed a NULL pointer.
<code>FS_ERR_INVALID_TYPE</code>	Argument <code>p_file</code> 's type is invalid or unknown.
<code>FS_ERR_FILE_NOT_OPEN</code>	File NOT open.

RETURNED VALUE

`DEF_NO` if EOF indicator is NOT set or if an error occurred

`DEF_YES` if EOF indicator is set.

NOTES/WARNINGS

None.

A-6-6 FSFile_IsErr()

```
CPU_BOOLEAN FSFile_IsErr (FS_FILE *p_file,  
                          FS_ERR  *p_err);
```

File	Called from	Code enabled by
fs_file.c	Application; fs_ferr()	N/A

Test error indicator on a file.

See `fs_ferror()` for more information.

ARGUMENTS

`p_file` Pointer to a file.

`p_err` Pointer to variable that will receive the return error code from this function:

<code>FS_ERR_NONE</code>	Error indicator obtained.
<code>FS_ERR_NULL_PTR</code>	Argument <code>p_file</code> passed a NULL pointer.
<code>FS_ERR_INVALID_TYPE</code>	Argument <code>p_file</code> 's type is invalid or unknown.
<code>FS_ERR_FILE_NOT_OPEN</code>	File NOT open.

RETURNED VALUE

`DEF_NO` if error indicator is NOT set or if an error occurred

`DEF_YES` if error indicator is set.

NOTES/WARNINGS

None.

A-6-7 FSFile_IsOpen()

```
CPU_BOOLEAN FSFile_IsOpen (CPU_CHAR *name_full,
                           FS_FLAGS *p_mode
                           FS_ERR *p_err);
```

File	Called from	Code enabled by
fs_file.c	Application; FSFile_Open()	N/A

Test if file is already open.

ARGUMENTS

name_full Name of the file. See section 4-3 “ μ C/FS File and Directory Names and Paths” on page 62 for information about file names.

p_mode Pointer to variable that will receive the file access mode (see section 6-1-1 “Opening Files” on page 85 for the description the file access mode).

p_err Pointer to variable that will receive the return error code from this function:

FS_ERR_NONE	Error indicator obtained.
FS_ERR_NULL_PTR	Argument p_file passed a NULL pointer.
FS_ERR_BUF_NONE_AVAIL	No buffer available.
FS_ERR_ENTRY_NOT_FILE	Entry NOT a file.
FS_ERR_NAME_INVALID	Invalid file name or path.
FS_ERR_VOL_INVALID_SEC_NBR	Invalid sector number found in directory entry.

RETURNED VALUE

DEF_NO if file is NOT open

DEF_YES if file is open.

NOTES/WARNINGS

None.

A-6-8 FSFile_LockAccept()

```
void FSFile_LockAccept (FS_FILE *p_file,  
                        FS_ERR *p_err);
```

File	Called from	Code enabled by
fs_file.c	Application; fs_ftrylockfile()	FS_CFG_FILE_LOCK_EN

Acquire task ownership of a file (if available).

See `fs_flockfile()` for more information.

ARGUMENTS

p_file Pointer to a file.

p_err Pointer to variable that will receive return error code from this function:

<code>FS_ERR_NONE</code>	File lock acquired.
<code>FS_ERR_NULL_PTR</code>	Argument <code>p_file</code> passed a NULL pointer.
<code>FS_ERR_INVALID_TYPE</code>	Argument <code>p_file</code> 's type is invalid or unknown.
<code>FS_ERR_FILE_NOT_OPEN</code>	File NOT open.
<code>FS_ERR_FILE_LOCKED</code>	File owned by another task.

RETURNED VALUE

None.

NOTES/WARNINGS

None.

A-6-9 FSFile_LockGet()

```
void FSFile_LockGet (FS_FILE *p_file,
                    FS_ERR *p_err);
```

File	Called from	Code enabled by
fs_file.c	Application; fs_flockfile()	FS_CFG_FILE_LOCK_EN

Acquire task ownership of a file.

See `fs_flockfile()` for more information.

ARGUMENTS

p_file Pointer to a file.

p_err Pointer to variable that will the receive return error code from this function:

<code>FS_ERR_NONE</code>	File lock acquired.
<code>FS_ERR_NULL_PTR</code>	Argument <code>p_file</code> passed a NULL pointer.
<code>FS_ERR_INVALID_TYPE</code>	Argument <code>p_file</code> 's type is invalid or unknown.
<code>FS_ERR_FILE_NOT_OPEN</code>	File NOT open.

RETURNED VALUE

None.

NOTES/WARNINGS

None.

A-6-10 FSFile_LockSet()

```
void FSFile_LockSet (FS_FILE *p_file,  
                    FS_ERR *p_err);
```

File	Called from	Code enabled by
fs_file.c	Application; fs_funlockfile()	FS_CFG_FILE_LOCK_EN

Release task ownership of a file.

See `fs_funlockfile()` for more information.

ARGUMENTS

p_file Pointer to a file.

p_err Pointer to variable that will receive return error code from this function:

<code>FS_ERR_NONE</code>	File lock acquired.
<code>FS_ERR_NULL_PTR</code>	Argument <code>p_file</code> passed a NULL pointer.
<code>FS_ERR_INVALID_TYPE</code>	Argument <code>p_file</code> 's type is invalid or unknown.
<code>FS_ERR_FILE_NOT_OPEN</code>	File NOT open.
<code>FS_ERR_FILE_NOT_LOCKED</code>	File NOT locked or locked by different task.

RETURNED VALUE

None.

NOTES/WARNINGS

None.

A-6-11 FSFile_Open()

```
FS_FILE *FSFile_Open (CPU_CHAR *name_full,
                     FS_FLAGS mode
                     FS_ERR *p_err);
```

File	Called from	Code enabled by
fs_file.c	Application; fs_fopen()	N/A

Open a file.

See `fs_fopen()` for more information.

ARGUMENTS

name_full Name of the file. See section 4-3 “ μ C/FS File and Directory Names and Paths” on page 62 for information about file names.

mode File access mode (see Notes #1 and #2).

p_err Pointer to variable that will the receive return error code from this function:

<code>FS_ERR_NONE</code>	File opened.
<code>FS_ERR_NAME_NULL</code>	Argument <code>name_full</code> passed a NULL pointer.
Or entry error (see Section B.04).	

RETURNED VALUE

None.

NOTES/WARNINGS

- The access mode should be the logical OR of one or more flags :

<code>FS_FILE_ACCESS_MODE_RD</code>	File opened for reads.
<code>FS_FILE_ACCESS_MODE_WR</code>	File opened for writes.
<code>FS_FILE_ACCESS_MODE_CREATE</code>	File will be created, if necessary.
<code>FS_FILE_ACCESS_MODE_TRUNC</code>	File length will be truncated to 0.

FS_FILE_ACCESS_MODE_APPEND All writes will be performed at EOF.
FS_FILE_ACCESS_MODE_EXCL File will be opened if and only if it does not already exist.
FS_FILE_ACCESS_MODE_CACHED File data will be cached.

- If **FS_FILE_ACCESS_MODE_TRUNC** is set, then **FS_FILE_ACCESS_MODE_WR** must also be set.
- If **FS_FILE_ACCESS_MODE_EXCL** is set, then **FS_FILE_ACCESS_MODE_CREATE** must also be set.
- **FS_FILE_ACCESS_MODE_RD** and/or **FS_FILE_ACCESS_MODE_WR** must be set.
- The mode string argument of **fs_fopen()** function can specify a subset of the possible valid modes for this function. The equivalent modes of **fs_fopen()** mode strings are shown in Table 5-4.

fopen() Mode String	mode Equivalent
"r" or "rb"	FS_FILE_ACCESS_MODE_RD
"w" or "wb"	FS_FILE_ACCESS_MODE_WR FS_FILE_ACCESS_MODE_CREATE FS_FILE_ACCESS_MODE_TRUNC
"a" or "ab"	FS_FILE_ACCESS_MODE_WR FS_FILE_ACCESS_MODE_CREATE FS_FILE_ACCESS_MODE_APPEND
"r+" or "rb+" or "r+b"	FS_FILE_ACCESS_MODE_RD FS_FILE_ACCESS_MODE_WR
"w+" or "wb+" or "w+b"	FS_FILE_ACCESS_MODE_RD FS_FILE_ACCESS_MODE_WR FS_FILE_ACCESS_MODE_CREATE FS_FILE_ACCESS_MODE_TRUNC
"a+" or "ab+" or "a+b"	FS_FILE_ACCESS_MODE_RD FS_FILE_ACCESS_MODE_WR FS_FILE_ACCESS_MODE_CREATE FS_FILE_ACCESS_MODE_APPEND

Table A-1 **fs_fopen()** mode strings and mode equivalents.

A-6-12 FSFile_PosGet()

```
FS_FILE_SIZE FSFile_PosGet (FS_FILE *p_file,
                             FS_ERR *p_err);
```

File	Called from	Code enabled by
fs_file.c	Application; fs_ftell(); fs_fgetpos()	N/A

Set file position indicator.

See `fs_ftell()` for more information.

ARGUMENTS

`p_file` Pointer to a file.

`p_err` Pointer to variable that will receive return error code from the function:

<code>FS_ERR_NONE</code>	File position gotten successfully.
<code>FS_ERR_NULL_PTR</code>	Argument <code>p_file</code> passed a NULL pointer.
<code>FS_ERR_INVALID_TYPE</code>	Argument <code>p_file</code> 's type is invalid or unknown.
<code>FS_ERR_FILE_NOT_OPEN</code>	File NOT open.
<code>FS_ERR_FILE_INVALID_POS</code>	Invalid file position.

RETURNED VALUE

The current file position, if no errors (see Note).

0, otherwise.

NOTES/WARNINGS

The file position returned is the number of bytes from the beginning of the file up to the current file position.

A-6-13 FSFile_PosSet()

```
void FSFile_PosSet (FS_FILE      *p_file,  
                   FS_FILE_OFFSET offset,  
                   FS_FLAGS      origin,  
                   FS_ERR        *p_err);
```

File	Called from	Code enabled by
fs_file.c	Application; fs_fseek(); fs_fsetpos()	N/A

Get file position indicator.

See `fs_fseek()` for more information.

ARGUMENTS

p_file Pointer to a file.

offset Offset from the file position specified by origin.

origin Reference position for offset:

<code>FS_FILE_ORIGIN_START</code>	Offset is from the beginning of the file.
<code>FS_FILE_ORIGIN_CUR</code>	Offset is from the current file position.
<code>FS_FILE_ORIGIN_END</code>	Offset is from the end of the file.

p_err Pointer to variable that will receive return error code from the function:

<code>FS_ERR_NONE</code>	File position set successfully.
<code>FS_ERR_NULL_PTR</code>	Argument <code>p_file</code> passed a NULL pointer.
<code>FS_ERR_INVALID_TYPE</code>	Argument <code>p_file</code> 's type is invalid or unknown.
<code>FS_ERR_FILE_INVALID_ORIGIN</code>	Invalid origin specified.
<code>FS_ERR_FILE_INVALID_OFFSET</code>	Invalid offset specified.
<code>FS_ERR_FILE_NOT_OPEN</code>	File NOT open.

RETURNED VALUE

None.

NOTES/WARNINGS

None.

A-6-14 FSFile_Query()

```
void FSFile_Query (FS_FILE      *p_file,  
                  FS_ENTRY_INFO *p_info,  
                  FS_ERR       *p_err);
```

File	Called from	Code enabled by
fs_file.c	Application; fs_fstat()	N/A

FSFile_Query() is used to get information about a file.

ARGUMENTS

p_file Pointer to a file.

p_info Pointer to structure that will receive the file information (see Note).

p_err Pointer to variable that will the receive return error code from the function:

FS_ERR_NONE	File information obtained successfully.
FS_ERR_NULL_PTR	Argument p_file or p_info passed a NULL pointer.
FS_ERR_INVALID_TYPE	Argument p_file 's type is invalid or unknown.
FS_ERR_FILE_NOT_OPEN	File NOT open.

RETURNED VALUE

None.

NOTES/WARNINGS

None.

A-6-15 FSFile_Rd()

```
CPU_SIZE_T  FSFile_Rd (FS_FILE    *p_file,
                      void        *p_dest,
                      CPU_SIZE_T  size,
                      FS_ERR      *p_err);
```

File	Called from	Code enabled by
fs_file.c	Application; fs_fread()	N/A

Read from a file.

See `fs_fread()` for more information.

ARGUMENTS

p_file Pointer to a file.

p_dest Pointer to destination buffer.

size

Number of octets to read.

p_err Pointer to variable that will the receive return error code from the function:

<code>FS_ERR_NONE</code>	File read successfully.
<code>FS_ERR_EOF</code>	End-of-file reached.
<code>FS_ERR_NULL_PTR</code>	Argument <code>p_file/p_dest</code> passed a NULL pointer.
<code>FS_ERR_INVALID_TYPE</code>	Argument <code>p_file</code> 's type is invalid or unknown.
<code>FS_ERR_FILE_NOT_OPEN</code>	File NOT open.
<code>FS_ERR_FILE_INVALID_OP</code>	Invalid operation on file.
<code>FS_ERR_DEV</code>	Device access error.

RETURNED VALUE

The number of bytes read, if file read successful.

0, otherwise.

NOTES/WARNINGS

None.

A-6-16 FSFile_Truncate()

```
void FSFile_Truncate (FS_FILE      *p_file,
                     FS_FILE_SIZE  size,
                     FS_ERR        *p_err);
```

File	Called from	Code enabled by
fs_file.c	Application; fs_ftruncate()	not FS_CFG_RD_ONLY_EN

Truncate a file.

See `fs_ftruncate()` for more information.

ARGUMENTS

p_file Pointer to a file.

size Size of the file after truncation

p_err Pointer to variable that will receive return error code from the function:

FS_ERR_NONE	File truncated successfully.
FS_ERR_NULL_PTR	Argument <code>p_file</code> passed a NULL pointer.
FS_ERR_INVALID_TYPE	Argument <code>p_file</code> 's type is invalid or unknown.
FS_ERR_FILE_NOT_OPEN	File NOT open.

RETURNED VALUE

None.

NOTES/WARNINGS

None.

A-6-17 FSFile_Wr()

```
CPU_SIZE_T  FSFile_Wr (FS_FILE    *p_file,  
                      void        *p_src,  
                      CPU_SIZE_T  size,  
                      FS_ERR      *p_err);
```

File	Called from	Code enabled by
fs_file.c	Application; fs_fwrite()	not FS_CFG_RD_ONLY_EN

Write to a file.

See `fs_fwrite()` for more information.

ARGUMENTS

p_file Pointer to a file.

p_src Pointer to source buffer.

size Number of octets to write.

p_err Pointer to variable that will receive return error code from the function:

FS_ERR_NONE	File write successfully.
FS_ERR_NULL_PTR	Argument <code>p_file/p_src</code> passed a NULL pointer.
FS_ERR_INVALID_TYPE	Argument <code>p_file</code> 's type is invalid or unknown.
FS_ERR_FILE_NOT_OPEN	File NOT open.
FS_ERR_FILE_INVALID_OP	Invalid operation on file.
FS_ERR_DEV	Device access error.

RETURNED VALUE

The number of bytes written, if file write successful.

0, otherwise.

NOTES/WARNINGS

None.

A-7 VOLUME FUNCTIONS

void		
FSVol_Close	(CPU_CHAR FS_ERR	*name_vol, *p_err);
void		
FSVol_Fmt	(CPU_CHAR void FS_ERR	*name_vol, *p_fs_cfg, *p_err);
void		
FSVol_GetDfltVolName	(CPU_CHAR	*name_vol);
FS_QTY		
FSVol_GetVolCnt	(void);	
FS_QTY		
FSVol_GetVolCntMax	(void);	
void		
FSVol_GetVolName	(FS_QTY CPU_CHAR	vol_nbr, *name_vol);
CPU_BOOLEAN		
FSVol_IsMounted	(CPU_CHAR	*name_vol);
void		
FSVol_LabelGet	(CPU_CHAR CPU_CHAR CPU_SIZE_T FS_ERR	*name_vol, *label, len_max, *p_err);
void		
FSVol_LabelSet	(CPU_CHAR CPU_CHAR FS_ERR	*name_vol, *label, *p_err);
void		
FSVol_Open	(CPU_CHAR CPU_CHAR FS_PARTITION_NBR FS_ERR	*name_vol, *name_dev, partition_nbr, *p_err);

```
void
FSVol_Query      (CPU_CHAR      *name_vol,
                  FS_VOL_INFO   *p_info,
                  FS_ERR        *p_err);
```

```
void
FSVol_Rd         (CPU_CHAR      *name_vol,
                  void          *p_dest,
                  FS_SEC_NBR    start,
                  FS_SEC_QTY    cnt,
                  FS_ERR        *p_err);
```

```
void
FSVol_Wr         (CPU_CHAR      *name_vol,
                  void          *p_src,
                  FS_SEC_NBR    start,
                  FS_SEC_QTY    cnt,
                  FS_ERR        *p_err);
```

A-7-1 FSVol_Close()

```
void FSVol_Close (CPU_CHAR *name_vol,  
                 FS_ERR *p_err);
```

File	Called from	Code enabled by
fs_vol.c	Application	N/A

Close and free a volume.

ARGUMENTS

name_vol Volume name.

p_err Pointer to variable that will receive the return error code from this function.
See Note #2.

FS_ERR_NONE Volume opened.

FS_ERR_NAME_NULL Argument **name_vol** passed a NULL pointer.

FS_ERR_VOL_NOT_OPEN Volume not open.

RETURNED VALUE

None.

NOTES/WARNINGS

None.

A-7-2 FSVol_Fmt()

```
void FSVol_Fmt (CPU_CHAR *name_vol,
               void *p_fs_cfg,
               FS_ERR *p_err);
```

File	Called from	Code enabled by
fs_vol.c	Application	not FS_CFG_RD_ONLY_EN

Format a volume.

ARGUMENTS

name_vol Colume name.

p_fs_cfg Pointer to file system driver-specific configuration. For all file system drivers, if this is a pointer to NULL, then the default configuration will be selected. More information about the appropriate structure for the FAT file system driver can be found in Chapter 6.

p_err Pointer to variable that will receive the return error code from this function

FS_ERR_NONE	Volume formatted.
FS_ERR_DEV	Device error.
FS_ERR_DEV_INVALID_SIZE	Invalid device size.
FS_ERR_NAME_NULL	Argument name_vol passed a NULL pointer.
FS_ERR_VOL_DIRS_OPEN	Directories open on volume.
FS_ERR_VOL_FILES_OPEN	Files open on volume.
FS_ERR_VOL_INVALID_SYS	Invalid file system parameters.
FS_ERR_VOL_NOT_OPEN	Volume not open.

REQUIRED CONFIGURATION

None.

NOTES/WARNINGS

- Function blocked if files or directories are open on the volume. All files and directories *must* be closed prior to formatting the volume.
- For any file system driver, if `p_fs_cfg` is a pointer to NULL, then the default configuration will be selected. If non-NULL, the argument should be passed a pointer to the appropriate configuration structure. For the FAT file system driver, `p_fs_cfg` should be passed a pointer to a `FS_FAT_SYS_CFG`.

A-7-3 FSVol_GetDfltVolName()

```
void FSVol_GetDfltVolName (CPU_CHAR *name_vol);
```

File	Called from	Code enabled by
fs_vol.c	Application	N/A

Get name of the default volume.

ARGUMENTS

name_vol String buffer that will receive the volume name (see Note #2).

RETURNED VALUE

None.

NOTES/WARNINGS

- **name_vol** MUST point to a character array of **FS_CFG_MAX_VOL_NAME_LEN** characters.
- If the volume does not exist, **name_vol** will receive an empty string.

A-7-4 FSVol_GetVolCnt()

FS_QTY FSVol_GetVolCnt (void);

File	Called from	Code enabled by
fs_vol.c	Application	N/A

Get the number of open volumes.

ARGUMENTS

None.

RETURNED VALUE

Number of volumes currently open.

NOTES/WARNINGS

None.

A-7-5 FSVol_GetVolCntMax()

FS_QTY FSVol_GetVolCntMax (void);

File	Called from	Code enabled by
fs_vol.c	Application	N/A

Get the maximum possible number of open volumes.

ARGUMENTS

None.

RETURNED VALUE

The maximum number of open volumes.

NOTES/WARNINGS

None.

A-7-6 FSVol_GetVolName()

```
void FSVol_GetVolName (FS_QTY    vol_nbr,  
                      CPU_CHAR  *name_vol);
```

File	Called from	Code enabled by
fs_vol.c	Application	N/A

Get name of the nth open volume. `vol_nbr` should be between 0 and the return value of `FSVol_GetNbrVols()` (inclusive).

ARGUMENTS

`vol_nbr` Volume number.

`name_vol` String buffer that will receive the volume name (see Note #2).

RETURNED VALUE

None.

NOTES/WARNINGS

- `name_vol` MUST point to a character array of `FS_CFG_MAX_VOL_NAME_LEN` characters.
- If the volume does not exist, `name_vol` will receive an empty string.

A-7-7 FSVol_IsDflt()

```
CPU_BOOLEAN FSVol_IsDflt (CPU_CHAR *name_vol);
```

File	Called from	Code enabled by
fs_vol.c	Application	N/A

Determine whether a volume is the default volume.

ARGUMENTS

`name_vol` Volume name.

RETURNED VALUE

`DEF_YES`, if the volume with name `name_vol` is the default volume.

`DEF_NO`, if no volume with name `name_vol` exists.

`DEF_NO`, or the volume with name `name_vol` is not the default volume.

NOTES/WARNINGS

None.

A-7-8 FSVol_IsMounted()

```
CPU_BOOLEAN FSVol_IsMounted (CPU_CHAR *name_vol);
```

File	Called from	Code enabled by
fs_vol.c	Application	N/A

Determine whether a volume is mounted.

ARGUMENTS

`name_vol` Volume name.

RETURNED VALUE

`DEF_YES`, if the volume is open and is mounted.

`DEF_NO`, if the volume is not open or is not mounted.

NOTES/WARNINGS

None.

A-7-9 FSVol_LabelGet()

```
void FSVol_LabelGet (CPU_CHAR   *name_vol,
                    CPU_CHAR   *label,
                    CPU_SIZE_T  len_max,
                    FS_ERR      *p_err);
```

File	Called from	Code enabled by
fs_vol.c	Application	N/A

Get volume label.

ARGUMENTS

name_vol Volume name.

label String buffer that will receive volume label.

len_max Size of string buffer.

p_err Pointer to variable that will receive the return error code from this function:

FS_ERR_NONE	Label gotten.
FS_ERR_DEV_CHNGD	Device has changed.
FS_ERR_NAME_NULL	Argument name_vol passed a NULL pointer.
FS_ERR_NULL_PTR	Argument label passed a NULL pointer.
FS_ERR_DEV	Device access error.
FS_ERR_VOL_LABEL_NOT_FOUND	Volume label was not found.
FS_ERR_VOL_LABEL_TOO_LONG	Volume label is too long.
FS_ERR_VOL_NOT_MOUNTED	Volume is not mounted.
FS_ERR_VOL_NOT_OPEN	Volume is not open.

REQUIRED CONFIGURATION

None.

NOTES/WARNINGS

`len_max` is the maximum length string that can be stored in the buffer label; it does NOT include the final NULL character. The buffer label MUST be of at least `len_max + 1` characters.

A-7-10 FSVol_LabelSet()

```
void FSVol_LabelSet (CPU_CHAR *name_vol,
                    CPU_CHAR *label,
                    FS_ERR *p_err);
```

File	Called from	Code enabled by
fs_vol.c	Application	not FS_CFG_RD_ONLY_EN

Set volume label.

ARGUMENTS

name_vol Volume name.

label Volume label.

p_err Pointer to variable that will receive the return error code from this function:

FS_ERR_NONE	Label set.
FS_ERR_DEV_CHNGD	Device has changed.
FS_ERR_NAME_NULL	Argument name_vol passed a NULL pointer.
FS_ERR_NULL_PTR	Argument label passed a NULL pointer.
FS_ERR_DEV	Device access error.
FS_ERR_DIR_FULL	Directory is full (space could not be allocated).
FS_ERR_DEV_FULL	Device is full (space could not be allocated).
FS_ERR_VOL_LABEL_INVALID	Volume label is invalid.
FS_ERR_VOL_LABEL_TOO_LONG	Volume label is too long.
FS_ERR_VOL_NOT_MOUNTED	Volume is not mounted.
FS_ERR_VOL_NOT_OPEN	Volume is not open.

RETURNED VALUE

None.

NOTES/WARNINGS

The label on a FAT volume must be no longer than 11-characters, each belonging to the set of valid short file name (SFN) characters. Before it is committed to the volume, the label will be converted to upper case and will be padded with spaces until it is an 11-character string.

A-7-11 FSVol_Open()

```
void FSVol_Open (CPU_CHAR      *name_vol,
                 CPU_CHAR      *name_dev,
                 FS_PARTITION_NBR partition_nbr,
                 FS_ERR         *p_err);
```

File	Called from	Code enabled by
fs_vol.c	Application	N/A

Open a volume.

ARGUMENTS

name_vol Volume name. See Section 2.04 for information about device names.

name_dev Device name.

partition_nbr Partition number. If 0, the default partition will be mounted.

p_err Pointer to variable that will receive the return error code from this function. See Note #2.

FS_ERR_NONE	Volume opened.
FS_ERR_DEV_VOL_OPEN	Volume open on device.
FS_ERR_INVALID_SIG	Invalid MBR signature.
FS_ERR_NAME_NULL	Argument name_vol / name_dev passed a NULL pointer.
FS_ERR_PARTITION_INVALID_NBR	Invalid partition number.
FS_ERR_PARTITION_NOT_FOUND	Partition not found.
FS_ERR_VOL_ALREADY_OPEN	Volume is already open.
FS_ERR_VOL_INVALID_NAME	Volume name invalid.
FS_ERR_VOL_NONE_AVAIL	No volumes available.

Or device access error (see section B-4 “Device Error Codes” on page 394).

RETURNED VALUE

None.

NOTES/WARNINGS

- If `FS_ERR_PARTITION_NOT_FOUND` is returned, then no valid partition (or valid file system) was found on the device. It is still placed on the list of used volumes; however, it cannot be addressed as a mounted volume (e.g., files cannot be accessed). Thereafter, unless a new device is inserted, the only valid commands are
 - `FSVol_Fmt()`, which creates a file system on the device;
 - `FSVol_Close()`, which frees the volume structure;
 - `FSVol_Query()`, which returns information about the device.
- If `FS_ERR_DEV`, `FS_ERR_DEV_NOT_PRESENT`, `FS_ERR_DEV_IO` or `FS_ERR_DEV_TIMEOUT` is returned, then the volume has been added to the file system, though the underlying device is probably not present. The volume will need to be either closed and re-added, or refreshed.

A-7-12 FSVol_Query()

```
void FSVol_Query (CPU_CHAR      *name_vol,
                  FS_VOL_INFO  *p_info,
                  FS_ERR       *p_err);
```

File	Called from	Code enabled by
fs_vol.c	Application	N/A

Obtain information about a volume.

ARGUMENTS

name_vol Volume name.

p_info Pointer to structure that will receive volume information (see Note).

p_err Pointer to variable that will receive the return error code from this function:

FS_ERR_NONE	Volume information obtained.
FS_ERR_DEV	Device access error.
FS_ERR_NAME_NULL	Argument name_vol passed a NULL pointer.
FS_ERR_NULL_PTR	Argument p_info passed a NULL pointer.
FS_ERR_VOL_NOT_OPEN	Volume is not open.

RETURNED VALUE

None.

NOTES/WARNINGS

None.

A-7-13 FSVol_Rd()

```
void FSVol_Rd (CPU_CHAR   *name_vol,  
              void       *p_dest,  
              FS_SEC_NBR  start,  
              FS_SEC_QTY  cnt,  
              FS_ERR      *p_err);
```

File	Called from	Code enabled by
fs_vol.c	Application	N/A

Reads data from volume sector(s).

ARGUMENTS

name_vol Volume name.

p_dest Pointer to destination buffer.

start Start sector of read.

cnt Number of sectors to read

p_err Pointer to variable that will receive the return error code from this function

FS_ERR_NONE	Sector(s) read.
FS_ERR_DEV	Device access error.
FS_ERR_NAME_NULL	Argument name_vol passed a NULL pointer.
FS_ERR_NULL_PTR	Argument p_dest passed a NULL pointer.
FS_ERR_VOL_NOT_MOUNTED	Volume is not mounted.
FS_ERR_VOL_NOT_OPEN	Volume is not open.

RETURNED VALUE

None.

REQUIRED CONFIGURATION

None.

NOTES/WARNINGS

None.

A-7-14 FSVol_Wr()

```
void FSVol_Wr (CPU_CHAR   *name_vol,  
              void       *p_src,  
              FS_SEC_NBR  start,  
              FS_SEC_QTY  cnt,  
              FS_ERR      *p_err);
```

File	Called from	Code enabled by
fs_vol.c	Application	not FS_CFG_RD_ONLY_EN

Writes data to volume sector(s).

ARGUMENTS

name_vol Volume name.

p_src Pointer to source buffer.

start Start sector of write.

cnt Number of sectors to write

p_err Pointer to variable that will receive the return error code from this function

FS_ERR_NONE	Sector(s) written.
FS_ERR_DEV	Device access error.
FS_ERR_NAME_NULL	Argument name_vol passed a NULL pointer.
FS_ERR_NULL_PTR	Argument p_src passed a NULL pointer.
FS_ERR_VOL_NOT_MOUNTED	Volume is not mounted.
FS_ERR_VOL_NOT_OPEN	Volume is not open.

RETURNED VALUE

None.

NOTES/WARNINGS

None.

A-8 VOLUME CACHE FUNCTIONS

```
void
FSVol_CacheAssign (CPU_CHAR      *name_vol,
                  FS_VOL_CACHE_API *p_cache_api,
                  void            *p_cache_data,
                  CPU_INT32U      size,
                  CPU_INT08U      pct_mgmt,
                  CPU_INT08U      pct_dir,
                  FS_FLAGS        mode,
                  FS_ERR          *p_err);
```

```
void
FSVol_CacheInvalidate (CPU_CHAR *name_vol,
                      FS_ERR    *p_err);
```

```
void
FSVol_CacheFlush (CPU_CHAR *name_vol,
                 FS_ERR    *p_err);
```

A-8-1 FSVol_CacheAssign()

```
void FSVol_CacheAssign (CPU_CHAR          *name_vol,  
                        FS_VOL_CACHE_API *p_cache_api,  
                        void              *p_cache_data,  
                        CPU_INT32U       size,  
                        CPU_INT08U       pct_mgmt,  
                        CPU_INT08U       pct_dir,  
                        FS_FLAGS         mode,  
                        FS_ERR           *p_err)
```

File	Called from	Code enabled by
fs_vol.c	Application	FS_CFG_CACHE_EN

Assign cache to a volume.

ARGUMENTS

name_vol Volume name.

p_cache_api Pointer to: (a) cache API to use; OR (b) NULL, if default cache API should be used.

p_cache_data Pointer to cache data.

size Size, in bytes, of cache buffer.

pct_mgmt Percent of cache buffer dedicated to management sectors.

pct_dir Percent of cache buffer dedicated to directory sectors.

mode Cache mode

FS_VOL_CACHE_MODE_WR_THROUGH
FS_VOL_CACHE_MODE_WR_BACK
FS_VOL_CACHE_MODE_RD

p_err Pointer to variable that will receive return error code from this function:

<code>FS_ERR_NONE</code>	Cache created.
<code>FS_ERR_NAME_NULL</code>	'name_vol' passed a NULL pointer.
<code>FS_ERR_VOL_NOT_OPEN</code>	Volume not open.
<code>FS_ERR_NULL_PTR</code>	'p_cache_data' passed a NULL pointer.
<code>FS_ERR_CACHE_INVALID_MODE</code>	Mode specified invalid
<code>FS_ERR_CACHE_INVALID_SEC_TYPE</code>	Sector type sepecified invalid.
<code>FS_ERR_CACHE_TOO_SMALL</code>	Size specified too small for cache.

RETURNED VALUE

None.

NOTES/WARNINGS

None.

A-8-2 FSVol_CacheInvalidate ()

```
void FSVol_CacheInvalidate (CPU_CHAR *name_vol,  
                             FS_ERR *p_err)
```

File	Called from	Code enabled by
fs_vol.c	Application	FS_CFG_CACHE_EN

Invalidate cache on a volume.

ARGUMENTS

name_vol Volume name.

p_err Pointer to variable that will receive return error code from this function:

FS_ERR_NONE	Cache created.
FS_ERR_NAME_NULL	'name_vol' passed a NULL pointer.
FS_ERR_DEV_CHNGD	Device has changed.
FS_ERR_VOL_NO_CACHE	No cache assigned to volume.
FS_ERR_VOL_NOT_OPEN	Volume not open.
FS_ERR_VOL_NOT_MOUNTED	Volume not mounted.

RETURNED VALUE

None.

NOTES/WARNINGS

None.

A-8-3 FSVol_CacheFlush ()

```
void FSVol_CacheFlush (CPU_CHAR *name_vol,
                      FS_ERR *p_err)
```

File	Called from	Code enabled by
fs_vol.c	Application	FS_CFG_CACHE_EN

Flush cache on a volume.

ARGUMENTS

name_vol Volume name.

p_err Pointer to variable that will receive return error code from this function:

FS_ERR_NONE	Cache created.
FS_ERR_NAME_NULL	'name_vol' passed a NULL pointer.
FS_ERR_DEV_CHNGD	Device has changed.
FS_ERR_VOL_NO_CACHE	No cache assigned to volume.
FS_ERR_VOL_NOT_OPEN	Volume not open.
FS_ERR_VOL_NOT_MOUNTED	Volume not mounted.
FS_ERR_DEV_INVALID_SEC_NBR	Sector start or count invalid.
FS_ERR_DEV_INVALID_LOW_FMT	Device needs to be low-level formatted.
FS_ERR_DEV_IO	Device I/O error.
FS_ERR_DEV_TIMEOUT	Device timeout error.
FS_ERR_DEV_NOT_PRESENT	Device is not present.

RETURNED VALUE

None.

NOTES/WARNINGS

None.

A-9 SD/MMC DRIVER FUNCTIONS

```
void
FSDev_SD_Card_QuerySD (CPU_CHAR      *name_dev,
                       FS_DEV_SD_INFO *p_info,
                       FS_ERR         *p_err);
```

```
void
FSDev_SD_SPI_QuerySD (CPU_CHAR      *name_dev,
                      FS_DEV_SD_INFO *p_info,
                      FS_ERR         *p_err);
```

```
void
FSDev_SD_Card_RdCID (CPU_CHAR      *name_dev,
                     CPU_INT08U    *p_info,
                     FS_ERR         *p_err);
```

```
void
FSDev_SD_SPI_RdCID (CPU_CHAR      *name_dev,
                    CPU_INT08U    *p_info,
                    FS_ERR         *p_err);
```

```
void
FSDev_SD_Card_RdCSD (CPU_CHAR      *name_dev,
                     CPU_INT08U    *p_info,
                     FS_ERR         *p_err);
```

```
void
FSDev_SD_SPI_RdCSD (CPU_CHAR      *name_dev,
                    CPU_INT08U    *p_info,
                    FS_ERR         *p_err);
```

A-9-1 FSDev_SD_xxx_QuerySD()

```
void FSDev_SD_Card_QuerySD (CPU_CHAR      *name_dev,
                           FS_DEV_SD_INFO *p_info,
                           FS_ERR         *p_err);
void FSDev_SD_SPI_QuerySD (CPU_CHAR      *name_dev,
                           FS_DEV_SD_INFO *p_info,
                           FS_ERR         *p_err);
```

File	Called from	Code enabled by
fs_dev_sd_card.c, fs_dev_sd_spi.c	Application	N/A

Get low-level information about SD/MMC card.

ARGUMENTS

name_dev Device name (see Note).

p_info Pointer to structure that will receive SD/MMC card information.

p_err Pointer to variable that will receive return error code from this function:

FS_ERR_NONE	SD/MMC info obtained.
FS_ERR_NAME_NULL	Argument name_dev passed a NULL pointer.
FS_ERR_NULL_PTR	Argument p_info passed a NULL pointer.
FS_ERR_DEV_INVALID	Argument name_dev specifies an invalid device
FS_ERR_DEV_NOT_OPEN	Device is not open.
FS_ERR_DEV_NOT_PRESENT	Device is not present.
FS_ERR_DEV_IO	Device I/O error.
FS_ERR_DEV_TIMEOUT	Device timeout.

RETURNED VALUE

None.

NOTES/WARNINGS

The device *must* be a SD/MMC device; (for `FSDev_SD_Card_QuerySD()`, e.g., “`sdcard:0:`”; for `FSDev_SD_SPI_QuerySD()`, e.g., “`sd:0:`”).

A-9-2 FSDev_SD_xxx_RdCID()

```
void FSDev_SD_Card_RdCID (CPU_CHAR    *name_dev,
                        CPU_INT08U    *p_info,
                        FS_ERR         *p_err);
void FSDev_SD_SPI_RdCID (CPU_CHAR    *name_dev,
                        CPU_INT08U    *p_info,
                        FS_ERR         *p_err);
```

File	Called from	Code enabled by
fs_dev_sd_card.c, fs_dev_sd_spi.c	Application	N/A

Read SD/MMC Card ID (CID) register.

ARGUMENTS

name_dev Device name (see Note #1).

p_dest Pointer to 16-byte buffer that will receive SD/MMC Card ID register.

p_err Pointer to variable that will the receive return error code from this function:

FS_ERR_NONE	SD/MMC Card ID register read.
FS_ERR_NAME_NULL	Argument name_dev passed a NULL pointer.
FS_ERR_NULL_PTR	Argument p_dest passed a NULL pointer.
FS_ERR_DEV_INVALID	Argument name_dev specifies an invalid device
FS_ERR_DEV_NOT_OPEN	Device is not open.
FS_ERR_DEV_NOT_PRESENT	Device is not present.
FS_ERR_DEV_IO	Device I/O error.
FS_ERR_DEV_TIMEOUT	Device timeout.

RETURNED VALUE

None.

NOTES/WARNINGS

- The device *must* be a SD/MMC device; (for `FSDev_SD_Card_QuerySD()`, e.g., “sdcard:0:”; for `FSDev_SD_SPI_QuerySD()`, e.g., “sd:0:”).
- For SD cards, the structure of the CID is defined in the SD Card Association’s “Physical Layer Simplified Specification Version 2.00”, Section 5.1. For MMC cards, the structure of the CID is defined in the JEDEC’s “MultiMediaCard (MMC) Electrical Standard, High Capacity”, Section 8.2.

A-9-3 FSDev_SD_xxx_RdCSD()

```
void FSDev_SD_Card_RdCSD (CPU_CHAR    *name_dev,
                          CPU_INT08U  *p_info,
                          FS_ERR       *p_err);
void FSDev_SD_SPI_RdCSD (CPU_CHAR    *name_dev,
                          CPU_INT08U  *p_info,
                          FS_ERR       *p_err);
```

File	Called from	Code enabled by
fs_dev_sd_card.c, fs_dev_sd_spi.c	Application	N/A

Read SD/MMC Card-Specific Data (CSD) register.

ARGUMENTS

name_dev Device name (see Note #1).

p_dest Pointer to 16-byte buffer that will receive SD/MMC Card-Specific Data register.

p_err Pointer to variable that will the receive return error code from this function:

FS_ERR_NONE	SD/MMC Card-Specific Data register read.
FS_ERR_NAME_NULL	Argument name_dev passed a NULL pointer.
FS_ERR_NULL_PTR	Argument p_dest passed a NULL pointer.
FS_ERR_DEV_INVALID	Argument name_dev specifies an invalid device
FS_ERR_DEV_NOT_OPEN	Device is not open.
FS_ERR_DEV_NOT_PRESENT	Device is not present.
FS_ERR_DEV_IO	Device I/O error.
FS_ERR_DEV_TIMEOUT	Device timeout.

RETURNED VALUE

None.

NOTES/WARNINGS

- The device *must* be a SD/MMC device; (for `FSDev_SD_Card_QuerySD()`, e.g., “`sdcard:0:`”; for `FSDev_SD_SPI_QuerySD()`, e.g., “`sd:0:`”).
- For SD cards, the structure of the CSD is defined in the SD Card Association’s “Physical Layer Simplified Specification Version 2.00”, Section 5.3.2 (v1.x and v2.0 standard capacity) or Section 5.3.3. (v2.0 high capacity). For MMC cards, the structure of the CSD is defined in the JEDEC’s “MultiMediaCard (MMC) Electrical Standard, High Capacity”, Section 8.3.

A-10 NAND DRIVER FUNCTIONS

```
void  
FSDev_NAND_LowFmt      (CPU_CHAR  *name_dev,  
                        FS_ERR     *p_err);
```

```
void  
FSDev_NAND_LowMount   (CPU_CHAR  *name_dev,  
                        FS_ERR     *p_err);
```

```
void  
FSDev_NAND_LowUnmount (CPU_CHAR  *name_dev,  
                        FS_ERR     *p_err);
```

A-10-1 FSDev_NAND_LowFmt()

```
void FSDev_NAND_LowFmt (CPU_CHAR *name_dev,  
                        FS_ERR    *p_err);
```

File	Called from	Code enabled by
fs_dev_nand.c	Application	N/A

Low-level format a NAND device.

ARGUMENTS

name_dev Device name (see Note).

p_err Pointer to variable that will receive the return error code from this function:

FS_ERR_NONE	Device low-level formatted successfully.
FS_ERR_NAME_NULL	Argument name_dev passed a NULL pointer.
FS_ERR_DEV_INVALID	Argument name_dev specifies an invalid device
FS_ERR_DEV_NOT_OPEN	Device is not open.
FS_ERR_DEV_NOT_PRESENT	Device is not present.
FS_ERR_DEV_INVALID_LOW_FMT	Device needs to be low-level formatted.
FS_ERR_DEV_IO	Device I/O error.
FS_ERR_DEV_TIMEOUT	Device timeout.

RETURNED VALUE

None.

NOTES/WARNINGS

The device *must* be a NAND device (e.g., “**nand:0:**”).

A NAND medium **MUST** be low-level formatted with this driver prior to access by the high-level file system, a requirement which the device module enforces.

A-10-2 FSDev_NAND_LowMount()

```
void FSDev_NAND_LowMount (CPU_CHAR *name_dev,
                          FS_ERR *p_err);
```

File	Called from	Code enabled by
fs_dev_nand.c	Application	N/A

Low-level mount a NAND device.

ARGUMENTS

name_dev Device name (see Note).

p_err Pointer to variable that will receive the return error code from this function:

FS_ERR_NONE	Device low-level mounted successfully.
FS_ERR_NAME_NULL	Argument name_dev passed a NULL pointer.
FS_ERR_DEV_INVALID	Argument name_dev specifies an invalid device
FS_ERR_DEV_NOT_OPEN	Device is not open.
FS_ERR_DEV_NOT_PRESENT	Device is not present.
FS_ERR_CORRUPT_LOW_FMT	Device low-level format corrupted.
FS_ERR_DEV_INVALID_LOW_FMT	Device needs to be low-level formatted.
FS_ERR_DEV_INCOMPATIBLE_LOW_PARAMS	Device configuration not compatible with existing format.
S_ERR_DEV_IO	Device I/O error.
FS_ERR_DEV_TIMEOUT	Device timeout.

RETURNED VALUE

None.

NOTES/WARNINGS

The device *must* be a NAND device (e.g., “**nand:0:**”).

Low-level mounting parses the on-device structure, detecting the presence of a valid low-level format. If `FS_ERR_DEV_INVALID_LOW_FMT` is returned, the device is NOT low-level formatted.

If an existing on-device low-level format is found but doesn't match the format prompted by specified device configuration, `FS_ERR_DEV_INCOMPATIBLE_LOW_PARAMS` will be returned. A low-level format is required.

If an existing and compatible on-device low-level format is found, but is not usable because of some metadata corruption, `FS_ERR_DEV_CORRUPT_LOW_FMT` will be returned. A chip erase and/or low-level format is required.

A-10-3 FSDev_NAND_LowUnmount()

```
void FSDev_NAND_LowUnmount (CPU_CHAR *name_dev,
                            FS_ERR *p_err);
```

File	Called from	Code enabled by
fs_dev_nand.c	Application	N/A

Low-level unmount a NAND device.

ARGUMENTS

name_dev Device name (see Note).

p_err Pointer to variable that will the receive return error code from this function:

FS_ERR_NONE	Device low-level unmounted successfully.
FS_ERR_NAME_NULL	Argument name_dev passed a NULL pointer.
FS_ERR_DEV_INVALID	Argument name_dev specifies an invalid device
FS_ERR_DEV_NOT_OPEN	Device is not open.
FS_ERR_DEV_NOT_PRESENT	Device is not present.
FS_ERR_DEV_IO	Device I/O error.
FS_ERR_DEV_TIMEOUT	Device timeout.

RETURNED VALUE

None.

NOTES/WARNINGS

The device *must* be a NAND device (e.g., “**nand:0:**”).

Low-level unmounting clears software knowledge of the on-disk structures, forcing the device to again be low-level mounted or formatted prior to further use.

A-11 NOR DRIVER FUNCTIONS

void FSDev_NOR_LowFmt	(CPU_CHAR FS_ERR	*name_dev, *p_err);
void FSDev_NOR_LowMount	(CPU_CHAR FS_ERR	*name_dev, *p_err);
void FSDev_NOR_LowUnmount	(CPU_CHAR FS_ERR	*name_dev, *p_err);
void FSDev_NOR_LowCompact	(CPU_CHAR FS_ERR	*name_dev, *p_err);
void FSDev_NOR_LowDefrag	(CPU_CHAR FS_ERR	*name_dev, *p_err);
void FSDev_NOR_PhyRd	(CPU_CHAR void CPU_INT32U CPU_INT32U FS_ERR	*name_dev, *p_dest, start, cnt, *p_err);
void FSDev_NOR_PhyWr	(CPU_CHAR void CPU_INT32U CPU_INT32U FS_ERR	*name_dev, *p_src, start, cnt, *p_err);
void FSDev_NOR_PhyEraseBlk	(CPU_CHAR CPU_INT32U CPU_INT32U FS_ERR	*name_dev, start, size, *p_err);
void FSDev_NOR_PhyEraseChip	(CPU_CHAR FS_ERR	*name_dev, *p_err);

A-11-1 FSDev_NOR_LowFmt()

```
void FSDev_NOR_LowFmt (CPU_CHAR *name_dev,
                      FS_ERR   *p_err);
```

File	Called from	Code enabled by
fs_dev_nor.c	Application	N/A

Low-level format a NOR device.

ARGUMENTS

name_dev Device name (see Note).

p_err Pointer to variable that will the receive return error code from this function:

FS_ERR_NONE	Device low-level formatted successfully.
FS_ERR_NAME_NULL	Argument name_dev passed a NULL pointer.
FS_ERR_DEV_INVALID	Argument name_dev specifies an invalid device
FS_ERR_DEV_NOT_OPEN	Device is not open.
FS_ERR_DEV_NOT_PRESENT	Device is not present.
FS_ERR_DEV_INVALID_LOW_FMT	Device needs to be low-level formatted.
FS_ERR_DEV_IO	Device I/O error.
FS_ERR_DEV_TIMEOUT	Device timeout.

RETURNED VALUE

None.

NOTES/WARNINGS

The device *must* be a NOR device (e.g., “**nor:0:**”).

Low-level formatting associates physical areas (sectors) of the device with logical sector numbers. A NOR medium **MUST** be low-level formatted with this driver prior to access by the high-level file system, a requirement which the device module enforces.

A-11-2 FSDev_NOR_LowMount()

```
void FSDev_NOR_LowMount (CPU_CHAR *name_dev,  
                        FS_ERR *p_err);
```

File	Called from	Code enabled by
fs_dev_nor.c	Application	N/A

Low-level mount a NOR device.

ARGUMENTS

name_dev Device name (see Note).

p_err Pointer to variable that will the receive return error code from this function:

FS_ERR_NONE	Device low-level mounted successfully.
FS_ERR_NAME_NULL	Argument name_dev passed a NULL pointer.
FS_ERR_DEV_INVALID	Argument name_dev specifies an invalid device
FS_ERR_DEV_NOT_OPEN	Device is not open.
FS_ERR_DEV_NOT_PRESENT	Device is not present.
FS_ERR_DEV_INVALID_LOW_FMT	Device needs to be low-level formatted.
FS_ERR_DEV_IO	Device I/O error.
FS_ERR_DEV_TIMEOUT	Device timeout.

RETURNED VALUE

None.

NOTES/WARNINGS

The device *must* be a NOR device (e.g., “**nor:0:**”).

Low-level mounting parses the on-device structure, detecting the presence of a valid low-level format. If **FS_ERR_DEV_INVALID_LOW_FMT** is returned, the device is NOT low-level formatted.

A-11-3 FSDev_NOR_LowUnmount()

```
void FSDev_NOR_LowUnmount (CPU_CHAR *name_dev,
                          FS_ERR *p_err);
```

File	Called from	Code enabled by
fs_dev_nor.c	Application	N/A

Low-level unmount a NOR device.

ARGUMENTS

name_dev Device name (see Note).

p_err Pointer to variable that will the receive return error code from this function:

FS_ERR_NONE	Device low-level unmounted successfully.
FS_ERR_NAME_NULL	Argument name_dev passed a NULL pointer.
FS_ERR_DEV_INVALID	Argument name_dev specifies an invalid device
FS_ERR_DEV_NOT_OPEN	Device is not open.
FS_ERR_DEV_NOT_PRESENT	Device is not present.
FS_ERR_DEV_IO	Device I/O error.
FS_ERR_DEV_TIMEOUT	Device timeout.

RETURNED VALUE

None.

NOTES/WARNINGS

The device *must* be a NOR device (e.g., “**nor:0:**”).

Low-level unmounting clears software knowledge of the on-disk structures, forcing the device to again be low-level mounted or formatted prior to further use.

A-11-4 FSDev_NOR_LowCompact()

```
void FSDev_NOR_LowCompact (CPU_CHAR *name_dev,  
                           FS_ERR   *p_err);
```

File	Called from	Code enabled by
fs_dev_nor.c	Application	N/A

Low-level compact a NOR device.

ARGUMENTS

name_dev Device name (see Note).

p_err Pointer to variable that will the receive return error code from this function:

FS_ERR_NONE	Device low-level compacted successfully.
FS_ERR_NAME_NULL	Argument name_dev passed a NULL pointer.
FS_ERR_DEV_INVALID	Argument name_dev specifies an invalid device
FS_ERR_DEV_NOT_OPEN	Device is not open.
FS_ERR_DEV_NOT_PRESENT	Device is not present.
FS_ERR_DEV_INVALID_LOW_FMT	Device needs to be low-level formatted.
FS_ERR_DEV_IO	Device I/O error.
FS_ERR_DEV_TIMEOUT	Device timeout.

RETURNED VALUE

None.

NOTES/WARNINGS

The device *must* be a NOR device (e.g., “**nor:0:**”).

Compacting groups sectors containing high-level data into as few blocks as possible. If an image of a file system is to be formed for deployment, to be burned into chips for production, then it should be compacted after all files and directories are created.

A-11-5 FSDev_NOR_LowDefrag()

```
void FSDev_NOR_LowDefrag (CPU_CHAR *name_dev,
                          FS_ERR *p_err);
```

File	Called from	Code enabled by
fs_dev_nor.c	Application	N/A

Low-level defragment a NOR device.

ARGUMENTS

name_dev Device name (see Note).

p_err Pointer to variable that will the receive return error code from this function:

FS_ERR_NONE	Device low-level defragmented successfully.
FS_ERR_NAME_NULL	Argument name_dev passed a NULL pointer.
FS_ERR_DEV_INVALID	Argument name_dev specifies an invalid device
FS_ERR_DEV_NOT_OPEN	Device is not open.
FS_ERR_DEV_NOT_PRESENT	Device is not present.
FS_ERR_DEV_INVALID_LOW_FMT	Device needs to be low-level formatted.
FS_ERR_DEV_IO	Device I/O error.
FS_ERR_DEV_TIMEOUT	Device timeout.

RETURNED VALUE

None.

NOTES/WARNINGS

The device *must* be a NOR device (e.g., “nor:0:”).

Defragmentation groups sectors containing high-level data into as few blocks as possible, in order of logical sector. A defragmented file system should have near-optimal access speeds in a read-only environment.

A-11-6 FSDev_NOR_PhyRd()

```
void FSDev_NOR_PhyRd (CPU_CHAR   *name_dev,  
                     void        *p_dest,  
                     CPU_INT32U  start,  
                     CPU_INT32U  cnt,  
                     FS_ERR      *p_err);
```

File	Called from	Code enabled by
fs_dev_nor.c	Application	N/A

Read from a NOR device and store data in buffer.

ARGUMENTS

name_dev Device name (see Note).

p_dest Pointer to destination buffer.

start Start address of read (relative to start of device).

cnt Number of octets to read.

p_err Pointer to variable that will receive return error code from this function:

FS_ERR_NONE	Octets read successfully.
FS_ERR_NAME_NULL	Argument name_dev passed a NULL pointer.
FS_ERR_NULL_PTR	Argument p_dest passed a NULL pointer.
FS_ERR_DEV_INVALID	Argument name_dev specifies an invalid device.
FS_ERR_DEV_NOT_OPEN	Device is not open.
FS_ERR_DEV_NOT_PRESENT	Device is not present.
FS_ERR_DEV_INVALID_LOW_FMT	Device needs to be low-level formatted.
FS_ERR_DEV_IO	Device I/O error.
FS_ERR_DEV_TIMEOUT	Device timeout.

RETURNED VALUE

None.

NOTES/WARNINGS

The device *must* be a NOR device (e.g., “**nor:0:**”).

A-11-7 FSDev_NOR_PhyWr()

```
void FSDev_NOR_PhyWr (CPU_CHAR    *name_dev,  
                     void         *p_src,  
                     CPU_INT32U   start,  
                     CPU_INT32U   cnt,  
                     FS_ERR        *p_err);
```

File	Called from	Code enabled by
fs_dev_nor.c	Application	N/A

Write to a NOR device from a buffer.

ARGUMENTS

name_dev Device name (see Note).

p_src Pointer to source buffer.

start Start address of write (relative to start of device).

cnt Number of octets to write.

p_err Pointer to variable that will receive return error code from this function:

FS_ERR_NONE	Octets written successfully.
FS_ERR_NAME_NULL	Argument name_dev passed a NULL pointer.
FS_ERR_NULL_PTR	Argument p_src passed a NULL pointer.
FS_ERR_DEV_INVALID	Argument name_dev specifies an invalid device.
FS_ERR_DEV_NOT_OPEN	Device is not open.
FS_ERR_DEV_NOT_PRESENT	Device is not present.
FS_ERR_DEV_INVALID_LOW_FMT	Device needs to be low-level formatted.
FS_ERR_DEV_IO	Device I/O error.
FS_ERR_DEV_TIMEOUT	Device timeout.

RETURNED VALUE

None.

NOTES/WARNINGS

The device *must* be a NOR device (e.g., “**nor:0:**”).

Care should be taken if this function is used while a file system exists on the device, or if the device is low-level formatted. The octet location(s) modified are NOT validated as being outside any existing file system or low-level format information.

During a program operation, only 1 bits can be changed; a 0 bit cannot be changed to a 1. The application *must* know that the octets being programmed have not already been programmed.

A-11-8 FSDev_NOR_PhyEraseBlk()

```
void FSDev_NOR_PhyEraseBlk (CPU_CHAR    *name_dev,  
                             CPU_INT32U  start,  
                             CPU_INT32U  size,  
                             FS_ERR      *p_err);
```

File	Called from	Code enabled by
fs_dev_nor.c	Application	N/A

Erase block of NOR device.

ARGUMENTS

name_dev Device name (see Note).

start Start address of block (relative to start of device).

size Size of block, in octets.

p_err Pointer to variable that will receive return error code from this function:

FS_ERR_NONE	Block erased successfully.
FS_ERR_NAME_NULL	Argument name_dev passed a NULL pointer.
FS_ERR_DEV_INVALID	Argument name_dev specifies an invalid device
FS_ERR_DEV_NOT_OPEN	Device is not open.
FS_ERR_DEV_NOT_PRESENT	Device is not present.
FS_ERR_DEV_INVALID_LOW_FMT	Device needs to be low-level formatted.
FS_ERR_DEV_IO	Device I/O error.
FS_ERR_DEV_TIMEOUT	Device timeout.

RETURNED VALUE

None.

NOTES/WARNINGS

The device *must* be a NOR device (e.g., “**nor:0:**”).

Care should be taken if this function is used while a file system exists on the device, or if the device is low-level formatted. The erased block is NOT validated as being outside any existing file system or low-level format information.

A-11-9 FSDev_NOR_PhyEraseChip()

```
void FSDev_NOR_PhyEraseChip (CPU_CHAR *name_dev,  
                             FS_ERR   *p_err);
```

File	Called from	Code enabled by
fs_dev_nor.c	Application	N/A

Erase entire NOR device.

ARGUMENTS

name_dev Device name (see Note).

p_err Pointer to variable that will receive return error code from this function:

FS_ERR_NONE	Device erased successfully.
FS_ERR_NAME_NULL	Argument name_dev passed a NULL pointer.
FS_ERR_DEV_INVALID	Argument name_dev specifies an invalid device.
FS_ERR_DEV_NOT_OPEN	Device is not open.
FS_ERR_DEV_NOT_PRESENT	Device is not present.
FS_ERR_DEV_INVALID_LOW_FMT	Device needs to be low-level formatted.
FS_ERR_DEV_IO	Device I/O error.
FS_ERR_DEV_TIMEOUT	Device timeout.

RETURNED VALUE

None.

NOTES/WARNINGS

The device *must* be a NOR device (e.g., “**nor:0:**”).

This function should *not* be used while a file system exists on the device, or if the device is low-level formatted, unless the intent is to destroy all existing information.

A-12 FAT SYSTEM DRIVER FUNCTIONS

```
void
FS_FAT_JournalOpen (CPU_CHAR *name_vol,
                   FS_ERR *p_err);
```

```
void
FS_FAT_JournalClose (CPU_CHAR *name_vol,
                    FS_ERR *p_err);
```

```
void
FS_FAT_JournalStart (CPU_CHAR *name_vol,
                   FS_ERR *p_err);
```

```
void
FS_FAT_JournalStop (CPU_CHAR *name_vol,
                   FS_ERR *p_err);
```

```
void
FS_FAT_VolChk      (CPU_CHAR *name_vol,
                   FS_ERR *p_err);
```

A-12-1 FS_FAT_JournalOpen()

File	Called from	Code enabled by
fs_fat_journal.c	Application	FS_CFG_FAT_JOURNAL_EN

Open journal on volume.

ARGUMENTS

`name_vol` Volume name.

`p_err` Pointer to variable that will the receive return error code from this function:

`FS_ERR_NONE`

Journal opened.

`FS_ERR_DEV`

Device access error.

RETURNED VALUE

None.

NOTES/WARNINGS

None.

A-12-2 FS_FAT_JournalClose()

```
void FS_FAT_JournalClose (CPU_CHAR *name_vol,  
                          FS_ERR *p_err);
```

File	Called from	Code enabled by
fs_fat_journal.c	Application	FS_CFG_FAT_JOURNAL_EN

Close journal on volume.

ARGUMENTS

name_vol Volume name.

p_err Pointer to variable that will receive return error code from this function:

FS_ERR_NONE	Journal closed.
FS_ERR_DEV	Device access error.

RETURNED VALUE

None.

NOTES/WARNINGS

None.

A-12-3 FS_FAT_JournalStart()

```
void FS_FAT_JournalStart (CPU_CHAR *name_vol,  
                          FS_ERR *p_err);
```

File	Called from	Code enabled by
fs_fat_journal.c	Application	FS_CFG_FAT_JOURNAL_EN

Start journaling on volume.

ARGUMENTS

name_vol Volume name.

p_err Pointer to variable that will receive return error code from this function:

FS_ERR_NONE	Journaling started.
FS_ERR_DEV	Device access error.

RETURNED VALUE

None.

NOTES/WARNINGS

None.

A-12-4 FS_FAT_JournalStop()

```
void FS_FAT_JournalStop (CPU_CHAR *name_vol,  
                        FS_ERR *p_err);
```

File	Called from	Code enabled by
fs_fat_journal.c	Application	FS_CFG_FAT_JOURNAL_EN

Stop journaling on volume.

ARGUMENTS

name_vol Volume name.

p_err Pointer to variable that will the receive return error code from this function:

FS_ERR_NONE	Journaling stopped.
FS_ERR_DEV	Device access error.

RETURNED VALUE

None.

NOTES/WARNINGS

None.

A-12-5 FS_FAT_VolChk()

File	Called from	Code enabled by
fs_fat.c	Application	FS_CFG_FAT_VOL_CHK_EN

Check the file system on a volume.

ARGUMENTS

name_vol Volume name.

p_err Pointer to variable that will the receive return error code from this function:

FS_ERR_NONE	Volume checked without errors.
FS_ERR_NAME_NULL	Argument “name_vol” passed a null pointer.
FS_ERR_DEV	Device access error.
FS_ERR_VOL_NOT_OPEN	Volume not open.
FS_ERR_BUF_NONE_AVAIL	No buffers available.

RETURNED VALUE

None.

NOTES/WARNINGS

None.

B

µC/FS Error Codes

This appendix provides a brief explanation of µC/FS error codes defined in `fs_err.h`. Any error codes not listed here may be searched in `fs_err.h` for both their numerical value and usage.

B-1 SYSTEM ERROR CODES

<code>FS_ERR_NONE</code>	No error.
<code>FS_ERR_INVALID_ARG</code>	Invalid argument.
<code>FS_ERR_INVALID_CFG</code>	Invalid configuration.
<code>FS_ERR_INVALID_CHKSUM</code>	Invalid checksum.
<code>FS_ERR_INVALID_LEN</code>	Invalid length.
<code>FS_ERR_INVALID_TIME</code>	Invalid date/time.
<code>FS_ERR_INVALID_TIMESTAMP</code>	Invalid timestamp.
<code>FS_ERR_INVALID_TYPE</code>	Invalid object type.
<code>FS_ERR_MEM_ALLOC</code>	Mem could not be alloc'd.
<code>FS_ERR_NULL_ARG</code>	Arg(s) passed NULL val(s).
<code>FS_ERR_NULL_PTR</code>	Ptr arg(s) passed NULL ptr(s).
<code>FS_ERR_OS</code>	OS err.
<code>FS_ERR_OVF</code>	Value too large to be stored in type.
<code>FS_ERR_EOF</code>	EOF reached.
<code>FS_ERR_WORKING_DIR_NONE_AVAIL</code>	No working dir avail.
<code>FS_ERR_WORKING_DIR_INVALID</code>	Working dir invalid.

B-2 BUFFER ERROR CODES

<code>FS_ERR_BUF_NONE_AVAIL</code>	No buffer available.
------------------------------------	----------------------

B-3 CACHE ERROR CODES

<code>FS_ERR_CACHE_INVALID_MODE</code>	Mode specified invalid.
<code>FS_ERR_CACHE_INVALID_SEC_TYPE</code>	Device already open.
<code>FS_ERR_CACHE_TOO_SMALL</code>	Device has changed.

B-4 DEVICE ERROR CODES

<code>FS_ERR_DEV</code>	Device access error.
<code>FS_ERR_DEV_ALREADY_OPEN</code>	Device already open.
<code>FS_ERR_DEV_CHNGD</code>	Device has changed.
<code>FS_ERR_DEV_FIXED</code>	Device is fixed (cannot be closed).
<code>FS_ERR_DEV_FULL</code>	Device is full (no space could be allocated).
<code>FS_ERR_DEV_INVALID</code>	Invalid device.
<code>FS_ERR_DEV_INVALID_CFG</code>	Invalid dev cfg.
<code>FS_ERR_DEV_INVALID_ECC</code>	Invalid ECC.
<code>FS_ERR_DEV_INVALID_IO_CTRL</code>	I/O control invalid.
<code>FS_ERR_DEV_INVALID_LOW_FMT</code>	Low format invalid.
<code>FS_ERR_DEV_INVALID_LOW_PARAMS</code>	Invalid low-level device parameters.
<code>FS_ERR_DEV_INVALID_MARK</code>	Invalid mark.
<code>FS_ERR_DEV_INVALID_NAME</code>	Invalid device name.
<code>FS_ERR_DEV_INVALID_OP</code>	Invalid operation.
<code>FS_ERR_DEV_INVALID_SEC_NBR</code>	Invalid device sec nbr.
<code>FS_ERR_DEV_INVALID_SEC_SIZE</code>	Invalid device sec size.
<code>FS_ERR_DEV_INVALID_SIZE</code>	Invalid device size.
<code>FS_ERR_DEV_INVALID_UNIT_NBR</code>	Invalid device unit nbr.
<code>FS_ERR_DEV_IO</code>	Device I/O error.
<code>FS_ERR_DEV_NONE_AVAIL</code>	No device avail.
<code>FS_ERR_DEV_NOT_OPEN</code>	Device not open.
<code>FS_ERR_DEV_NOT_PRESENT</code>	Device not present.
<code>FS_ERR_DEV_TIMEOUT</code>	Device timeout.
<code>FS_ERR_DEV_UNIT_NONE_AVAIL</code>	No unit avail.
<code>FS_ERR_DEV_UNIT_ALREADY_EXIST</code>	Unit already exists.
<code>FS_ERR_DEV_UNKNOWN</code>	Unknown.
<code>FS_ERR_DEV_VOL_OPEN</code>	Vol open on dev.
<code>FS_ERR_DEV_INCOMPATIBLE_LOW_PARAMS</code>	Incompatible low-level device parameters.
<code>FS_ERR_DEV_INVALID_METADATA</code>	Device driver metadata is invalid.

FS_ERR_DEV_OP_ABORTED	Operation aborted.
FS_ERR_DEV_CORRUPT_LOW_FMT	Corrupted low-level fmt.
FS_ERR_DEV_INVALID_SEC_DATA	Retrieved sec data is invalid.
FS_ERR_DEV_WR_PROT	Device is write protected.
FS_ERR_DEV_OP_FAILED	Operation failed.
FS_ERR_DEV_NAND_NO_AVAIL_BLK	No <u>blk</u> avail.
FS_ERR_DEV_NAND_NO_SUCH_SEC	This sector is not available.
FS_ERR_DEV_NAND_ECC_NOT_SUPPORTED	The needed ECC scheme is not supported.
FS_ERR_DEV_NAND_ONFI_EXT_PARAM_PAGE	NAND device extended parameter page must be read.

B-5 DEVICE DRIVER ERROR CODES

FS_ERR_DEV_DRV_ALREADY_ADDED	Device driver already added.
FS_ERR_DEV_DRV_INVALID_NAME	Invalid device driver name.
FS_ERR_DEV_DRV_NONE_AVAIL	No driver available.

B-6 DIRECTORY ERROR CODES

FS_ERR_DIR_ALREADY_OPEN	Directory already open.
FS_ERR_DIR_DIS	Directory module disabled.
FS_ERR_DIR_FULL	Directory is full.
FS_ERR_DIR_NONE_AVAIL	No directory avail.
FS_ERR_DIR_NOT_OPEN	Directory not open.

B-7 ECC ERROR CODES

FS_ERR_ECC_CORRECTABLE	Correctable ECC error.
FS_ERR_ECC_UNCORRECTABLE	Uncorrectable ECC error.

B-8 ENTRY ERROR CODES

FS_ERR_ENTRIES_SAME	Paths specify same file system entry.
---------------------	---------------------------------------

<code>FS_ERR_ENTRIES_TYPE_DIFF</code>	Paths do not both specify files OR directories.
<code>FS_ERR_ENTRIES_VOLS_DIFF</code>	Paths specify file system entries on different vols.
<code>FS_ERR_ENTRY_CORRUPT</code>	File system entry is corrupt.
<code>FS_ERR_ENTRY_EXISTS</code>	File system entry exists.
<code>FS_ERR_ENTRY_INVALID</code>	File system entry invalid.
<code>FS_ERR_ENTRY_NOT_DIR</code>	File system entry NOT a directory.
<code>FS_ERR_ENTRY_NOT_EMPTY</code>	File system entry NOT empty.
<code>FS_ERR_ENTRY_NOT_FILE</code>	File system entry NOT a file.
<code>FS_ERR_ENTRY_NOT_FOUND</code>	File system entry NOT found.
<code>FS_ERR_ENTRY_PARENT_NOT_FOUND</code>	Entry parent NOT found.
<code>FS_ERR_ENTRY_PARENT_NOT_DIR</code>	Entry parent NOT a directory.
<code>FS_ERR_ENTRY_RD_ONLY</code>	File system entry marked read-only.
<code>FS_ERR_ENTRY_ROOT_DIR</code>	File system entry is a root directory.
<code>FS_ERR_ENTRY_TYPE_INVALID</code>	File system entry type is invalid.
<code>FS_ERR_ENTRY_OPEN</code>	Operation not allowed on entry corresponding to an open file/dir.

B-9 FILE ERROR CODES

<code>FS_ERR_FILE_ALREADY_OPEN</code>	File already open.
<code>FS_ERR_FILE_BUF_ALREADY_ASSIGNED</code>	Buf already assigned.
<code>FS_ERR_FILE_ERR</code>	Error indicator set on file.
<code>FS_ERR_FILE_INVALID_ACCESS_MODE</code>	Access mode is specified invalid.
<code>FS_ERR_FILE_INVALID_ATTRIB</code>	Attributes are specified invalid.
<code>FS_ERR_FILE_INVALID_BUF_MODE</code>	Buf mode is specified invalid or unknown.
<code>FS_ERR_FILE_INVALID_BUF_SIZE</code>	Buf size is specified invalid.
<code>FS_ERR_FILE_INVALID_DATE_TIME</code>	Date/time is specified invalid.
<code>FS_ERR_FILE_INVALID_DATE_TIME_FLAG</code>	Date/time flag is specified invalid.
<code>FS_ERR_FILE_INVALID_NAME</code>	Name is specified invalid.
<code>FS_ERR_FILE_INVALID_ORIGIN</code>	Origin is specified invalid or unknown.
<code>FS_ERR_FILE_INVALID_OFFSET</code>	Offset is specified invalid.
<code>FS_ERR_FILE_INVALID_FILES</code>	Invalid file arguments.
<code>FS_ERR_FILE_INVALID_OP</code>	File operation invalid.
<code>FS_ERR_FILE_INVALID_OP_SEQ</code>	File operation sequence invalid.
<code>FS_ERR_FILE_INVALID_POS</code>	File position invalid.
<code>FS_ERR_FILE_LOCKED</code>	File locked.

FS_ERR_FILE_NONE_AVAIL	No file available.
FS_ERR_FILE_NOT_OPEN	File NOT open.
FS_ERR_FILE_NOT_LOCKED	File NOT locked.
FS_ERR_FILE_OVF	File size overflowed max file size.
FS_ERR_FILE_OVF_OFFSET	File offset overflowed max file offset.

B-10 NAME ERROR CODES

FS_ERR_NAME_BASE_TOO_LONG	Base name too long.
FS_ERR_NAME_EMPTY	Name empty.
FS_ERR_NAME_EXT_TOO_LONG	Extension too long.
FS_ERR_NAME_INVALID	Invalid file name or path.
FS_ERR_NAME_MIXED_CASE	Name is mixed case.
FS_ERR_NAME_NULL	Name ptr arg(s) passed NULL ptr(s).
FS_ERR_NAME_PATH_TOO_LONG	Entry path is too long.
FS_ERR_NAME_BUF_TOO_SHORT	Buffer for name is too short.
FS_ERR_NAME_TOO_LONG	Full name is too long.

B-11 PARTITION ERROR CODES

FS_ERR_PARTITION_INVALID	Partition invalid.
FS_ERR_PARTITION_INVALID_NBR	Partition nbr specified invalid.
FS_ERR_PARTITION_INVALID_SIG	Partition sig invalid.
FS_ERR_PARTITION_INVALID_SIZE	Partition size invalid.
FS_ERR_PARTITION_MAX	Max nbr partitions have been created in MBR.
FS_ERR_PARTITION_NOT_FINAL	Prev partition is not final partition.
FS_ERR_PARTITION_NOT_FOUND	Partition NOT found.
FS_ERR_PARTITION_ZERO	Partition zero.

B-12 POOLS ERROR CODES

FS_ERR_POOL_EMPTY	Pool is empty.
FS_ERR_POOL_FULL	Pool is full.
FS_ERR_POOL_INVALID_BLK_ADDR	Block not found in used pool pointers.
FS_ERR_POOL_INVALID_BLK_IN_POOL	Block found in free pool pointers.

FS_ERR_POOL_INVALID_BLK_IX	Block index invalid.
FS_ERR_POOL_INVALID_BLK_NBR	Number blocks specified invalid.
FS_ERR_POOL_INVALID_BLK_SIZE	Block size specified invalid.

B-13 FILE SYSTEM ERROR CODES

FS_ERR_SYS_TYPE_NOT_SUPPORTED	File sys type not supported.
FS_ERR_SYS_INVALID_SIG	Sec has invalid OR illegal sig.
FS_ERR_SYS_DIR_ENTRY_PLACE	Dir entry could not be placed.
FS_ERR_SYS_DIR_ENTRY_NOT_FOUND	Dir entry not found.
FS_ERR_SYS_DIR_ENTRY_NOT_FOUND_YET	Dir entry not found (yet).
FS_ERR_SYS_SEC_NOT_FOUND	Sec not found.
FS_ERR_SYS_CLUS_CHAIN_END	Cluster chain ended.
FS_ERR_SYS_CLUS_CHAIN_END_EARLY	Cluster chain ended before number clusters traversed.
FS_ERR_SYS_CLUS_INVALID	Cluster invalid.
FS_ERR_SYS_CLUS_NOT_AVAIL	Cluster not avail.
FS_ERR_SYS_SFN_NOT_AVAIL	SFN is not avail.
FS_ERR_SYS_LFN_ORPHANED	LFN entry orphaned.

B-14 VOLUME ERROR CODES

FS_ERR_VOL_INVALID_NAME	Invalid volume name.
FS_ERR_VOL_INVALID_SIZE	Invalid volume size.
FS_ERR_VOL_INVALID_SEC_SIZE	Invalid volume sector size.
FS_ERR_VOL_INVALID_CLUS_SIZE	Invalid volume cluster size.
FS_ERR_VOL_INVALID_OP	Volume operation invalid.
FS_ERR_VOL_INVALID_SEC_NBR	Invalid volume sector number.
FS_ERR_VOL_INVALID_SYS	Invalid file system on volume.
FS_ERR_VOL_NO_CACHE	No cache assigned to volume.
FS_ERR_VOL_NONE_AVAIL	No vol avail.
FS_ERR_VOL_NONE_EXIST	No vols exist.
FS_ERR_VOL_NOT_OPEN	Vol NOT open.
FS_ERR_VOL_NOT_MOUNTED	Vol NOT mounted.
FS_ERR_VOL_ALREADY_OPEN	Vol already open.
FS_ERR_VOL_FILES_OPEN	Files open on vol.

FS_ERR_VOL_DIRS_OPEN	Dirs open on vol.
FS_ERR_JOURNAL_ALREADY_OPEN	Journal already open.
FS_ERR_JOURNAL_CFG_CHANGED	File system suite cfg changed since log created.
FS_ERR_JOURNAL_FILE_INVALID	Journal file invalid.
FS_ERR_JOURNAL_FULL	Journal full.
FS_ERR_JOURNAL_LOG_INVALID_ARG	Invalid arg read from journal log.
FS_ERR_JOURNAL_LOG_INCOMPLETE	Log not completely entered in journal.
FS_ERR_JOURNAL_LOG_NOT_PRESENT	Log not present in journal.
FS_ERR_JOURNAL_NOT_OPEN	Journal not open
FS_ERR_JOURNAL_NOT_REPLAYING	Journal not being replayed.
FS_ERR_JOURNAL_NOT_STARTED	Journaling not started.
FS_ERR_JOURNAL_NOT_STOPPED	Journaling not stopped.
FS_ERR_VOL_LABEL_INVALID	Volume label is invalid.
FS_ERR_VOL_LABEL_NOT_FOUND	Volume label was not found.
FS_ERR_VOL_LABEL_TOO_LONG	Volume label is too long.

B-15 OS LAYER ERROR CODES

FS_ERR_OS_LOCK	Lock not acquired.
FS_ERR_OS_INIT	OS not initialized.
FS_ERR_OS_INIT_LOCK	Lock signal not successfully initialized.
FS_ERR_OS_INIT_LOCK_NAME	Lock signal name not successfully initialized.

C

μC/FS Porting Manual

μC/FS adapts to its environment via a number of ports. The simplest ones, common to all installations, interface with the application, OS kernel (if any) and CPU. More complicated may be ports to media drivers, which require additional testing, validation and optimization; but many of those are still straightforward. Figure C-1 diagrams the relationship between μC/FS and external modules and hardware.

The sections in this chapter describe each require function and give hints for implementers. Anyone creating a new port should first check the example ports are included in the μC/FS distribution in the following directory:

```
\Micrium\Software\uC-FS\Examples\BSP\Dev
```

The port being contemplated may already exist; failing that, some similar CPU/device may have already be supported.

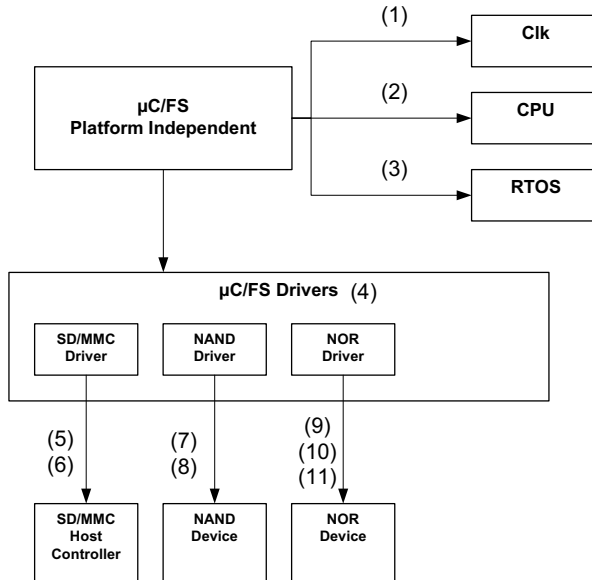

Figure C-1 μC/FS ports architecture

- FC-1(1) μC/Clk act as a centralized clock management module. If you use an external real-time clock, you will have to write functions to let μC/FS know the date and time.
- FC-1(2) The CPU port (within μC/CPU) adapts the file system suite to the CPU and compiler characteristics. The fixed-width types (e.g., CPU_INT16U) used in the file system suite are defined here.
- FC-1(3) The RTOS port adapts the file system suite to the OS kernel (if any) included in the application. The files FS_OS.C/H contain functions primarily aimed at making accesses to devices and critical information in memory thread-safe.
- FC-1(4) μC/FS interfaces with memory devices through drivers following a generic driver model. It is possible to create a driver for a different type of device from this model/template.
- FC-1(5) The SD/MMC driver can be ported to any SD/MMC host controller for cardmode access.

-
- FC-1(6) The SD/MMC driver can be ported to any SPI peripheral for SPI mode access.
 - FC-1(7) The NAND driver can be ported for many physical organizations (page size, bus width, SLC/MLC, etc.).
 - FC-1(8) The NAND driver can be ported to any bus interface. A NAND device can also be located directly on GPIO and accessed by direct toggling of port pins.
 - FC-1(9) The NOR driver can be ported to many physical organization (command set, bus type, etc.).
 - FC-1(10) The NOR driver can be ported to any bus interface.
 - FC-1(11) The NOR driver can be ported to any SPI peripheral (for SPI flash).

C-1 DATE/TIME MANAGEMENT

Depending on the settings of μ C/Clk, you might have to write time management functions that are specific to your application. For example, you might have to define the function `Clk_ExtTS_Get()` to obtain the timestamp of your system provided by a real-time clock peripheral. Please refer to μ C/Clk manual for more details.

C-2 CPU PORT

μ C/CPU is a processor/compiler port needed for μ C/FS to be CPU/compiler-independant. Ports for the most popular architectures are already available in the μ C/CPU distribution. If the μ C/CPU port for your target architecture is not available, you should create your own based on the port template (also available in μ C/CPU distribution). You should refer to the μ C/CPU user manual to know how you should use it in your project.

C-3 OS KERNEL

µC/FS can be used with or without an RTOS. Either way, an OS port must be included in your project. The port includes one code/header file pair:

```
fs_os.c  
fs_os.h
```

µC/FS manages devices and data structures that may not be accessed by several tasks simultaneously. An OS kernel port leverages the kernel's mutual exclusion services (mutexes) for that purpose.

These files are generally placed in a directory named according to the following rubric:

```
\Micrium\Software\uC-FS\OS\
```

Four sets of files are included with the µC/FS distribution:

\Micrium\Software\uC-FS\OS\Template	Template
\Micrium\Software\uC-FS\OS\None	No OS kernel port
\Micrium\Software\uC-FS\OS\µCOS-II	µC/OS-II port
\Micrium\Software\uC-FS\OS\µCOS-III	µC/OS-III port

If you don't use any OS (including a custom in-house OS), you should include the port for no OS in your project. You must also make sure that you manage interrupts correctly.

If you are using µC/OS-II or µC/OS-III, you should include the appropriate ports in your project. If you use another OS, you should create your own port based on the template. The functions that need to be written in this port are described here.

FS_OS_Init(), FS_OS_Lock() and FS_OS_Unlock()

The core data structures are protected by a single mutex. **FS_OS_Init()** creates this semaphore. **FS_OS_Lock()** and **FS_OS_Unlock()** acquire and release the resource. Lock operations are never nested.

FS_OS_DevInit(), FS_OS_DevLock() and FS_OS_DevUnlock()

File system device, generally, do not tolerate multiple simultaneous accesses. A different mutex controls access to each device and information about it in RAM. `FS_OS_DevInit()` creates one mutex for each possible device. `FS_OS_DevLock()` and `FS_OS_DevUnlock()` acquire and release access to a specific device. Lock operations for the same device are never nested.

FS_OS_FileInit(), FS_OS_FileAccept(), FS_OS_FileLock() and FS_OS_FileUnlock()

Multiple calls to file access functions may be required for a file operation that must be guaranteed atomic. For example, a file may be a conduit of data from one task to several. If a data entry cannot be read in a single file read, some lock is necessary to prevent preemption by another consumer. File locks, represented by API functions like `FSFile_LockGet()` and `flockfile()`, provide a solution. Four functions implement the actual lock in the OS port. `FS_OS_FileInit()` creates one mutex for each possible file. `FS_OS_FileLock()/FS_OS_FileAccept()` and `FS_OS_FileUnlock()` acquire and release access to a specific file. Lock operations for the same file MAY be nested, so the implementations must be able to determine whether the active task owns the mutex. If it does, then an associated lock count should be incremented; otherwise, it should try to acquire the resource as normal.

FS_OS_WorkingDirGet() and FS_OS_WorkingDirSet()

File and directory paths are typically interpreted absolutely; they must start at the root directory, specifying every intermediate path component. If much work will be accomplished upon files in a certain directory or a task requires a root directory as part of its context, working directories are valuable. Once a working directory is set for a task, subsequent non-absolute paths will be interpreted relative to the set directory.

```

#if (FS_CFG_WORKING_DIR_EN == DEF_ENABLED)
CPU_CHAR *FS_OS_WorkingDirGet (void)                                     (1)
{
    OS_ERR      os_err;
    CPU_INT32U  reg_val;
    CPU_CHAR    *p_working_dir;
    reg_val = OSTaskRegGet((OS_TCB *) 0,
                           FS_OS_REG_ID_WORKING_DIR,
                           &os_err);

    if (os_err != OS_ERR_NONE) {
        reg_val = 0u;
    }
    p_working_dir = (CPU_CHAR *)reg_val;
    return (p_working_dir);
}
#endif
#if (FS_CFG_WORKING_DIR_EN == DEF_ENABLED)
void FS_OS_WorkingDirSet (CPU_CHAR *p_working_dir,
                          FS_ERR    *p_err)
{
    OS_ERR      os_err;
    CPU_INT32U  reg_val;
    reg_val = (CPU_INT32U)p_working_dir;
    OSTaskRegSet((OS_TCB *) 0,
                  FS_OS_RegIdWorkingDir,
                  (OS_REG)  reg_val,
                  &os_err);

    if (os_err != OS_ERR_NONE) {
        *p_err = FS_ERR_OS;
        return;
    }
    *p_err = FS_ERR_NONE;
}
#endif

```

Listing C-1 **FS_OS_WorkingDirGet()/Set()** (μ C/OS-III)

LC-1(1) **FS_OS_WorkingDirGet()** gets the pointer to the working directory associated with the active task. In μ C/OS-III, the pointer is stored in one of the task registers, a set of software data that is part of the task context (just like hardware register values). The implementation casts the integral register value to a pointer to a character. If no working directory has been assigned, the return value must be a pointer to NULL. In the case of μ C/OS-III, that will be done because the register values are cleared upon task creation.

-
- LC-1(2) **FS_OS_WorkingDirSet()** associates a working directory with the active task. The pointer is cast to the integral register data type and stored in a task register.

The application calls either of the core file system functions **FS_WorkingDirSet()** or **fs_chdir()** to set the working directory. The core function forms the full path of the working directory and “saves” it with the OS port function **FS_OS_WorkingDirSet()**. The port function should associate it with the task in some manner so that it can be retrieved with **FS_OS_WorkingDirGet()** even after many context switches have occurred.

```
#if (FS_CFG_WORKING_DIR_EN == DEF_ENABLED)
void FS_OS_WorkingDirFree (OS_TCB *p_tcb)
{
    OS_ERR      os_err;
    CPU_INT32U  reg_val;
    CPU_CHAR    *path_buf;
    reg_val = OSTaskRegGet( p_tcb,
                           FS_OS_REG_ID_WORKING_DIR,
                           &os_err);
    if (os_err != OS_ERR_NONE) {
        return;
    }
    if (reg_val == 0u) {
        return;
    }
    path_buf = (CPU_CHAR *)reg_val;
    FS_WorkingDirObjFree(path_buf);
}
#endif
```

Listing C-2 **FS_OS_WorkingDirFree()** (μ C/OS-III)

- LC-2(1) If the register value is zero, no working directory has been assigned and no action need be taken.
- LC-2(2) **FS_WorkingDirObjFree()** frees the working directory object to the working directory pool. If this were not done, the unfreed object would constitute a memory leak that could deplete the heap memory eventually.

The character string for the working directory is allocated from the μ C/LIB heap. If a task is deleted, it must be freed (made available for future allocation) to avert a crippling memory leak. The internal file system function `FS_WorkingDirObjFree()` releases the string to an object pool. In the port for μ C/OS-III, that function is called by `FS_OS_WorkingDirFree()` which must be called by the assigned task delete hook.

FS_OS_Dly_ms()

Device drivers and example device driver ports delay task execution `FS_OS_Dly_ms()`. Common functions allow BSP developers to optimize implementation easily. A millisecond delay may be accomplished with an OS kernel service, if available. The trivial implementation of a delay (particularly a sub-millisecond delay) is a while loop; better performance may be achieved with hardware timers with semaphores for wait and asynchronous notification. The best solution will vary from one platform to another, since the additional context switches may prove burdensome. No matter which strategy is selected, the function **MUST** delay for at least the specified time amount; otherwise, sporadic errors can occur. Ideally, the actual time delay will equal the specified time amount to avoid wasting processor cycles.

```
void FS_BSP_Dly_ms (CPU_INT16U ms)
{
    /* $$$$ Insert code to delay for specified number of millieconds. */
}
```

Listing C-3 **FS_OS_Dly_ms()**

FS_OS_Sem####()

The four generic OS semaphore functions provide a complete abstraction of a basic OS kernel service. `FS_OS_SemCreate()` creates a semaphore which may later be deleted with `FS_OS_SemDel()`. `FS_OS_SemPost()` signals the semaphore (with or without timeout) and `FS_OS_SemPend()` waits until the semaphore is signaled. On systems without an OS kernel, the trivial implementations in Listing C-4 are recommended.

```

CPU_BOOLEAN FS_OS_SemCreate (FS_BSP_SEM *p_sem,           (1)
                             CPU_INT16U  cnt)
{
    *p_sem = cnt;           /* $$$$ Create semaphore with initial count 'cnt'. */
    return (DEF_OK);
}
CPU_BOOLEAN FS_OS_SemDel (FS_BSP_SEM *p_sem)             (2)
{
    *p_sem = 0u;         /* $$$$ Delete semaphore. */
    return (DEF_OK);
}

```

Listing C-4 **FS_OS_Sem####()** trivial implementations

```

CPU_BOOLEAN FS_OS_SemPend (FS_BSP_SEM *p_sem,          (3)
                          CPU_INT32U  timeout)
{
    CPU_INT32U  timeout_cnts;
    CPU_INT16U  sem_val;
    CPU_SR_ALLOC();
    if (timeout == 0u) {
        sem_val = 0u;
        while (sem_val == 0u) {
            CPU_CRITICAL_ENTER();
            sem_val = *p_sem;          /* $$$$ If semaphore available ... */
            if (sem_val > 0u) {
                *p_sem = sem_val - 1u; /* ... decrement semaphore count. */
            }
            CPU_CRITICAL_EXIT();
        }
    } else {
        timeout_cnts = timeout * FS_BSP_CNTPS_PER_MS;
        sem_val = 0;
        while ((timeout_cnts > 0u) &&
              (sem_val == 0u)) {
            CPU_CRITICAL_ENTER();
            sem_val = *p_sem;          /* $$$$ If semaphore available ... */
            if (sem_val > 0) {
                *p_sem = sem_val - 1u; /* ... decrement semaphore count. */
            }
            CPU_CRITICAL_EXIT();
            timeout_cnts--;
        }
    }
    if (sem_val == 0u) {
        return (DEF_FAIL);
    } else {
        return (DEF_OK);
    }
}

```

Listing C-5 **FS_OS_Sem####()** trivial implementations (continued)

LC-5(1) **FS_OS_SemCreate()** creates a semaphore in the variable `p_sem`. For this trivial implementation, **FS_BSP_SEM** is a integer type which stores the current count, i.e., the number of objects available.

LC-5(2) **FS_OS_SemDel()** deletes a semaphore created by **FS_OS_SemCreate()**.

```
CPU_BOOLEAN FS_OS_SemPost (FS_BSP_SEM *p_sem) (4)
{
    CPU_INT16U sem_val;
    CPU_SR_ALLOC();
    CPU_CRITICAL_ENTER();
    sem_val = *p_sem;          /* $$$$ Increment semaphore value. */
    sem_val++;
    *p_sem = sem_val;
    CPU_CRITICAL_EXIT();
    return (DEF_OK);
}
```

Listing C-6 **FS_OS_Sem####()** trivial implementations (continued)

LC-6(3) **FS_OS_SemPend()** waits until a semaphore is signaled. If a zero timeout is given, the wait is possibly infinite (it never times out).

LC-6(4) **FS_OS_SemPost()** signals a semaphore.

C-4 DEVICE DRIVER

Devices drivers for the most popular devices are already available for μ C/FS. If you use a particular device for which no driver exist, you should read this section to understand how to build your own driver.

A device driver is registered with the file system by passing a pointer to its API structure as the first parameter of `FS_DrvAdd()`. The API structure, `FS_DEV_API`, includes pointers to eight functions used to control and access the device:

```
const FS_DEV_API FSDev_#### = {
    FSDev_####_NameGet,
    FSDev_####_Init,
    FSDev_####_Open,
    FSDev_####_Close,
    FSDev_####_Rd,
    #if (FS_CFG_RD_ONLY_EN == DEF_DISABLED)
        FSDev_####_Wr,
    #endif
    FSDev_####_Query,
    FSDev_####_IO_Ctrl
};
```

The functions which must be implemented are listed and described in Table C-1. The first two functions, `NameGet()` and `Init()`, act upon the driver as a whole; neither should interact with any physical devices. The remaining functions act upon individual devices, and the first argument of each is a pointer to a `FS_DEV` structure which holds device information, including the unit number which uniquely identifies the device unit (member `UnitNbr`).

Function	Description
NameGet()	Get driver name.
Init()	Initialize driver.
Open()	Open a device.
Close()	Close a device.
Rd()	Read from a device.
Wr()	Write to a device.
Query()	Get information about a device.
IO_Ctrl()	Execute device I/O control operation.

Table C-1 **Device driver API functions**

C-4-1 NameGet()

```
static const CPU_CHAR *FSDev_####_NameGet (void);
```

File	Called from	Code enabled by
fs_dev_####.c	various	N/A

Device drivers are identified by unique names, on which device names are based. For example, the unique name for the NAND flash driver is “nand”; the NAND devices will be named “nand:0:”, “nand:1:”, etc.

ARGUMENTS

None.

RETURNED VALUE

Pointer to the device driver name.

NOTES/WARNINGS

- 1 The name *must not* include the ‘:’ character.
- 2 The name *must* be constant; each time this function is called, the same name MUST be returned.
- 3 The device driver `NameGet()` function is called while the caller holds the FS lock.

C-4-2 Init()

```
static void FSDev_####_Init (void);
```

File	Called from	Code enabled by
fs_dev_####.c	FS_DevDrvAdd()	N/A

The device driver `Init()` function should initialize any structures, tables or variables that are common to all devices or are used to manage devices accessed with the driver. This function *should not* initialize any devices; that will be done individually for each with the device driver's `Open()` function.

ARGUMENTS

None.

RETURNED VALUE

None.

NOTES/WARNINGS

- 1 The device driver `Init()` function is called while the caller holds the FS lock.

C-4-3 Open()

```
static void FSDev_####_Open (FS_DEV *p_dev,
                             void *p_dev_cfg,
                             FS_ERR *p_err);
```

File	Called from	Code enabled by
fs_dev_####.c	FSDev_Open()	N/A

The device driver `Open()` function should initialize the hardware to access a device and attempt to initialize that device. If this function is successful (i.e., it returns `FS_ERR_NONE`), then the file system suite expects the device to be ready for read and write accesses.

ARGUMENTS

`p_dev` Pointer to device to open.

`p_dev_cfg` Pointer to device configuration.

`p_err` Pointer to variable that will receive the return error code from this function:

<code>FS_ERR_NONE</code>	Device opened successfully.
<code>FS_ERR_DEV_ALREADY_OPEN</code>	Device unit is already opened.
<code>FS_ERR_DEV_INVALID_CFG</code>	Device configuration specified invalid.
<code>FS_ERR_DEV_INVALID_LOW_FMT</code>	Device needs to be low-level formatted.
<code>FS_ERR_DEV_INVALID_LOW_PARAMS</code>	Device low-level device parameters invalid.
<code>FS_ERR_DEV_INVALID_UNIT_NBR</code>	Device unit number is invalid.
<code>FS_ERR_DEV_IO</code>	Device I/O error.
<code>FS_ERR_DEV_NOT_PRESENT</code>	Device unit is not present.
<code>FS_ERR_DEV_TIMEOUT</code>	Device timeout.
<code>FS_ERR_MEM_ALLOC</code>	Memory could not be allocated.

RETURNED VALUE

None.

NOTES/WARNINGS

- 1 Tracking whether a device is open is not necessary, because this should NEVER be called when a device is already open.
- 2 Some drivers may need to track whether a device has been previously opened (indicating that the hardware has previously been initialized).
- 3 This will be called *every* time the device is opened.
- 4 The driver should identify the device instance to be opened by checking `p_dev->UnitNbr`. For example, if “template:2.” is to be opened, then `p_dev->UnitNbr` will hold the integer 2.
- 5 The device driver `Open()` function is called while the caller holds the device lock.

C-4-4 Close()

```
static void FSDev_####_Close (FS_DEV *p_dev);
```

File	Called from	Code enabled by
fs_dev_####.c	FSDev_Close()	N/A

The device driver `Close()` function should uninitialized the hardware and release or free any resources acquired in the `Open()` function.

ARGUMENTS

`p_dev` Pointer to device to close.

RETURNED VALUE

None.

NOTES/WARNINGS

- 1 Tracking whether a device is open is not necessary, because this should ONLY be called when a device is open.
- 2 This will be called EVERY time the device is closed.
- 3 The device driver `Close()` function is called while the caller holds the device lock.

C-4-5 Rd()

```
static void FSDev_####_Rd (FS_DEV      *p_dev,  
                           void        *p_dest,  
                           FS_SEC_NBR  start,  
                           FS_SEC_QTY  cnt,  
                           FS_ERR      *p_err);
```

File	Called from	Code enabled by
fs_dev_####.c	FSDev_RdLocked()	N/A

The device driver `Rd()` function should read from a device and store data in a buffer. If an error is returned, the file system suite assumes that no data is read; if not all data can be read, an error MUST be returned.

ARGUMENTS

`p_dev` Pointer to device to read from.

`p_dest` Pointer to destination buffer.

`start` Start sector of read.

`cnt` Number of sectors to read

`p_err` Pointer to variable that will receive the return error code from this function

<code>FS_ERR_NONE</code>	Sector(s) read.
<code>FS_ERR_DEV_INVALID_UNIT_NBR</code>	Device unit number is invalid.
<code>FS_ERR_DEV_IO</code>	Device I/O error.
<code>FS_ERR_DEV_NOT_OPEN</code>	Device is not open.
<code>FS_ERR_DEV_NOT_PRESENT</code>	Device is not present.
<code>FS_ERR_DEV_TIMEOUT</code>	Device timeout.

RETURNED VALUE

None.

NOTES/WARNINGS

- 1 Tracking whether a device is open is not necessary, because this should *only* be called when a device is open.
- 2 The device driver **Rd()** function is called while the caller holds the device lock.

C-4-6 Wr()

```
static void FSDev_####_Wr (FS_DEV      *p_dev,  
                           void        *p_src,  
                           FS_SEC_NBR  start,  
                           FS_SEC_QTY  cnt,  
                           FS_ERR      *p_err);
```

File	Called from	Code enabled by
fs_dev_####.c	FSDev_WrLocked()	N/A

The device driver `Wr()` function should write to a device the data from a buffer. If an error is returned, the file system suite assumes that no data has been written.

ARGUMENTS

`p_dev` Pointer to device to write to.

`p_src` Pointer to source buffer.

`start` Start sector of write.

`cnt` Number of sectors to write

`p_err` Pointer to variable that will receive the return error code from this function

<code>FS_ERR_NONE</code>	Sector(s) written.
<code>FS_ERR_DEV_INVALID_UNIT_NBR</code>	Device unit number is invalid.
<code>FS_ERR_DEV_IO</code>	Device I/O error.
<code>FS_ERR_DEV_NOT_OPEN</code>	Device is not open.
<code>FS_ERR_DEV_NOT_PRESENT</code>	Device is not present.
<code>FS_ERR_DEV_TIMEOUT</code>	Device timeout.

RETURNED VALUE

None.

NOTES/WARNINGS

- 1 Tracking whether a device is open is not necessary, because this should *only* be called when a device is open.
- 2 The device driver `Wr()` function is called while the caller holds the device lock.

C-4-7 Query()

```
static void FSDev_####_Query (FS_DEV      *p_dev,  
                             FS_DEV_INFO *p_info,  
                             FS_ERR       *p_err);
```

File	Called from	Code enabled by
fs_dev_####.c	FSDev_Open(), FSDev_Refresh(), FSDev_QueryLocked()	N/A

The device driver `Query()` function gets information about a device.

ARGUMENTS

`p_dev` Pointer to device to query.

`p_info` Pointer to structure that will receive device information.

`p_err` Pointer to variable that will receive the return error code from this function

<code>FS_ERR_NONE</code>	Device information obtained.
<code>FS_ERR_DEV_INVALID_UNIT_NBR</code>	Device unit number is invalid.
<code>FS_ERR_DEV_NOT_OPEN</code>	Device is not open.
<code>FS_ERR_DEV_NOT_PRESENT</code>	Device is not present.

RETURNED VALUE

None.

NOTES/WARNINGS

- 1 Tracking whether a device is open is not necessary, because this should ONLY be called when a device is open.
- 2 The device driver `Query()` function is called while the caller holds the device lock.

For more information about the `FS_DEV_INFO` structure, see section D-2 “`FS_DEV_INFO`” on page 484.

C-4-8 IO_Ctrl()

```
static void FSDev_####_IO_Ctrl (FS_DEV          *p_dev,
                                FS_IO_CTRL_CMD  cmd,
                                Void           *p_buf,
                                FS_ERR         *p_err);
```

File	Called from	Code enabled by
fs_dev_####.c	various	N/A

The device driver `IO_Ctrl()` function performs an I/O control operation.

ARGUMENTS

`p_dev` Pointer to device to query.

`p_buf` Buffer which holds data to be used for operations

OR

Buffer in which data will be stored as a result of operation.

`p_err` Pointer to variable that will receive the return error code from this function

<code>FS_ERR_NONE</code>	Control operation performed successfully.
<code>FS_ERR_DEV_INVALID_IO_CTRL</code>	I/O control operation unknown to driver.
<code>FS_ERR_DEV_INVALID_UNIT_NBR</code>	Device unit number is invalid.
<code>FS_ERR_DEV_IO</code>	Device I/O error.
<code>FS_ERR_DEV_NOT_OPEN</code>	Device is not open.
<code>FS_ERR_DEV_NOT_PRESENT</code>	Device is not present.
<code>FS_ERR_DEV_TIMEOUT</code>	Device timeout.

RETURNED VALUE

None.

NOTES/WARNINGS

- 1 Tracking whether a device is open is not necessary, because this should ONLY be called when a device is open.
- 2 Defined I/O control operations are
 - a. `FS_DEV_IO_CTRL_REFRESH` Refresh device.
 - b. `FS_DEV_IO_CTRL_LOW_FMT` Low-level format device.
 - c. `FS_DEV_IO_CTRL_LOW_MOUNT` Low-level mount device.
 - d. `FS_DEV_IO_CTRL_LOW_UNMOUNT` Low-level unmount device.
 - e. `FS_DEV_IO_CTRL_LOW_COMPACT` Low-level compact device.
 - f. `FS_DEV_IO_CTRL_LOW_DEFRAG` Low-level defragment device.
 - g. `FS_DEV_IO_CTRL_SEC_RELEASE` Release data in sector
 - h. `FS_DEV_IO_CTRL_PHY_RD` Read physical device
 - i. `FS_DEV_IO_CTRL_PHY_WR` Write physical device
 - j. `FS_DEV_IO_CTRL_PHY_RD_PAGE` Read physical device page
 - k. `FS_DEV_IO_CTRL_PHY_WR_PAGE` Write physical device page
 - l. `FS_DEV_IO_CTRL_PHY_ERASE_BLK` Erase physical device block
 - m. `FS_DEV_IO_CTRL_PHY_ERASE_CHIP` Erase physical device

Not all of these operations are valid for all devices.

The device driver `IO_Ctrl()` function is called while the caller holds the device lock.

C-5 SD/MMC CARDMODE BSP

The SD/MMC cardmode protocol is unique to SD- and MMC-compliant devices. The generic driver handles the peculiarities for initializing, reading and writing a card (including state transitions and error handling), but each CPU has a different host controller that must be individually ported. To that end, a BSP, supplementary to the general μ C/FS BSP, is required that abstracts the SD/MMC interface. The port includes one code file:

`FS_DEV_SD_CARD_BSP.C`

This file is generally placed with other BSP files in a directory named according to the following rubric:

```
\Micrium\Software\EvalBoards\<<manufacturer>\<board_name>
\<compiler>\BSP\
```

Several example ports are included in the μ C/FS distribution in files named according to the following rubric:

```
\Micrium\Software\uC-FS\Examples\BSP\Dev\SD\Card\<<cpu_name>
```

Function	Description
FSDev_SD_Card_BSP_Open()	Open (initialize) SD/MMC card interface.
FSDev_SD_Card_BSP_Close()	Close (uninitialize) SD/MMC card interface.
FSDev_SD_Card_BSP_Lock()	Acquire SD/MMC card bus lock.
FSDev_SD_Card_BSP_Unlock()	Release SD/MMC card bus lock.
FSDev_SD_Card_BSP_CmdStart()	Start a command.
FSDev_SD_Card_BSP_CmdWaitEnd()	Wait for a command to end and get response.
FSDev_SD_Card_BSP_CmdDataRd()	Read data following command.
FSDev_SD_Card_BSP_CmdDataWr()	Write data following command.
FSDev_SD_Card_BSP_GetBlkCntMax()	Get max block count.
FSDev_SD_Card_BSP_GetBusWidthMax()	Get maximum bus width, in bits.
FSDev_SD_Card_BSP_SetBusWidth()	Set bus width.
FSDev_SD_Card_BSP_SetClkFreq()	Set clock frequency.
FSDev_SD_Card_BSP_SetTimeoutData()	Set data timeout.
FSDev_SD_Card_BSP_SetTimeoutResp()	Set response timeout.

Table C-2 **SD/MMC cardmode BSP functions**

Each BSP must implement the functions in Table C-2. (For information about creating a port for a platform accessing a SD/MMC device in SPI mode, see section C-6 “SD/MMC SPI mode BSP” on page 452) This software interface was designed by reviewing common host implementations as well as the SD card association’s SD Specification Part A2 – SD Host Controller Simplified Specification, Version 2.00, which recommends a host architecture and provides the state machines that would guide operations. Example function implementations for a theoretical compliant host are provided in this chapter. Common

advanced requirements (such as multiple cards per slot) and optimizations (such as DMA) are possible. No attempt has been made, however, to accommodate non-storage devices that are accessed on a SD/MMC cardmode, including SDIO devices.

The core operation being abstracted is the command/response sequence for high-level card transactions. The key functions, `CmdStart()`, `CmdWaitEnd()`, `CmdDataRd()` and `CmdDataWr()`, are called within the state machine of Figure C-2. If return error from one of the functions will abort the state machine, so the requisite considerations, such as preparing for the next command or preventing further interrupts, must be handled if an operation cannot be completed.

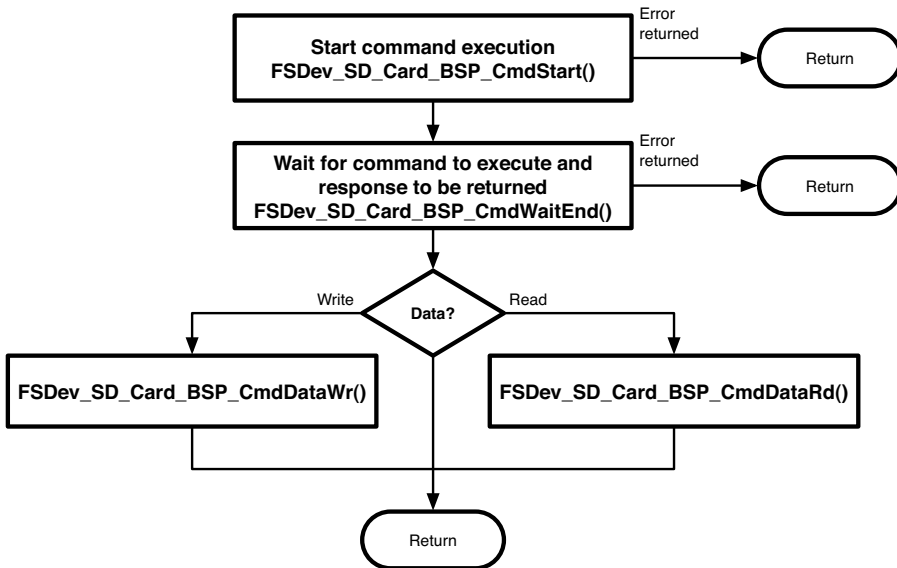

Figure C-2 **Command execution**

The remaining functions either investigate host capabilities (`GetBlkCntMax()`, `GetBusWidthMax()`) or set operational parameters (`SetBusWidth()`, `SetClkFreq()`, `SetTimeoutData()`, `SetTimeoutResp()`). Together, these function sets help configure a new card upon insertion. Note that the parameters configured by the 'set' functions belong to the card, not the slot; if multiple cards may be multiplexed in a single slot, these must be saved when set and restored whenever `Lock()` is called.

Two elements of host behavior routinely influence implementation and require design choices. First, block data can typically be read/written either directly from a FIFO or transferred automatically by the peripheral to/from a memory buffer with DMA. While the former approach may be simpler—no DMA controller need be setup—it may not be reliable. Unless the host can stop the host clock upon FIFO underrun (for write) or overrun (for read), effectively pausing the operation from the card's perspective, transfers at high clock frequency or multiple-bus configurations will probably fail. Interrupts or other tasks can interrupt the operation, or the CPU just may be unable to fill the FIFO fast enough. DMA avoids those pitfalls by offloading the responsibility for moving data directly to the CPU.

Second, the completion of operations such as command execution and data read/write are often signaled via interrupts (unless some error occurs, whereupon a different interrupt is triggered). During large transfers, these operations occur frequently and the typical wait between initiation and completion is measured in microseconds. On most platforms, polling the interrupt status register within the task performs better (i.e., results in faster reads and writes) than waiting on a semaphore for an asynchronous notification from the ISR, because the penalty of extra context switches is not incurred.

C-5-1 FSDev_SD_Card_BSP_Open()

CPU_BOOLEAN FSDev_SD_Card_BSP_Open (FS_QTY unit_nbr);

File	Called from	Code enabled by
fs_dev_sd_card_bsp.c	FSDev_SD_Card_Refresh()	N/A

Open (initialize) SD/MMC card interface.

ARGUMENTS

unit_nbr Unit number of SD/MMC card.

RETURNED VALUE

DEF_OK, if interface was opened.

DEF_FAIL, otherwise.

NOTES/WARNINGS

This function will be called EVERY time the device is opened.

C-5-2 FSDev_SD_Card_BSP_Lock/Unlock()

```
void FSDev_SD_Card_BSP_Lock (FS_QTY unit_nbr);
void FSDev_SD_Card_BSP_Unlock (FS_QTY unit_nbr);
```

File	Called from	Code enabled by
fs_dev_sd_card_bsp.c	SD/MMC cardmode driver	N/A

Acquire/release SD/MMC card bus lock.

ARGUMENTS

unit_nbr Unit number of SD/MMC card.

RETURNED VALUE

None.

NOTES/WARNINGS

`FSDev_SD_Card_BSP_Lock()` will be called before the driver begins to access the SD/MMC card bus. The application should NOT use the same bus to access another device until the matching call to `FSDev_SD_Card_BSP_Unlock()` has been made.

The clock frequency, bus width and timeouts set by the `FSDev_SD_Card_BSP_Set####()` functions are parameters of the card, not the bus. If multiple cards are located on the same bus, those parameters must be saved (in memory) when set and restored when `FSDev_SD_Card_BSP_Lock()` is called.

C-5-3 FSDev_SD_Card_BSP_CmdStart()

```
void FSDev_SD_Card_BSP_CmdStart (FS_QTY          unit_nbr,  
                                FS_DEV_SD_CARD_CMD *p_cmd,  
                                void              *p_data,  
                                FS_DEV_SD_CARD_ERR *p_err);
```

File	Called from	Code enabled by
fs_dev_sd_card_bsp.c	SD/MMC cardmode driver	N/A

Start a command.

ARGUMENTS

unit_nbr Unit number of SD/MMC card.

p_cmd Pointer to command to transmit (see Note #2).

p_data Pointer to buffer address for DMA transfer (see Note #3).

p_err Pointer to variable that will receive the return error code from this function:

FS_DEV_SD_CARD_ERR_NONE	No error.
FS_DEV_SD_CARD_ERR_NO_CARD	No card present.
FS_DEV_SD_CARD_ERR_BUSY	Controller is busy.
FS_DEV_SD_CARD_ERR_UNKNOWN	Unknown or other error.

RETURNED VALUE

None.

NOTES/WARNINGS

- 1 The command start will be followed by zero, one or two additional BSP function calls, depending on whether data should be transferred and on whether any errors occur.
 - a. **FSDev_SD_Card_BSP_CmdStart()** starts execution of the command. IT may also set up the DMA transfer (if necessary).

b. `FSDev_SD_Card_BSP_CmdWaitEnd()` waits for the execution of the command to end, getting the command response (if any).

c. If data should be transferred from the card to the host, `FSDev_SD_Card_BSP_CmdDataRd()` will read that data; if data should be transferred from the host to the card, `FSDev_SD_Card_BSP_CmdDataWr()` will write that data.

2 The command `p_cmd` has the following parameters:

- `p_cmd->Cmd` is the command index.
- `p_cmd->Arg` is the 32-bit argument (or 0 if there is no argument).
- `p_cmd->Flags` is a bit-mapped variable with zero or more command flags:

<code>FS_DEV_SD_CARD_CMD_FLAG_INIT</code>	Initialization sequence before command.
<code>FS_DEV_SD_CARD_CMD_FLAG_BUSY</code>	Busy signal expected after command.
<code>FS_DEV_SD_CARD_CMD_FLAG_CRC_VALID</code>	CRC valid after command.
<code>FS_DEV_SD_CARD_CMD_FLAG_IX_VALID</code>	Index valid after command.
<code>FS_DEV_SD_CARD_CMD_FLAG_OPEN_DRAIN</code>	Command line is open drain.
<code>FS_DEV_SD_CARD_CMD_FLAG_DATA_START</code>	Data start command.
<code>FS_DEV_SD_CARD_CMD_FLAG_DATA_STOP</code>	Data stop command.
<code>FS_DEV_SD_CARD_CMD_FLAG_RESP</code>	Response expected.
<code>FS_DEV_SD_CARD_CMD_FLAG_RESP_LONG</code>	Long response expected.

- `p_cmd->DataDir` indicates the direction of any data transfer that should follow this command, if any:

<code>FS_DEV_SD_CARD_DATA_DIR_NONE</code>	No data transfer.
<code>FS_DEV_SD_CARD_DATA_DIR_HOST_TO_CARD</code>	Transfer host-to-card (write).
<code>FS_DEV_SD_CARD_DATA_DIR_CARD_TO_HOST</code>	Transfer card-to-host (read).

- `p_cmd->DataType` indicates the type of the data transfer that should follow this command, if any:

<code>FS_DEV_SD_CARD_DATA_TYPE_NONE</code>	No data transfer.
<code>FS_DEV_SD_CARD_DATA_TYPE_SINGLE_BLOCK</code>	Single data block.
<code>FS_DEV_SD_CARD_DATA_TYPE_MULTI_BLOCK</code>	Multiple data blocks.
<code>FS_DEV_SD_CARD_DATA_TYPE_STREAM</code>	Stream data.

- `p_cmd->RespType` indicates the type of the response that should be expected from this command:

<code>FS_DEV_SD_CARD_RESP_TYPE_NONE</code>	No response.
<code>FS_DEV_SD_CARD_RESP_TYPE_R1</code>	R1 response: Normal Response Command.
<code>FS_DEV_SD_CARD_RESP_TYPE_R1B</code>	R1b response.
<code>FS_DEV_SD_CARD_RESP_TYPE_R2</code>	R2 response: CID, CSD Register.
<code>FS_DEV_SD_CARD_RESP_TYPE_R3</code>	R3 response: OCR Register.
<code>FS_DEV_SD_CARD_RESP_TYPE_R4</code>	R4 response: Fast I/O Response (MMC).
<code>FS_DEV_SD_CARD_RESP_TYPE_R5</code>	R5 response: Interrupt Request Response (MMC).
<code>FS_DEV_SD_CARD_RESP_TYPE_R5B</code>	R5B response.
<code>FS_DEV_SD_CARD_RESP_TYPE_R6</code>	R6 response: Published RCA Response.
<code>FS_DEV_SD_CARD_RESP_TYPE_R7</code>	R7 response: Card Interface Condition.

- `p_cmd->BlkSize` and `p_cmd->BlkCnt` are the block size and block count of the data transfer that should follow this command, if any.
- 3 The pointer to the data buffer that will receive the data transfer that should follow this command, `p_data`, is given so that a DMA transfer can be set up.

EXAMPLE

The example implementation of `FSDev_SD_Card_BSP_CmdStart()` in , like the examples in subsequent sections, targets a generic host conformant to the SD card association's host controller specification. While few hosts do conform, most have a similar mixture of registers and registers fields and require the same sequences of basic actions.

```
void FSDev_SD_Card_BSP_CmdStart (FS_QTY          unit_nbr,
                                FS_DEV_SD_CARD_CMD *p_cmd,
                                void              *p_data,
                                FS_DEV_SD_CARD_ERR *p_err)
{
    CPU_INT16U  command;
    CPU_INT32U  present_state;
    CPU_INT16U  transfer_mode;
    present_state = REG_STATE;                /* Chk if controller busy. */ (1)
    if (DEF_BIT_IS_SET_ANY(present_state, BIT_STATE_CMD_INHIBIT_DAT |
                           BIT_STATE_CMD_INHIBIT_CMD) == DEF_YES) {
        *p_err = FS_DEV_SD_CARD_ERR_BUSY;
        return;
    }
    transfer_mode = DEF_BIT_NONE;             /* Calc transfer mode reg value. */ (2)
    if (p_cmd->DataType == FS_DEV_SD_CARD_DATA_TYPE_MULTIPLE_BLOCK) {
        transfer_mode |= BIT_TRANSFER_MODE_MULTIPLE_BLOCK
                        | BIT_TRANSFER_MODE_AUTO_CMD12
                        | BIT_TRANSFER_MODE_BLOCK_COUNT_ENABLE;
    }
    if (p_cmd->DataDir == FS_DEV_SD_CARD_DATA_DIR_CARD_TO_HOST) {
        transfer_mode |= BIT_TRANSFER_MODE_READ | BIT_TRANSFER_MODE_DMA_ENABLE;
    } else {
        transfer_mode |= BIT_TRANSFER_MODE_DMA_ENABLE;
    }
    command = (CPU_INT16U)p_cmd->Cmd << 8;   /* Calc command register value */ (3)
    if (DEF_BIT_IS_SET(p_cmd->Flags, FS_DEV_SD_CARD_CMD_FLAG_DATA_START) == DEF_YES) {
        command |= BIT_COMMAND_DATA_PRESENT;
    }
    if (DEF_BIT_IS_SET(p_cmd->Flags, FS_DEV_SD_CARD_CMD_FLAG_IX_VALID) == DEF_YES) {
        command |= BIT_COMMAND_DATA_COMMAND_IX_CHECK;
    }
    if (DEF_BIT_IS_SET(p_cmd->Flags, FS_DEV_SD_CARD_CMD_FLAG_CRC_VALID) == DEF_YES) {
        command |= BIT_COMMAND_DATA_COMMAND_CRC_CHECK;
    }
    if (DEF_BIT_IS_SET(p_cmd->Flags, FS_DEV_SD_CARD_CMD_FLAG_RESP) == DEF_YES) {
        if (DEF_BIT_IS_SET(p_cmd->Flags, FS_DEV_SD_CARD_CMD_FLAG_RESP_LONG) == DEF_YES) {
            command |= BIT_COMMAND_DATA_COMMAND_RESPONSE_LENGTH_136;
        } else {
            if (DEF_BIT_IS_SET(p_cmd->Flags, FS_DEV_SD_CARD_CMD_FLAG_BUSY) == DEF_YES) {
                command |= BIT_COMMAND_DATA_COMMAND_RESPONSE_LENGTH_48;
            } else {
                command |= BIT_COMMAND_DATA_COMMAND_RESPONSE_LENGTH_48_BUSY;
            }
        }
    }
}
```

```

                                                                    /* Write registers to exec cmd. */ (4)
REG_SDMA_ADDRESS = p_data;
REG_BLOCK_COUNT  = p_cmd->BlkCnt;
REG_BLOCK_SIZE   = p_cmd->BlkSize;
REG_ARGUMENT     = p_cmd->Arg;
REG_TRANSFER_MODE = transfer_mode;
REG_COMMAND      = command;
*p_err = FS_DEV_SD_CARD_ERR_NONE;
}

```

Listing C-7 **FSDev_SD_Card_BSP_CmdStart()**

- LC-7(1) Check whether the controller is busy. Though no successful operation should return without the controller idle, an error condition, programming mistake or unexpected condition could make an assumption about initial controller state false. This simple validation is recommended to avoid side-effects and to aid port debugging.

- LC-7(2) Calculate the transfer mode register value. The command's `DataType` and `DataDir` members specify the type and direction of any transfer. Since this examples uses DMA, DMA is enabled in the transfer mode register.

- LC-7(3) Calculate the command register value. The command index is available in the command's `Cmd` member, which is supplemented by the bits OR'd into `Flags` to describe the expected result—response and data transfer—following the command execution.

- LC-7(4) The hardware registers are written to execute the command. The sequence in which the registers are written is important. Typically, as in this example, the assignment to the command register actually triggers execution.

C-5-4 FSDev_SD_Card_BSP_CmdWaitEnd()

```
void FSDev_SD_Card_BSP_CmdWaitEnd (FS_QTY          unit_nbr,
                                   FS_DEV_SD_CARD_CMD *p_cmd,
                                   CPU_INT32U         *p_resp,
                                   FS_DEV_SD_CARD_ERR  *p_err);
```

File	Called from	Code enabled by
fs_dev_sd_card_bsp.c	SD/MMC cardmode driver	N/A

Wait for command to end and get command response.

ARGUMENTS

unit_nbr Unit number of SD/MMC card.

p_cmd Pointer to command that is ending.

p_resp Pointer to buffer that will receive command response, if any.

p_err Pointer to variable that will receive the return error code from this function:

FS_DEV_SD_CARD_ERR_NONE	No error.
FS_DEV_SD_CARD_ERR_NO_CARD	No card present.
FS_DEV_SD_CARD_ERR_UNKNOWN	Unknown or other error.
FS_DEV_SD_CARD_ERR_WAIT_TIMEOUT	Timeout in waiting for command response.
FS_DEV_SD_CARD_ERR_RESP_TIMEOUT	Timeout in receiving command response.
FS_DEV_SD_CARD_ERR_RESP_CHKSUM	Error in response checksum.
FS_DEV_SD_CARD_ERR_RESP_CMD_IX	Response command index error.
FS_DEV_SD_CARD_ERR_RESP_END_BIT	Response end bit error.
FS_DEV_SD_CARD_ERR_RESP	Other response error.
FS_DEV_SD_CARD_ERR_DATA	Other data error.

RETURNED VALUE

None.

NOTES/WARNINGS

- 1 This function will be called even if no response is expected from the command.
- 2 This function will *not* be called if `FSDev_SD_Card_BSP_CmdStart()` returned an error.
- 3 The data stored in the response buffer should include only the response data, i.e., should not include the start bit, transmission bit, command index, CRC and end bit.
 - For a command with a normal (48-bit) response, a 4-byte response should be stored in `p_resp`.
 - For a command with a long (136-bit) response, a 16-byte response should be returned in `p_resp`:

The first 4-byte word should hold bits 127..96 of the response.

The second 4-byte word should hold bits 95..64 of the response.

The third 4-byte word should hold bits 63..32 of the response.

The four 4-byte word should hold bits 31.. 0 of the response.

EXAMPLE

The implementation of `FSDev_SD_Card_BSP_CmdWaitEnd()` in is targeted for the same host controller as the other listings in this chapter; for more information, see `FSDev_SD_Card_BSP_CmdStart()`.

```
void FSDev_SD_Card_BSP_CmdWaitEnd (FS_QTY          unit_nbr,
                                   FS_DEV_SD_CARD_CMD *p_cmd,
                                   CPU_INT32U        *p_resp,
                                   FS_DEV_SD_CARD_ERR *p_err)
{
    CPU_INT16U  interrupt_status;
    CPU_INT16U  error_status;
    CPU_INT16U  timeout;
    timeout     = 0u;                /* Wait until cmd exec complete.*/ (1)
    interrupt_status = REG_INTERRUPT_STATUS;
    while (DEF_BIT_IS_CLR(interrupt_status, BIT_INTERRUPT_STATUS_ERROR |
                          BIT_INTERRUPT_STATUS_COMMAND_COMPLETE) == DEF_YES) {
        timeout++;
        interrupt_status = REG_INTERRUPT_STATUS;
        if (timeout == TIMEOUT_RESP_MAX) {
            *p_err = FS_DEV_SD_CARD_ERR_WAIT_TIMEOUT;
            return;
        }
    }
    /* Handle error. */ (2)
    if (DEF_BIT_IS_SET(interrupt_status, BIT_INTERRUPT_STATUS_ERROR) == DEF_YES) {
        error_status = REG_ERROR_STATUS;
        if (DEF_BIT_IS_SET(error_status, REG_ERROR_STATUS_COMMAND_INDEX) == DEF_YES) {
            *p_err = FS_DEV_SD_CARD_ERR_RESP_CMD_IX;
        } else if (DEF_BIT_IS_SET(error_status, REG_ERROR_STATUS_COMMAND_END_BIT) == DEF_YES) {
            *p_err = FS_DEV_SD_CARD_ERR_RESP_END_BIT;
        } else if (DEF_BIT_IS_SET(error_status, REG_ERROR_STATUS_COMMAND_CRC) == DEF_YES) {
            *p_err = FS_DEV_SD_CARD_ERR_RESP_CRC;
        } else if (DEF_BIT_IS_SET(error_status, REG_ERROR_STATUS_COMMAND_TIMEOUT) == DEF_YES) {
            *p_err = FS_DEV_SD_CARD_ERR_RESP_TIMEOUT;
        } else {
            *p_err = FS_DEV_SD_CARD_ERR_RESP;
        }
        REG_ERROR_STATUS = error_status;
        REG_INTERRUPT_STATUS = interrupt_status;
        return;
    }
}
```

```

                                                    /* Read response.          */ (3)
REG_INTERRUPT_STATUS = BIT_INTERRUPT_STATUS_COMMAND_COMPLETE;
if (DEF_BIT_IS_SET(p_cmd->Flags, FS_DEV_SD_CARD_CMD_FLAG_RESP) == DEF_YES) {
    if (DEF_BIT_IS_SET(p_cmd->Flags, FS_DEV_SD_CARD_CMD_FLAG_RESP_LONG) == DEF_YES) {
        *(p_resp + 3) = REG_RESPONSE_00
        *(p_resp + 2) = REG_RESPONSE_01
        *(p_resp + 1) = REG_RESPONSE_02
        *(p_resp + 0) = REG_RESPONSE_03
    } else {
        *(p_resp + 0) = REG_RESPONSE_00
    }
}
}

*p_err = FS_DEV_SD_CARD_ERR_NONE;
}

```

Listing C-8 **FSDev_SD_Card_BSP_CmdWaitEnd()**

- LC-8(1) Wait until command execution completes or an error occurs. The wait loop (or wait on semaphore) *should* always have a timeout to avoid blocking the task in the case of an unforeseen hardware malfunction or a software flaw.

- LC-8(2) Check if an error occurred. The error status register is decoded to produce the actual error condition. That is not necessary, strictly, but error counters that accumulate within the generic driver based upon returned error values may be useful while debugging a port.

- LC-8(3) Read the response, if any. Note that the order in which a long response is stored in the buffer may oppose its storage in the controller's register or FIFO.

C-5-5 FSDev_SD_Card_BSP_CmdDataRd()

```
void FSDev_SD_Card_BSP_CmdDataRd (FS_QTY          unit_nbr,
                                   FS_DEV_SD_CARD_CMD *p_cmd,
                                   void              *p_dest,
                                   FS_DEV_SD_CARD_ERR *p_err);
```

File	Called from	Code enabled by
fs_dev_sd_card_bsp.c	FSDev_SD_Card_RdData()	N/A

Read data following a command.

ARGUMENTS

- unit_nbr** Unit number of SD/MMC card.
- p_cmd** Pointer to command that was started.
- p_dest** Pointer to destination buffer.
- p_err** Pointer to variable that will receive the return error code from this function:
- FS_DEV_SD_CARD_ERR_NONE No error.
 - FS_DEV_SD_CARD_ERR_NO_CARD No card present.
 - FS_DEV_SD_CARD_ERR_UNKNOWN Unknown or other error.
 - FS_DEV_SD_CARD_ERR_WAIT_TIMEOUT Timeout in waiting for data.
 - FS_DEV_SD_CARD_ERR_DATA_OVERRUN Data overrun.
 - FS_DEV_SD_CARD_ERR_DATA_TIMEOUT Timeout in receiving data.
 - FS_DEV_SD_CARD_ERR_DATA_CHKSUM Error in data checksum.
 - FS_DEV_SD_CARD_ERR_DATA_START_BIT Data start bit error.
 - FS_DEV_SD_CARD_ERR_DATA Other data error.

RETURNED VALUE

None.

NOTES/WARNINGS

None.

EXAMPLE

The implementation of `FSDev_SD_Card_BSP_CmdDataRd()` in Listing C-9 is targeted for the same host controller as the other listings in this chapter; for more information, see `FSDev_SD_Card_BSP_CmdStart()`.

```
void FSDev_SD_Card_BSP_CmdDataRd (FS_QTY          unit_nbr,
                                  FS_DEV_SD_CARD_CMD *p_cmd,
                                  void              *p_dest,
                                  FS_DEV_SD_CARD_ERR *p_err)
{
    CPU_INT16U  interrupt_status;
    CPU_INT16U  error_status;
    CPU_INT16U  timeout;
    timeout      = 0u;                /* Wait until data xfer compl. */ (1)
    interrupt_status = REG_INTERRUPT_STATUS;
    while (DEF_BIT_IS_CLR(interrupt_status,BIT_INTERRUPT_STATUS_ERROR |
                          BIT_INTERRUPT_STATUS_TRANSFER_COMPLETE) == DEF_YES) {
        timeout++;
        interrupt_status = REG_INTERRUPT_STATUS;
        if (timeout == TIMEOUT_TRANSFER_MAX) {
            *p_err = FS_DEV_SD_CARD_ERR_WAIT_TIMEOUT;
            return;
        }
    }
    /* Handle error. */ (2)
    if (DEF_BIT_IS_SET(interrupt_status, BIT_INTERRUPT_STATUS_ERROR) == DEF_YES) {
        error_status = REG_ERROR_STATUS;
        if (DEF_BIT_IS_SET(error_status, REG_ERROR_STATUS_DATA_END_BIT) == DEF_YES) {
            *p_err = FS_DEV_SD_CARD_ERR_DATA;
        } else if (DEF_BIT_IS_SET(error_status, REG_ERROR_STATUS_DATA_CRC) == DEF_YES) {
            *p_err = FS_DEV_SD_CARD_ERR_DATA_CRC;
        } else if (DEF_BIT_IS_SET(error_status, REG_ERROR_STATUS_DATA_TIMEOUT) == DEF_YES) {
            *p_err = FS_DEV_SD_CARD_ERR_DATA_TIMEOUT;
        } else {
            *p_err = FS_DEV_SD_CARD_ERR_UNKONWN;
        }
        REG_ERROR_STATUS      = error_status;
        REG_INTERRUPT_STATUS = interrupt_status;
        return;
    }
    *p_err = FS_DEV_SD_CARD_ERR_NONE; (3)
}
```

Listing C-9 `FSDev_SD_Card_BSP_CmdDataRd()`

- LC-9(1) Wait until data transfer completes or an error occurs. The wait loop (or wait on semaphore) *should* always have a timeout to avoid blocking the task in the case of an unforeseen hardware malfunction or a software flaw.
- LC-9(2) Check if an error occurred. The error status register is decoded to produce the actual error condition. That is not necessary, strictly, but error counters that accumulate within the generic driver based upon returned error values may be useful while debugging a port.
- LC-9(3) Return no error. The data has been transferred already to the memory buffer using DMA.

C-5-6 FSDev_SD_Card_BSP_CmdDataWr()

```
void FSDev_SD_Card_BSP_CmdDataWr (FS_QTY          unit_nbr,  
                                   FS_DEV_SD_CARD_CMD *p_cmd,  
                                   void              *p_src,  
                                   FS_DEV_SD_CARD_ERR *p_err);
```

File	Called from	Code enabled by
fs_dev_sd_card_bsp.c	FSDev_SD_Card_WrData()	N/A

Write data following a command.

ARGUMENTS

<code>unit_nbr</code>	Unit number of SD/MMC card.
<code>p_cmd</code>	Pointer to command that was started.
<code>p_src</code>	Pointer to source buffer.
<code>p_err</code>	Pointer to variable that will receive the return error code from this function: <code>FS_DEV_SD_CARD_ERR_NONE</code> No error. <code>FS_DEV_SD_CARD_ERR_NO_CARD</code> No card present. <code>FS_DEV_SD_CARD_ERR_UNKNOWN</code> Unknown or other error. <code>FS_DEV_SD_CARD_ERR_WAIT_TIMEOUT</code> Timeout in waiting for data. <code>FS_DEV_SD_CARD_ERR_DATA_UNDERRUN</code> Data underrun. <code>FS_DEV_SD_CARD_ERR_DATA_CHKSUM</code> Error in data checksum. <code>FS_DEV_SD_CARD_ERR_DATA_START_BIT</code> Data start bit error. <code>FS_DEV_SD_CARD_ERR_DATA</code> Other data error.

RETURNED VALUE

None.

NOTES/WARNINGS

None.

EXAMPLE

The implementation of `FSDev_SD_Card_BSP_CmdDataWr()` in Listing C-10 is targeted for the same host controller as the other listings in this chapter; for more information, see `FSDev_SD_Card_BSP_CmdStart()`.

```

void FSDev_SD_Card_BSP_CmdDataWr (FS_QTY          unit_nbr,
                                  FS_DEV_SD_CARD_CMD *p_cmd,
                                  void              *p_src,
                                  FS_DEV_SD_CARD_ERR *p_err)
{
    CPU_INT16U  interrupt_status;
    CPU_INT16U  error_status;
    CPU_INT16U  timeout;
    timeout     = 0u;                /* Wait until data xfer compl. */ (1)
    interrupt_status = REG_INTERRUPT_STATUS;
    while (DEF_BIT_IS_CLR(interrupt_status,BIT_INTERRUPT_STATUS_ERROR |
                          BIT_INTERRUPT_STATUS_TRANSFER_COMPLETE) == DEF_YES) {
        timeout++;
        interrupt_status = REG_INTERRUPT_STATUS;
        if (timeout == TIMEOUT_TRANSFER_MAX) {
            *p_err = FS_DEV_SD_CARD_ERR_WAIT_TIMEOUT;
            return;
        }
    }
    /* Handle error. */ (2)
    if (DEF_BIT_IS_SET(interrupt_status, BIT_INTERRUPT_STATUS_ERROR) == DEF_YES) {
        error_status = REG_ERROR_STATUS;
        if (DEF_BIT_IS_SET(error_status, REG_ERROR_STATUS_DATA_END_BIT) == DEF_YES) {
            *p_err = FS_DEV_SD_CARD_ERR_DATA;
        } else if (DEF_BIT_IS_SET(error_status, REG_ERROR_STATUS_DATA_CRC) == DEF_YES) {
            *p_err = FS_DEV_SD_CARD_ERR_DATA_CRC;
        } else if (DEF_BIT_IS_SET(error_status, REG_ERROR_STATUS_DATA_TIMEOUT) == DEF_YES) {
            *p_err = FS_DEV_SD_CARD_ERR_DATA_TIMEOUT;
        } else {
            *p_err = FS_DEV_SD_CARD_ERR_UNKONWN;
        }
    }
    REG_ERROR_STATUS      = error_status;
    REG_INTERRUPT_STATUS = interrupt_status;
    return;
}

*p_err = FS_DEV_SD_CARD_ERR_NONE; (3)
}

```

Listing C-10 `FSDev_SD_Card_BSP_CmdDataWr()`

-
- LC-10(1) Wait until data transfer completes or an error occurs. The wait loop (or wait on semaphore) SHOULD always have a timeout to avoid blocking the task in the case of an unforeseen hardware malfunction or a software flaw.
- LC-10(2) Check if an error occurred. The error status register is decoded to produce the actual error condition. That is not necessary, strictly, but error counters that accumulate within the generic driver based upon returned error values may be useful while debugging a port.
- LC-10(3) Return no error. The data has been transferred already from the memory buffer using DMA.

C-5-7 FSDev_SD_Card_BSP_GetBlkCntMax()

```
CPU_INT32U FSDev_SD_Card_BSP_GetBlkCntMax (FS_QTY      unit_nbr,
                                             CPU_INT32U blk_size);
```

File	Called from	Code enabled by
fs_dev_sd_card_bsp.c	FSDev_SD_Card_Refresh()	N/A

Get maximum number of blocks that can be transferred with a multiple read or multiple write command.

ARGUMENTS

unit_nbr Unit number of SD/MMC card.

blk_size Block size, in octets.

RETURNED VALUE

Maximum number of blocks.

NOTES/WARNINGS

- 1 The DMA region from which data is read or written may be a limited size. The count returned by this function should be the maximum number of blocks of size **blk_size** that can fit into this region.
- 2 If the controller is not capable of multiple block reads or writes, 1 should be returned.
- 3 If the controller has no limit on the number of blocks in a multiple block read or write, **DEF_INT_32U_MAX_VAL** should be returned.
- 4 This function SHOULD always return the same value. If hardware constraints change at run-time, the device MUST be closed and re-opened for any changes to be effective.

C-5-8 FSDev_SD_Card_BSP_GetBusWidthMax()

```
CPU_INT08U FSDev_SD_Card_BSP_GetBusWidthMax (FS_QTY unit_nbr);
```

File	Called from	Code enabled by
fs_dev_sd_card_bsp.c	FSDev_SD_Card_Refresh()	N/A

Get maximum bus width, in bits.

ARGUMENTS

`unit_nbr` Unit number of SD/MMC card.

RETURNED VALUE

Maximum bus width.

NOTES/WARNINGS

- 1 Legal values are typically 1, 4 and 8.
- 2 This function *should* always return the same value. If hardware constraints change at run-time, the device *must* be closed and re-opened for any changes to be effective.

C-5-9 FSDev_SD_Card_BSP_SetBusWidth()

```
void FSDev_SD_Card_BSP_SetBusWidth (FS_QTY      unit_nbr,  
                                     CPU_INT08U width);
```

File	Called from	Code enabled by
fs_dev_sd_card_bsp.c	FSDev_SD_Card_Refresh(), FSDev_SD_Card_SetBusWidth()	N/A

Set bus width.

ARGUMENTS

unit_nbr Unit number of SD/MMC card.

width Bus width, in bits.

RETURNED VALUE

None.

NOTES/WARNINGS

None.

EXAMPLE

The implementation of `FSDev_SD_Card_BSP_SetBusWidth()` in Listing C-11 is targeted for the same host controller as the other listings in this chapter; for more information, see `FSDev_SD_Card_BSP_CmdStart()`.

```
void FSDev_SD_Card_BSP_SetBusWidth (FS_QTY    unit_nbr,
                                     CPU_INT08U width)
{
    if (width == 1u) {
        REG_HOST_CONTROL &= ~BIT_HOST_CONTROL_DATA_TRANSFER_WIDTH;
    } else {
        REG_HOST_CONTROL |= BIT_HOST_CONTROL_DATA_TRANSFER_WIDTH;
    }
}
```

Listing C-11 `FSDev_SD_Card_BSP_SetBusWidth()`

C-5-10 FSDev_SD_Card_BSP_SetClkFreq()

```
void FSDev_SD_Card_BSP_SetClkFreq (FS_QTY      unit_nbr,  
                                   CPU_INT32U  freq);
```

File	Called from	Code enabled by
fs_dev_sd_card_bsp.c	FSDev_SD_Card_Refresh()	N/A

Set clock frequency.

ARGUMENTS

unit_nbr Unit number of SD/MMC card.

freq Clock frequency, in Hz.

RETURNED VALUE

None.

NOTES/WARNINGS

The effective clock frequency **MUST** be no more than **freq**. If the frequency cannot be configured equal to **freq**, it should be configured less than **freq**.

C-5-11 FSDev_SD_Card_BSP_SetTimeoutData()

```
void FSDev_SD_Card_BSP_SetTimeoutData (FS_QTY      unit_nbr,  
                                       CPU_INT32U  to_clks);
```

File	Called from	Code enabled by
fs_dev_sd_card_bsp.c	FSDev_SD_Card_Refresh()	N/A

Set data timeout.

ARGUMENTS

unit_nbr Unit number of SD/MMC card.

to_clks Timeout, in clocks.

RETURNED VALUE

None.

NOTES/WARNINGS

None.

C-5-12 FSDev_SD_Card_BSP_SetTimeoutResp()

```
void FSDev_SD_Card_BSP_SetTimeoutResp (FS_QTY      unit_nbr,  
                                       CPU_INT32U  to_ms);
```

File	Called from	Code enabled by
fs_dev_sd_card_bsp.c	FSDev_SD_Card_Refresh()	N/A

Set data timeout.

ARGUMENTS

unit_nbr Unit number of SD/MMC card.

to_ms Timeout, in milliseconds.

RETURNED VALUE

None.

NOTES/WARNINGS

None.

C-6 SD/MMC SPI MODE BSP

SD/MMC card can also be accessed through an SPI bus (also described as the one-wire mode). Please refer to section C-7 “SPI BSP” on page 453 for the details on how to implement the software port for your SPI bus.

C-7 SPI BSP

Among the most common—and simplest—serial interfaces supported by built-in CPU peripherals is Serial Peripheral Interface (SPI). Four hardware signals connect a defined master (or host) to each slave (or device): a slave select, a clock, a slave input and a slave output. Three of these, all except the slave select, may be shared among all slaves, though hosts often have several SPI controllers to simplify integration and allow simultaneous access to multiple slaves. Serial flash, serial EEPROM and SD/MMC cards are among the many devices which use SPI.

Signal	Description
SSEL (CS)	Slave select
SCLK	Clock
SO (MISO)	Slave output (master input)
SI (MOSI)	Slave input (master output)

Table C-3 SPI signals

No specification exists for SPI, a condition which invites technological divergence. So though the simplicity of the interface limits variations between implementations, the required transfer unit length, shift direction, clock frequency and clock polarity and phase do vary from device to device. Take as an example Figure C-3 which gives the bit form of a basic command/response exchange on a typical serial flash. The command and response both divide into 8-bit chunks, the transfer unit for the device. Within these units, the data is transferred from most significant bit (MSB) to least significant bit (LSB), which is the slave's shift direction. Though not evident from the diagram—the horizontal axis being labeled in clocks rather than time—the slave cannot operate at a frequency higher than 20-MHz. Finally, the clock signal prior to slave select activation is low (clock polarity or CPOL is 0), and data is latched on the rising clock edge (clock phase or CPHA is 0). Together, those are the aspects of SPI communication that may need to be configured:

- Transfer unit length. A transfer unit is the underlying unit of commands, responses and data. The most common value is eight bits, though slaves commonly require (and masters commonly support) between 8 and 16 bits.
- Shift direction. Either the MSB or LSB of each transfer unit can be the first transmitted on the data line.

- Clock frequency. Limits are usually imposed upon the frequency of the clock signal. Of all variable SPI communication parameters, only this one is explicitly set by the device driver.
- Clock polarity and phase (CPOL and CPHA). SPI communication takes place in any of four modes, depending on the clock phase and clock polarity settings:
 - If CPOL = 0, the clock is low when inactive.
 - If CPOL = 1, the clock is high when inactive.
 - If CPHA = 0, data is “read” on the leading edge of the clock and “changed” on the following edge.
 - If CPHA = 1, data is “changed” on the leading edge of the clock and “read” on the leading edge.

The most commonly-supported settings are {CPOL, CPHA} = {0, 0} and {1, 1}.

- Slave select polarity. The “active” level of the slave select may be electrically high or low. Low is ubiquitous, high rare.

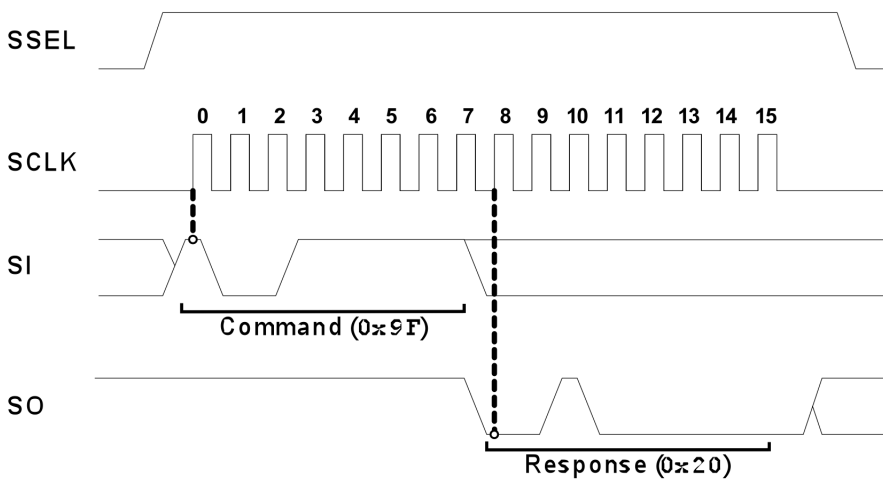

Figure C-3 Example SPI transaction

A BSP is required that abstracts a CPU's SPI peripheral. The port includes one code file named according to the following rubric:

`FS_DEV_<dev_name>_BSP.C` or `FS_DEV_<dev_name>_SPI_BSP.c`

This file is generally placed with other BSP files in a directory named according to the following rubric:

`\Micrium\Software\EvalBoards\<manufacturer>\<board_name>
\<compiler>\BSP\`

Several example ports are included in the μ C/FS distribution in files named according to the following rubric:

`\Micrium\Software\uC-FS\Examples\BSP\Dev\NAND\<manufacturer>\<cpu_name>
\Micrium\Software\uC-FS\Examples\BSP\Dev\NOR\<manufacturer>\<cpu_name>
\Micrium\Software\uC-FS\Examples\BSP\Dev\SD\SPI\<manufacturer>\<cpu_name>`

Check all of these directories for ports for a CPU if porting any SPI device; the CPU may be used with a different type of device, but the port should support another with none or few modifications. Each port must implement the functions to be placed into a `FS_DEV_SPI_API` structure:

```
const FS_DEV_SPI_API FSDev_###_BSP_SPI = {  
    FSDev_BSP_SPI_Open,  
    FSDev_BSP_SPI_Close,  
    FSDev_BSP_SPI_Lock,  
    FSDev_BSP_SPI_Unlock,  
    FSDev_BSP_SPI_Rd,  
    FSDev_BSP_SPI_Wr,  
    FSDev_BSP_SPI_ChipSelEn,  
    FSDev_BSP_SPI_ChipSelDis,  
    FSDev_BSP_SPI_SetClkFreq  
};
```

The functions which must be implemented are listed and described in Table C-4. SPI is no more than a physical interconnect. The protocol of command-response interchange the master follows to control a slave is specified on a per-slave basis. Control of the chip select (SSEL) is separated from the reading and writing of data to the slave because multiple bus

transactions (e.g., a read then a write then another read) are often performed without breaking slave selection. Indeed, some slaves require bus transactions (or “empty” clocks) AFTER the select has been disabled.

Function	Description
Open()	Open (initialize) hardware for SPI.
Close()	Close (uninitialize) hardware for SPI.
Lock()	Acquire SPI bus lock.
Unlock()	Release SPI bus lock.
Rd()	Read from SPI bus.
Wr()	Write to SPI bus.
ChipSelEn()	Enable device chip select.
ChipSelDis()	Disable device chip select
SetClkFreq()	Set SPI clock frequency

Table C-4 **SPI port functions**

The first argument of each of these port functions is the device unit number, an identifier unique to each driver/device type—after all, it is the number in the device name. For example, “sd:0:” and “nor:0:” both have unit number 1. If two SPI devices are located on the same SPI bus, either of two approaches can resolve unit number conflicts:

- Unique unit numbers. All devices on the same bus can use the same SPI BSP if and only if each device has a unique unit number. For example, the SD/MMC card “sd:0:” and serial NOR “nor:1:” require only one BSP.
- Unique SPI BSPs. Devices of different types (e.g., a SD/MMC card and a serial NOR) can have the same unit number if and only if each device uses a separate BSP. For example, the SD/MMC card “sd:0:” and serial “nor:0:” require separate BSPs.

C-7-1 Open()

```
CPU_BOOLEAN FSDev_BSP_SPI_Open (FS_QTY unit_nbr);
```

File	Called from	Code enabled by
fs_dev_<dev_name>_bsp.c	Device driver	N/A

Open (initialize) hardware for SPI.

ARGUMENTS

`unit_nbr` Unit number of device.

RETURNED VALUE

`DEF_OK`, if interface was opened.

`DEF_FAIL`, otherwise.

NOTES/WARNINGS

- 1 This function will be called every time the device is opened.
- 2 Several aspects of SPI communication may need to be configured, including:
 - a. Transfer unit length
 - b. Shift direction
 - c. Clock frequency
 - d. Clock polarity and phase (CPOL and CPHA)
 - e. Slave select polarity

- 3 For a SD/MMC card, the following settings should be used:
 - a. Transfer unit length: 8-bits
 - b. Shift direction: MSB first
 - c. Clock frequency: 400-kHz (initially)
 - d. Clock polarity and phase (CPOL and CPHA): CPOL = 0, CPHA = 0
 - e. Slave select polarity: active low.
- 4 The slave select (SSEL or CS) MUST be configured as a GPIO output; it should not be controlled by the CPU's SPI peripheral. The SPI port's `ChipSelEn()` and `ChipSelDis()` functions manually enable and disable the SSEL.

C-7-2 Close()

```
void FSDev_BSP_SPI_Close (FS_QTY unit_nbr);
```

File	Called from	Code enabled by
fs_dev_<dev_name>_bsp.c	Device driver	N/A

Close (uninitialize) hardware for SPI.

ARGUMENTS

`unit_nbr` Unit number of device.

RETURNED VALUE

None.

NOTES/WARNINGS

This function will be called every time the device is closed.

C-7-3 Lock() / Unlock()

```
void FSDev_BSP_SPI_Lock (FS_QTY unit_nbr);  
void FSDev_BSP_SPI_Unlock (FS_QTY unit_nbr);
```

File	Called from	Code enabled by
fs_dev_<dev_name>_bsp.c	Device driver	N/A

Acquire/release SPI bus lock.

ARGUMENTS

unit_nbr Unit number of device.

RETURNED VALUE

None.

NOTES/WARNINGS

Lock() will be called before the driver begins to access the SPI. The application should NOT use the same bus to access another device until the matching call to **Unlock()** has been made.

The clock frequency set by the **SetClkFreq()** function is a parameter of the device, not the bus. If multiple devices are located on the same bus, those parameters must be saved (in memory) when set and restored by **Lock()**. The same should be done for initialization parameters such as transfer unit size and shift direction that vary from device to device.

C-7-4 Rd()

```
void FSDev_BSP_SPI_Rd (FS_QTY      unit_nbr,  
                      void        *p_dest,  
                      CPU_SIZE_T  cnt);
```

File	Called from	Code enabled by
fs_dev_<dev_name>_bsp.c	Device driver	N/A

Read from SPI bus.

ARGUMENTS

unit_nbr Unit number of device.

p_dest Pointer to destination buffer.

cnt Number of octets to read.

RETURNED VALUE

None.

NOTES/WARNINGS

None.

C-7-5 Wr()

```
void FSDev_BSP_SPI_Wr (FS_QTY      unit_nbr,  
                      void        *p_src,  
                      CPU_SIZE_T  cnt);
```

File	Called from	Code enabled by
fs_dev_<dev_name>_bsp.c	Device driver	N/A

Write to SPI bus.

ARGUMENTS

- unit_nbr** Unit number of device.
- p_src** Pointer to source buffer.
- cnt** Number of octets to write.

RETURNED VALUE

None.

NOTES/WARNINGS

None.

C-7-6 ChipSelEn() /ChipSelDis()

```
void FSDev_BSP_SPI_ChipSelEn (FS_QTY unit_nbr);  
void FSDev_BSP_SPI_ChipSelDis (FS_QTY unit_nbr);
```

File	Called from	Code enabled by
fs_dev_<dev_name>_bsp.c	Device driver	N/A

Enable/disable device chip select.

ARGUMENTS

unit_nbr Unit number of device.

RETURNED VALUE

None.

NOTES/WARNINGS

The chip select is typically “active low”. To enable the device, the chip select pin should be cleared; to disable the device, the chip select pin should be set.

C-7-7 SetClkFreq()

```
void FSDev_BSP_SPI_SetClkFreq (FS_QTY      unit_nbr,
                               CPU_INT32U  freq);
```

File	Called from	Code enabled by
fs_dev_<dev_name>_bsp.c	Device driver	N/A

Set SPI clock frequency.

ARGUMENTS

`unit_nbr` Unit number of device.

RETURNED VALUE

None.

NOTES/WARNINGS

The effective clock frequency *must* be no more than `freq`. If the frequency cannot be configured equal to `freq`, it should be configured less than `freq`.

C-8 NAND FLASH PHYSICAL-LAYER DRIVER

The information about porting the NAND driver to a new platform, through either a controller layer implementation or a generic controller BSP is available in Chapter 13, “NAND Flash Driver” on page 159.

C-9 NOR FLASH PHYSICAL-LAYER DRIVER

The NOR driver is divided into three layers. The topmost layer, the generic driver, requires an intermediate physical-layer driver to effect flash operations like erasing blocks and writing octets. The physical-layer driver includes one code/header file pair named according to the following rubric:

```
FS_DEV_NOR_<device_name>.C
```

FS_DEV_NOR_<device_name>.H

A non-uniform flash—a flash with some blocks of one size and some blocks of another—will require a custom driver adapted from the generic driver for the most similar medium type. Multiple small blocks should be grouped together to form large blocks, effectively making the flash appear uniform to the generic driver. A custom physical-layer driver can also implement advanced program operations unique to a NOR device family.

The physical-layer driver acts via a BSP. The generic drivers for traditional NOR flash require a BSP as described in Appendix C, “NOR Flash BSP” on page 473. The drivers for SPI flash require a SPI BSP as described in Appendix C, “NOR Flash SPI BSP” on page 480.

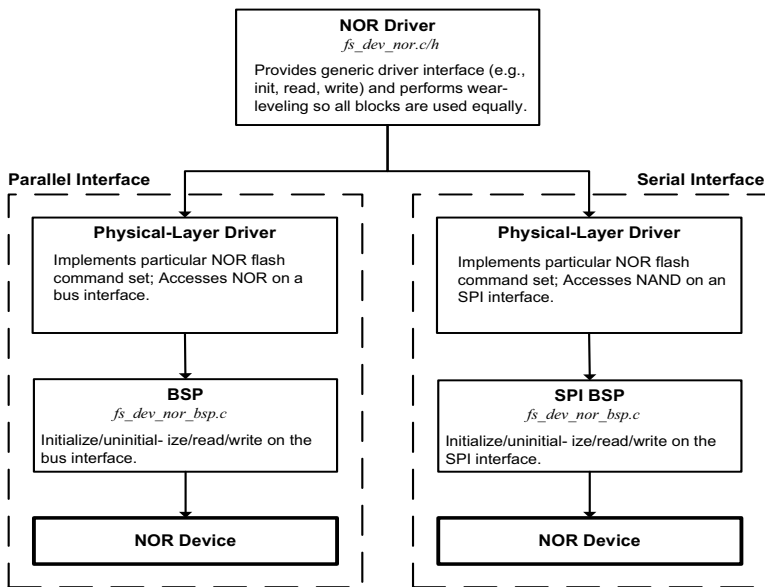

Figure C-4 NOR driver architecture

Each physical-layer driver must implement the functions to be placed into a `FS_DEV_NOR_PHY_API` structure:

```

const FS_DEV_NOR_PHY_API FSDev_NOR_#### {
    FSDev_NOR_PHY_Open,
    FSDev_NOR_PHY_Close,
    FSDev_NOR_PHY_Rd,
    FSDev_NOR_PHY_Wr,
    FSDev_NOR_PHY_EraseBlk,
    FSDev_NOR_PHY_IO_Ctrl,
};

```

The functions which must be implemented are listed and described in Table C-5. The first argument of each of these is a pointer to a `FS_DEV_NOR_PHY_DATA` structure which holds physical device information. Specific members will be described in subsequent sections as necessary. The NOR driver populates an internal instance of this type based upon configuration information. Before the file system suite has been initialized, the application may do the same if raw device accesses are a necessary part of its start-up procedure.

Function	Description
<code>Open()</code>	Open (initialize) a NOR device and get NOR device information.
<code>Close()</code>	Close (uninitialize) a NOR device.
<code>Rd()</code>	Read from a NOR device and store data in buffer.
<code>Wr()</code>	Write to a NOR device from a buffer.
<code>EraseBlk()</code>	Erase block of NOR device.
<code>IO_Ctrl()</code>	Perform NOR device I/O control operation.

Table C-5 NOR flash physical-layer driver functions

C-9-1 Open()

```
void Open (FS_DEV_NOR_PHY_DATA *p_phy_data,  
          FS_ERR *p_err);
```

File	Called from	Code enabled by
NOR physical-layer driver	FSDev_NOR_Open()	N/A

Open (initialize) a NOR device instance and get NOR device information.

ARGUMENTS

p_phy_data Pointer to NOR phy data.

p_err Pointer to variable that will receive the return error code from this function.

RETURNED VALUE

None.

NOTES/WARNINGS

Several members of **p_phy_data** may need to be used/assigned:

- 1 **BlkCnt** and **BlkSize** *must* be assigned the block count and block size of the device, respectively.
- 2 **RegionNbr** specifies the block region that will be used. **AddrRegionStart** *must* be assigned the start address of this block region.
- 3 **DataPtr** may store a pointer to any driver-specific data.
- 4 **UnitNbr** is the unit number of the NOR device.
- 5 **MaxClkFreq** specifies the maximum SPI clock frequency.
- 6 **BusWidth**, **BusWidthMax** and **PhyDevCnt** specify the bus configuration. **AddrBase** specifies the base address of the NOR flash memory.

C-9-2 Close()

```
void Close (FS_DEV_NOR_PHY_DATA *p_phy_data);
```

File	Called from	Code enabled by
NOR physical-layer driver	FSDev_NOR_Close()	N/A

Close (uninitialize) a NOR device instance.

ARGUMENTS

`p_phy_data` Pointer to NOR phy data.

RETURNED VALUE

None.

NOTES/WARNINGS

None.

C-9-3 Rd()

```
void Rd (FS_DEV_NOR_PHY_DATA *p_phy_data,  
         void *p_dest,  
         CPU_INT32U start,  
         CPU_INT32U cnt,  
         FS_ERR *p_err);
```

File	Called from	Code enabled by
NOR physical-layer driver	FSDev_NOR_PhyRdHandler()	N/A

Read from a NOR device and store data in buffer.

ARGUMENTS

p_phy_data Pointer to NOR phy data.

p_dest Pointer to destination buffer.

start Start address of read (relative to start of device).

cnt Number of octets to read.

p_err Pointer to variable that will receive the return error code from this function.

FS_ERR_NONE	Octets read successfully.
FS_ERR_DEV_IO	Device I/O error.
FS_ERR_DEV_TIMEOUT	Device timeout error.

RETURNED VALUE

None.

NOTES/WARNINGS

None.

C-9-4 Wr()

```
void Wr (FS_DEV_NOR_PHY_DATA *p_phy_data,
        void *p_src,
        CPU_INT32U start,
        CPU_INT32U cnt,
        FS_ERR *p_err);
```

File	Called from	Code enabled by
NOR physical-layer driver	FSDev_NOR_PhyWrHandler()	N/A

Write to a NOR device from a buffer.

ARGUMENTS

p_phy_data Pointer to NOR phy data.

p_src Pointer to source buffer.

start Start address of write (relative to start of device).

cnt Number of octets to write.

p_err Pointer to variable that will receive the return error code from this function.

FS_ERR_NONE	Octets written successfully.
FS_ERR_DEV_IO	Device I/O error.
FS_ERR_DEV_TIMEOUT	Device timeout error.

RETURNED VALUE

None.

NOTES/WARNINGS

None.

C-9-5 EraseBlk()

```
void EraseBlk (FS_DEV_NOR_PHY_DATA *p_phy_data,  
              CPU_INT32U           start,  
              CPU_INT32U           size,  
              FS_ERR                *p_err);
```

File	Called from	Code enabled by
NOR physical-layer driver	FSDev_NOR_PhyEraseBlkHandler()	N/A

Erase block of NOR device.

ARGUMENTS

p_phy_data Pointer to NOR phy data.

start Start address of block (relative to start of device).

size Size of block, in octets

p_err Pointer to variable that will receive the return error code from this function.

FS_ERR_NONE	Block erased successfully.
FS_ERR_DEV_INVALID_OP	Invalid operation for device.
FS_ERR_DEV_IO	Device I/O error.
FS_ERR_DEV_TIMEOUT	Device timeout error.

RETURNED VALUE

None.

NOTES/WARNINGS

None.

C-9-6 IO_Ctrl()

```
void IO_Ctrl (FS_DEV_NOR_PHY_DATA *p_phy_data,
             CPU_INT08U          opt,
             void                *p_data,
             FS_ERR              *p_err);
```

File	Called from	Code enabled by
NOR physical-layer driver	various	N/A

Perform NOR device I/O control operation.

ARGUMENTS

p_phy_data Pointer to NOR phy data.

opt Control command.

p_data Buffer which holds data to be used for operation.

OR

Buffer in which data will be stored as a result of operation.

p_err Pointer to variable that will receive the return error code from this function.

FS_ERR_NONE	Control operation performed successfully.
FS_ERR_DEV_INVALID_IO_CTRL I/O	Control unknown to driver.
FS_ERR_DEV_INVALID_OP	Invalid operation for device.
FS_ERR_DEV_IO	Device I/O error.
FS_ERR_DEV_TIMEOUT	Device timeout error.

RETURNED VALUE

None.

NOTES/WARNINGS

None.

C-10 NOR FLASH BSP

A “traditional” NOR flash has two buses, one for addresses and another for data. For example, the host initiates a data read operation with the address of the target location latched onto the address bus; the device responds by outputting a data word on the data bus.

A BSP abstracts the flash interface for the physical layer driver. The port includes one code file:

`FS_DEV_NOR_BSP.C`

This file is generally placed with other BSP files in a directory named according to the following rubric:

```
\Micrium\Software\EvalBoards\<<manufacturer>\<board_name>  
\<compiler>\BSP\
```

Function	Description
<code>FSDev_NOR_BSP_Open()</code>	Open (initialize) bus for NOR
<code>FSDev_NOR_BSP_Close()</code>	Close (uninitialize) bus for NOR.
<code>FSDev_NOR_BSP_Rd_08()/16()</code>	Read from bus interface.
<code>FSDev_NOR_BSP_RdWord_08()/16()</code>	Read word from bus interface.
<code>FSDev_NOR_BSP_WrWord_08()/16()</code>	Write word to bus interface.
<code>FSDev_NOR_BSP_WaitWhileBusy()</code>	Wait while NOR is busy.

Table C-6 NOR BSP functions

C-10-1 FSDev_NOR_BSP_Open()

```
CPU_BOOLEAN FSDev_NOR_BSP_Open (FS_QTY      unit_nbr,
                                CPU_ADDR     addr_base,
                                CPU_INT08U   bus_width,
                                CPU_INT08U   phy_dev_cnt);
```

File	Called from	Code enabled by
fs_dev_nor_bsp.c	NOR physical-layer driver	N/A

Open (initialize) bus for NOR.

ARGUMENTS

`unit_nbr` Unit number of NOR.

`addr_base` Base address of NOR.

`bus_width` Bus width, in bits.

`phy_dev_cnt` Number of devices interleaved.

RETURNED VALUE

`DEF_OK`, if interface was opened.

`DEF_FAIL`, otherwise.

NOTES/WARNINGS

This function will be called *every* time the device is opened.

C-10-2 FSDev_NOR_BSP_Close()

```
void FSDev_NOR_BSP_Close (FS_QTY unit_nbr);
```

File	Called from	Code enabled by
fs_dev_nor_bsp.c	NOR physical-layer driver	N/A

Close (uninitialize) bus for NOR.

ARGUMENTS

`unit_nbr` Unit number of NOR.

RETURNED VALUE

None.

NOTES/WARNINGS

This function will be called *every* time the device is closed.

C-10-3 FSDev_NOR_BSP_Rd_XX()

```
void FSDev_NAND_BSP_Rd_08 (FS_QTY      unit_nbr,
                          void         *p_dest,
                          CPU_ADDR     addr_src,
                          CPU_SIZE_T   cnt);
void FSDev_NAND_BSP_Rd_16 (FS_QTY      unit_nbr,
                          void         *p_dest,
                          CPU_ADDR     addr_src,
                          CPU_SIZE_T   cnt);
```

File	Called from	Code enabled by
fs_dev_nor_bsp.c	NOR physical-layer driver	N/A

Read data from bus interface.

ARGUMENTS

unit_nbr Unit number of NOR.

p_dest Pointer to destination memory buffer.

addr_src Source address.

cnt Number of words to read.

RETURNED VALUE

None.

NOTES/WARNINGS

Data should be read from the bus in words sized to the data bus; for any unit, only the function with its access width will be called.

C-10-4 FSDev_NOR_BSP_RdWord_XX()

```
CPU_INT08U  FSDev_NAND_BSP_RdWord_08 (FS_QTY  unit_nbr,  
                                       CPU_ADDR addr_src);  
CPU_INT16U  FSDev_NAND_BSP_RdWord_16 (FS_QTY  unit_nbr,  
                                       CPU_ADDR addr_src);
```

File	Called from	Code enabled by
fs_dev_nor_bsp.c	NOR physical-layer driver	N/A

Read data from bus interface.

ARGUMENTS

`unit_nbr` Unit number of NOR.

`addr_src` Source address.

RETURNED VALUE

Word read.

NOTES/WARNINGS

Data should be read from the bus in words sized to the data bus; for any unit, only the function with its access width will be called.

C-10-5 FSDev_NOR_BSP_WrWord_XX()

```
void FSDev_NAND_BSP_WrWord_08 (FS_QTY      unit_nbr,
                               CPU_ADDR    addr_src,
                               CPU_INT08U  datum);
void FSDev_NAND_BSP_WrWord_16 (FS_QTY      unit_nbr,
                               CPU_ADDR    addr_src,
                               CPU_INT16U  datum);
```

File	Called from	Code enabled by
fs_dev_nor_bsp.c	NOR physical-layer driver	N/A

Write data to bus interface.

ARGUMENTS

unit_nbr Unit number of NOR.

addr_src Source address.

datum Word to write.

RETURNED VALUE

None.

NOTES/WARNINGS

Data should be written o the bus in words sized to the data bus; for any unit, only the function with its access width will be called.

C-10-6 FSDev_NOR_BSP_WaitWhileBusy()

CPU_BOOLEAN

FSDev_NOR_BSP_WaitWhileBusy

```
(FS_QTY          unit_nbr,  
FS_DEV_NOR_PHY_DATA *p_phy_data,  
CPU_BOOLEAN      (*poll_fnct)(FS_DEV_NOR_PHY_DATA *),  
CPU_INT32U       to_us);
```

File	Called from	Code enabled by
fs_dev_nor_bsp.c	NOR physical-layer driver	N/A

Wait while NAND is busy.

ARGUMENTS

unit_nbr Unit number of NOR.

p_phy_data Pointer to NOR phy data.

poll_fnct Pointer to function to poll, if there is no hardware ready/busy signal.

to_us Timeout, in microseconds.

RETURNED VALUE

DEF_OK, if NAND became ready.

DEF_FAIL, otherwise.

NOTES/WARNINGS

None.

```

CPU_BOOLEAN  FSDev_NOR_BSP_WaitWhileBusy
              (FS_QTY          unit_nbr,
               FS_DEV_NOR_PHY_DATA *p_phy_data,
               CPU_BOOLEAN      (*poll_fnct)(FS_DEV_NOR_PHY_DATA *),
               CPU_INT32U       to_us)
{
    CPU_INT32U  time_cur_us;
    CPU_INT32U  time_start_us;
    CPU_BOOLEAN rdy;
    time_cur_us = /* $$$$ GET CURRENT TIME, IN MICROSECONDS. */;
    time_start_us = time_cur_us;
    while (time_cur_us - time_start_us < to_us) {
        rdy = poll_fnct(p_phy_data);
        if (rdy == DEF_OK) {
            return (DEF_OK);
        }
        time_cur_us = /* $$$$ GET CURRENT TIME, IN MICROSECONDS. */;
    }
    return (DEF_FAIL);
}

```

Listing C-12 **FSDev_NOR_BSP_WaitWhileBusy()** (without hardware read/busy signal)

- LC-12(1) At least `to_us` microseconds should elapse before the function gives up and returns. Returning early can cause disruptive timeout errors within the physical-layer driver.
- LC-12(2) `poll_fnct` should be called with `p_phy_data` as its sole argument. If it returns `DEF_OK`, then the device is ready and the function should return `DEF_OK`.
- LC-12(3) If `to_us` microseconds elapse without the poll function or hardware ready/busy signaling indicating success, the function should return `DEF_FAIL`.

C-11 NOR FLASH SPI BSP

The NOR driver must adapt to the specific hardware using a BSP. A serial NOR Flash will be interfaced on a SPI bus. See Appendix C, “SPI BSP” on page 453 for the details on how to implement the software port for your SPI bus.

D

μC/FS Types and Structures

Your application may need to access or populate the types and structures described in this appendix. Each of the user-accessible structures is presented in alphabetical order. The following information is provided for each entry:

- A brief description of the type or structure.
- The definition of the type or structure.
- The filename of the source code.
- A description of the meaning of the type or the members of the structure.
- Specific notes and warnings regarding use of the type.

D-1 FS_CFG

```
typedef struct fs_cfg {
    FS_QTY DevCnt;
    FS_QTY VolCnt;
    FS_QTY FileCnt;
    FS_QTY DirCnt;
    FS_QTY BufCnt;
    FS_QTY DevDrvCnt;
    FS_SEC_SIZE MaxSecSize;
} FS_CFG;
```

File	Used for
fs.h	First argument of <code>FS_Init()</code>

A pointer to a `FS_CFG` structure is the argument of `FS_Init()`. It configures the number of devices, files and other objects in the file system suite.

MEMBERS

- DevCnt** The maximum number of devices that can be open simultaneously. MUST be greater than or equal to 1.
- VolCnt** The maximum number of volumes that can be open simultaneously. MUST be greater than or equal to 1.
- FileCnt** The maximum number of files that can be open simultaneously. MUST be greater than or equal to 1.
- DirCnt** Maximum number of directories that can be open simultaneously. If `DirCnt` is 0, the directory module functions will be blocked after successful initialization, and the file system will operate as if compiled with directory support disabled. If directory support is disabled, `DirCnt` is ignored; otherwise, if directories will be used, `DirCnt` should be greater than or equal to 1.

BufCnt Maximum number of buffers that can be used successfully. The minimum necessary BufCnt can be calculated from the number of volumes:

$$\text{BufCnt} \geq \text{VolCnt} * 2$$

If `FSEntry_Copy()` or `FSEntry_Rename()` is used, then up to one additional buffer for each volume may be necessary.

DevDrvCnt Maximum number of device drivers that can be added. It MUST be greater than or equal to 1.

MaxSecSize Maximum sector size, in octets. It must be 512, 1024, 2048 or 4096. No device with a sector size larger than MaxSecSize can be opened.

NOTES

None.

D-2 FS_DEV_INFO

```
typedef struct fs_dev_info {
    FS_STATE      State;
    FS_SEC_QTY    Size;
    FS_SEC_SIZE   SecSize;
    CPU_BOOLEAN   Fixed;
} FS_DEV_INFO;
```

File	Used for
fs_dev.h	Second argument of FSDev_Query()

Receives information about a device.

MEMBERS

State The device state:

FS_DEV_STATE_CLOSED	Device is closed.
FS_DEV_STATE_CLOSING	Device is closing.
FS_DEV_STATE_OPENING	Device is opening.
FS_DEV_STATE_OPEN	Device is open, but not present.
FS_DEV_STATE_PRESENT	Device is present, but not low-level formatted.
FS_DEV_STATE_LOW_FMT_VALID	Device low-level format is valid.

Size The number of sectors on the device.

SecSize The size of each device sector.

Fixed Indicates whether the device is fixed or removable.

NOTES

None.

D-3 FS_DEV_NOR_CFG

```
typedef struct fs_dev_nor_cfg {
    CPU_ADDR          AddrBase;
    CPU_INT08U        RegionNbr;
    CPU_ADDR          AddrStart;
    CPU_INT32U        DevSize;
    FS_SEC_SIZE       SecSize;
    CPU_INT08U        PctRsvd;
    CPU_INT16U        EraseCntDiffTh;
    FS_DEV_NOR_PHY_API *PhyPtr;
    CPU_INT08U        BusWidth;
    CPU_INT08U        BusWidthMax;
    CPU_INT08U        PhyDevCnt;
    CPU_INT32U        MaxClkFreq;
} FS_DEV_NOR_CFG;
```

File	Used for
fs_dev_nor.h	Second argument of FSDev_Open() (when opening a NOR device)

Configures the properties of a NOR device that will be opened. A pointer to this structure is passed as the second argument of FSDev_Open() for a NOR device.

MEMBERS

AddrBase *must* specify

1. the base address of the NOR flash memory, for a parallel NOR.
2. 0x00000000 for a serial NOR.

RegionNbr *must* specify the block region which will be used for the file system area. Block regions are enumerated by the physical-layer driver; for more information, see the physical-layer driver header file. (on monolithic devices, devices with only one block region, this *must* be 0).

AddrStart *must* specify

1. the absolute start address of the file system area in the NOR flash memory, for a paralel NOR.

2. the offset of the start of the file system in the NOR flash, for a serial NOR.

The address specified by **AddrStart** MUST lie within the region RegionNbr.

DevSize *must* specify the number of octets that will belong to the file system area.

SecSize *must* specify the sector size for the NOR flash (either 512, 1024, 2048 or 4096).

PctRsvd *must* specify the percentage of sectors on the NOR flash that will be reserved for extra-file system storage (to improve efficiency). This value must be between 5% and 35%, except if 0 is specified whereupon the default will be used (10%).

EraseCntDiffTh *must* specify the difference between minimum and maximum erase counts that will trigger passive wear-leveling. This value must be between 5 and 100, except if 0 is specified whereupon the default will be used (20).

PhyPtr *must* point to the appropriate physical-layer driver:

FSDev_NOR_AMD_1x08 CFI-compatible parallel NOR
 implementing AMD command set, 8-bit data bus.

FSDev_NOR_AMD_1x16 CFI-compatible parallel NOR
 implementing AMD command set, 16-bit data bus.

FSDev_NOR_Intel_1x16 CFI-compatible parallel NOR
 implementing Intel command set, 16-bit data bus

FSDev_NOR_SST39 SST SST39 Multi-Purpose Flash

FSDev_NOR_STM25	ST M25 serial flash
FSDev_NOR_SST25	SST SST25 serial flash
Other	User-developed

For a parallel NOR, the bus configuration is specified via **BusWidth**, **BusWidthMax** and **PhyDevCnt**:

BusWidth is the bus width, in bits, between the MCU/MPU and each connected device.

BusWidthMax is the maximum width supported by each connected device.

PhyDevCnt is the number of devices interleaved on the bus.

For a serial flash, the maximum clock frequency is specified via **MaxClkFreq**.

NOTES

None.

D-4 FS_DEV_RAM_CFG

```
typedef struct fs_dev_ram_cfg {  
    FS_SEC_SIZE  SecSize;  
    FS_SEC_QTY   Size;  
    void         *DiskPtr;  
} FS_DEV_RAM_CFG;
```

File	Used for
fs_dev_ramdisk.h	Second argument of <code>FSDev_Open()</code> (when opening a RAM disk)

Configures the properties of a RAM disk that will be opened. A pointer to this structure is passed as the second argument of `FSDev_Open()` for a RAM disk.

MEMBERS

- SecSize** The sector size of RAM disk, either 512, 1024, 2048 or 4096.
- Size** The size of the RAM disk, in sectors.
- DiskPtr** The pointer to the RAM disk.

NOTES

None.

D-5 FS_DIR_ENTRY (struct fs_dirent)

```
typedef struct fs_dirent {
    CPU_CHAR      Name[FS_CFG_MAX_FILE_NAME_LEN + 1u];
    FS_ENTRY_INFO Info;

} FS_DIR_ENTRY;
```

File	Used for
fs_dir.h	Second argument of <code>fs_readdir_r()</code> and <code>FSDir_Rd()</code>

Receives information about a directory entry.

MEMBERS

Name The name of the file.

Info Entry information. For more information, see section D-2 “FS_DEV_INFO” on page 484

NOTES

None.

D-6 FS_ENTRY_INFO

```
typedef struct fs_entry_info {
    FS_FLAGS      Attrib;
    FS_FILE_SIZE  Size;
    CLK_TS_SEC    DateTimeCreate;
    CLK_TS_SEC    DateAccess;
    CLK_TS_SEC    DateTimeWr;
    FS_SEC_QTY    BlkCnt;
    FS_SEC_SIZE   BlkSize;
} FS_ENTRY_INFO;
```

File	Used for
fs_entry.h	Second argument of FSEntry_Query() and FSFileQuery();

The Info member of FS_DIR_ENTRY (struct fs_dirent)

Receives information about a file or directory.

MEMBERS

Attrib The file or directory attributes (see section 6-2-1 “File and Directory Attributes” on page 90).

Size The size of the file, in octets.

DateTimeCreate The creation timestamp of the file or directory.

DateAccess The last access date of the file or directory.

DateTimeWr The last write (or modification) timestamp of the file or directory.

BlkCnt	The number of blocks allocated to the file. For a FAT file system, this is the number of clusters occupied by the file data.
BlkSize	The size of each block allocated in octets. For a FAT file system, this is the size of a cluster.

NOTES

None.

D-7 FS_FAT_SYS_CFG

```
typedef struct fs_fat_sys_cfg {
    FS_SEC_QTY      ClusSize;
    FS_FAT_SEC_NBR  RsvdAreaSize;
    CPU_INT16U      RootDirEntryCnt;
    CPU_INT08U      FAT_Type;
    CPU_INT08U      NbrFATs;
} FS_FAT_SYS_CFG;
```

File	Used for
fs_fat_type.h	Second argument of <code>FSVol_Fmt()</code> when opening a FAT volume (optional)

A pointer to a `FS_FAT_SYS_CFG` structure may be passed as the second argument of `FSVol_Fmt()`. It configures the properties of the FAT file system that will be created.

MEMBERS

- ClusSize** The size of a cluster, in sectors. This should be 1, 2, 4, 8, 16, 32, 64 or 128. The size of a cluster, in bytes, must be less than or equal to 65536, so some of the upper values may be invalid for devices with large sector sizes.
- RsvdAreaSize** The size of the reserved area on the disk, in sectors. For FAT12 and FAT16 volumes, the reserved should be 1 sector; for FAT32 volumes, 32 sectors.
- RootDirEntryCnt** The number of entries in the root directory. This applies only to FAT12 and FAT16 volumes, on which the root directory is a separate area of the file system and is a fixed size. The root directory entry count caps the number of files and directories that can be located in the root directory.
- FAT_Type** The type of FAT. This should be 12 (for FAT12), 16 for (FAT16) or 32 (for FAT32). This choice of FAT type must observe restrictions on the maximum number a clusters. A FAT12 file system may have no more than 4085 clusters; a FAT16 file system, no more than 65525.

NbrFATs The number of actual FATs (file allocation tables) to create on the disk. The typical value is 2 (one for primary use, a secondary for backup).

NOTES

Further restrictions on the members of this structure can be found in Chapter 4, “File Systems: FAT” on page 153.

D-8 FS_PARTITION_ENTRY

```
typedef struct fs_partition_entry {  
    FS_SEC_NBR  Start;  
    FS_SEC_QTY  Size;  
    CPU_INT08U  Type;  
} FS_PARTITION_ENTRY;
```

File	Used for
fs_partition.h	Third argument of FSDev_PartitionFind()

Receives information about a partition entry.

MEMBERS

- Start** The start sector of partition.
- Size** The size of partition, in sectors.
- Type** The type of data in the partition.

NOTES

None.

D-9 FS_VOL_INFO

```
typedef struct fs_vol_info {
    FS_STATE      State;
    FS_STATE      DevState;
    FS_SEC_QTY    DevSize;
    FS_SEC_SIZE   DevSecSize;
    FS_SEC_QTY    PartitionSize;
    FS_SEC_QTY    VolBadSecCnt;
    FS_SEC_QTY    VolFreeSecCnt;
    FS_SEC_QTY    VolUsedSecCnt;
    FS_SEC_QTY    VolTotSecCnt;
} FS_VOL_INFO;
```

File	Used for
fs_vol.h	Second argument of FSVol_Query()

Receives information about a volume.

MEMBERS

State The volume state:

FS_VOL_STATE_CLOSED	Volume is closed.
FS_VOL_STATE_CLOSING	Volume is closing.
FS_VOL_STATE_OPENING	Volume is opening.
FS_VOL_STATE_OPEN	Volume is open.
FS_VOL_STATE_PRESENT	Volume device is present.
FS_VOL_STATE_MOUNTED	Volume is mounted.

DevState The device state:

FS_DEV_STATE_CLOSED	Device is closed.
FS_DEV_STATE_CLOSING	Device is closing.
FS_DEV_STATE_OPENING	Device is opening.
FS_DEV_STATE_OPEN	Device is open, but not present.
FS_DEV_STATE_PRESENT	Device is present, but not low-level formatted.
FS_DEV_STATE_LOW_FMT_VALID	Device low-level format is valid.

DevSize	The number of sectors on the device.
DevSecSize	The size of each device sector.
PartitionSize	The number of sectors in the partition.
VolBadSecCnt	The number of bad sectors on the volume.
VolFreeSecCnt	The number of free sectors on the volume.
VolUsedSecCnt	The number of used sectors on the volume.
VolTotSecCnt	The total number of sectors on the volume.

NOTES

None.

E

μC/FS Configuration

μC/FS is configurable at compile time via approximately 30 #defines in an application's `fs_cfg.h` file. μC/FS uses #defines because they allow code and data sizes to be scaled at compile time based on enabled features. In other words, this allows the ROM and RAM footprints of μC/FS to be adjusted based on your requirements.

Most of the #defines should be configured with the default configuration values. This leaves about a dozen or so values that should be configured with values that may deviate from the default configuration.

E-1 FILE SYSTEM CONFIGURATION

Core file system modules may be selectively disabled.

FS_CFG_BUILD

`FS_CFG_BUILD` selects the file system build. Should always be set to `FS_BUILD_FULL` in this release.

FS_CFG_SYS_DRV_SEL

`FS_CFG_SYS_DRV_SEL` selects which file system driver(s) will be included. Currently, there is only one option. When `FS_SYS_DRV_SEL_FAT`, the FAT system driver will be included.

FS_CFG_CACHE_EN

`FS_CFG_CACHE_EN` enables (when set to `DEF_ENABLED`) or disables (when set to `DEF_DISABLED`) code generation of volume cache functions.

Function	File
<code>FSVol_CacheAssign()</code>	<code>fs_vol.c</code>
<code>FSVol_CacheFlush()</code>	<code>fs_vol.c</code>
<code>FSVol_CacheInvalidate()</code>	<code>fs_vol.c</code>

Table E-1 **Cache function exclusion**

These functions are not included if `FS_CFG_CACHE_EN` is `DEF_DISABLED`

FS_CFG_BUF_ALIGN_OCTETS

`FS_CFG_BUF_ALIGN_OCTETS` configures the minimum alignment of the internal buffers in octets. This should be set to the maximum alignment required by the any of the CPU, system buses and, if relevant, the peripherals and DMA controller involved in the file system operations. When no minimum alignment is required `FS_CFG_BUF_ALIGN_OCTETS` should generally be set to the platform natural alignment for performance reasons.

FS_CFG_API_EN

`FS_CFG_API_EN` enables (when set to `DEF_ENABLED`) or disables (when set to `DEF_DISABLED`) code generation of the POSIX API functions. This API includes functions like `fs_fopen()` or `fs_opendir()` which mirror standard POSIX functions like `fopen()` or `opendir()`.

FS_CFG_DIR_EN

FS_CFG_DIR_EN enables (when set to DEF_ENABLED) or disables (when set to DEF_DISABLED) code generation of directory access functions. When disabled, the functions in the following table will not be available.

Function	File
fs_opendir()	fs_api.c
fs_closedir()	fs_api.c
fs_readdir_r()	fs_api.c
FSDir_Open()	fs_dir.c
FSDir_Close()	fs_dir.c
FSDir_Rd()	fs_dir.c

Table E-2 **Directory function exclusion**

These functions are not included if FS_CFG_DIR_EN is DEF_DISABLED

E-2 FEATURE INCLUSION CONFIGURATION

Individual file system features may be selectively disabled.

FS_CFG_FILE_BUF_EN

FS_CFG_BUF_EN enables (when set to DEF_ENABLED) or disables (when set to DEF_DISABLED) code generation of file buffer functions. When disabled, the functions in the following table will not be available.

Function	File
fs_fflush()	fs_api.c
fs_setbuf()	fs_api.c
fs_setvbuf()	fs_api.c
FSFile_BufAssign()	fs_file.c
FSFile_BufFlush()	fs_file.c

Table E-3 File buffer function exclusion

These functions are not included if FS_CFG_FILE_BUF_EN is DEF_DISABLED

FS_CFG_FILE_LOCK_EN

FS_CFG_FILE_LOCK_EN enables (when set to DEF_ENABLED) or disables (when set to DEF_DISABLED) code generation of file lock functions. When enabled, a file can be locked across several operations; when disabled, a file is only locked during a single operation and the functions in the following table will not be available.

Function	File
fs_flockfile()	fs_api.c
fs_funlockfile()	fs_api.c
fs_ftrylockfile()	fs_api.c
FSFile_LockGet()	fs_file.c
FSFile_LockSet()	fs_file.c
FSFile_LockAccept()	fs_file.c

Table E-4 File lock function exclusion

These functions are not included if FS_CFG_FILE_LOCK_EN is DEF_DISABLED

FS_CFG_PARTITION_EN

When `FS_CFG_PARTITION_EN` is enabled (`DEF_ENABLED`), volumes can be opened on secondary partitions and partitions can be created. When it is disabled (`DEF_DISABLED`), volumes can be opened only on the first partition and the functions in the following table will not be available. The function `FSDev_PartitionInit()`, which initializes the partition structure on a volume, will be included in both configurations.

Function	File
<code>FSDev_GetNbrPartitions()</code>	<code>fs_dev.c</code>
<code>FSDev_PartitionAdd()</code>	<code>fs_dev.c</code>
<code>FSDev_PartitionFind()</code>	<code>fs_dev.c</code>

Table E-5 **Partition function exclusion**

These functions are *not* included if `FS_CFG_PARTITION_EN` is `DEF_DISABLED`.

FS_CFG_WORKING_DIR_EN

When `FS_CFG_WORKING_DIR_EN` is enabled (`DEF_ENABLED`), file system operations can be performed relative to a working directory. When it is disabled (`DEF_DISABLED`), all file system operations must be performed on absolute paths and the functions in the following table will not be available.

Function	File
<code>fs_chdir()</code>	<code>fs_api.c</code>
<code>fs_getcwd()</code>	<code>fs_api.c</code>
<code>FS_WorkingDirGet()</code>	<code>fs.h</code>
<code>FS_WorkingDirSet()</code>	<code>fs.h</code>

Table E-6 **Working directory function exclusion**

These functions are not included if `FS_CFG_WORKING_DIR_EN` is `DEF_DISABLED`

FS_CFG_UTF8_EN

FS_CFG_UTF8_EN selects whether file names may be specified in UTF-8. When enabled (DEF_ENABLED), file names may be specified in UTF-8; when disabled (DEF_DISABLED), file names must be specified in ASCII.

FS_CFG_CONCURRENT_ENTRIES_ACCESS_EN

FS_CFG_CONCURRENT_ENTRIES_ACCESS_EN selects whether one file can be open multiple times (in one or more task). When enabled (DEF_ENABLED), files may be open concurrently multiple times and without protection. When disabled (DEF_DISABLED), files may be open concurrently only in read-only mode, but may not be open concurrently in write mode. This option makes the file system safer when disabled.

FS_CFG_RD_ONLY_EN

FS_CFG_RD_ONLY_EN selects whether write access to files, volumes and devices will be possible. When DEF_ENABLED, files, volumes and devices may only be read—code for write operations will not be included and the functions in the following table will not be available.

Function	File
fs_fwrite()	fs_api.c
fs_remove()	fs_api.c
fs_rename()	fs_api.c
fs_mkdir()	fs_api.c
fs_truncate()	fs_api.c
fs_mkdir()	fs_api.c
FSDev_PartitionAdd()	fs_dev.c
FSDev_PartitionInit()	fs_dev.c
FSDev_Wr()	fs_dev.c
FSEntry_AttribSet()	fs_entry.c
FSEntry_Copy()	fs_entry.c
FSEntry_Create()	fs_entry.c
FSEntry_TimeSet()	fs_entry.c
FSEntry_Del()	fs_entry.c
FSEntry_Rename()	fs_entry.c

Function	File
FSFile_Truncate()	fs_file.c
FSFile_Wr()	fs_file.c
FSVol_Fmt()	fs_vol.c
FSVol_LabelSet()	fs_vol.c
FSVol_Wr()	fs_vol.c

Table E-7 Read only function exclusion (continued)

These functions are not included if **FS_CFG_RD_ONLY_EN** is **DEF_ENABLED**

FS_CFG_64_BITS_LBA_EN

FS_CFG_64_BIT_LBA_EN selects whether support for 64 logical block addressing (LBA) is enabled. When **DEF_ENABLED** support 64-bit LBA will be included otherwise LBA will be limited to 32 bit. Applications that need support for 48-bit LBA should set this feature to **DEF_ENABLED**.

E-3 NAME RESTRICTION CONFIGURATION

Individual file system features may be selectively disabled.

FS_CFG_MAX_PATH_NAME_LEN

FS_CFG_MAX_PATH_NAME_LEN configures the maximum path name length, in characters (not including the final NULL character). The default value is 260 (the maximum path name length for paths on FAT volumes).

FS_CFG_MAX_FILE_NAME_LEN

FS_CFG_MAX_FILE_NAME_LEN configures the maximum file name length, in characters (not including the final NULL character). The default value is 255 (the maximum file name length for FAT long file names).

FS_CFG_MAX_DEV_DRV_NAME_LEN

FS_CFG_MAX_DEV_DRV_NAME_LEN configures the maximum device driver name length, in characters (not including the final NULL character). The default value is 10.

FS_CFG_MAX_DEV_NAME_LEN

FS_CFG_MAX_DEV_NAME_LEN configures the maximum device name length, in characters (not including the final NULL character). The default value is 15.

FS_CFG_MAX_VOL_NAME_LEN

FS_CFG_MAX_VOL_NAME_LEN configures the maximum volume name length, in characters (not including the final NULL character). The default value is 10.

E-4 DEBUG CONFIGURATION

A fair amount of code in μ C/FS has been included to simplify debugging. There are several configuration constants used to aid debugging.

FS_CFG_DBG_MEM_CLR_EN

FS_CFG_DBG_MEM_CLR_EN is used to clear internal file system data structures when allocated or deallocated. When DEF_ENABLED, internal file system data structures will be cleared.

FS_CFG_DBG_WR_VERIFY_EN

FS_CFG_DBG_WR_VERIFY_EN is used verify writes by reading back data. This is a particularly convenient feature while debugging a driver.

E-5 ARGUMENT CHECKING CONFIGURATION

Most functions in μ C/FS include code to validate arguments that are passed to it. Specifically, μ C/FS checks to see if passed pointers are NULL, if arguments are within valid ranges, etc. The following constants configure additional argument checking.

FS_CFG_ARG_CHK_EXT_EN

FS_CFG_ARG_CHK_EXT_EN allows code to be generated to check arguments for functions that can be called by the user and for functions which are internal but receive arguments from an API that the user can call.

FS_CFG_ARG_CHK_DBG_EN

FS_CFG_ARG_CHK_DBG_EN allows code to be generated which checks to make sure that pointers passed to functions are not NULL, that arguments are within range, etc.:

E-6 FILE SYSTEM COUNTER CONFIGURATION

μC/FS contains code that increments counters to keep track of statistics such as the number of packets received, the number of packets transmitted, etc. Also, μC/FS contains counters that are incremented when error conditions are detected.

FS_CFG_CTR_STAT_EN

FS_CFG_CTR_STAT_EN determines whether the code and data space used to keep track of statistics will be included. When DEF_ENABLED, statistics counters will be maintained.

FS_CFG_CTR_ERR_EN

FS_CFG_CTR_STAT_EN determines whether the code and data space used to keep track of errors will be included. When DEF_ENABLED, error counters will be maintained.

E-7 FAT CONFIGURATION

Configuration constants can be used to enable/disable features within the FAT file system driver.

FS_FAT_CFG_LFN_EN

FS_FAT_CFG_LFN_EN is used to control whether long file names (LFNs) are supported. When DEF_DISABLED, all file names must be valid 8.3 short file names.

FS_FAT_CFG_FAT12_EN

FS_FAT_CFG_FAT12_EN is used to control whether FAT12 is supported. When DEF_DISABLED, FAT12 volumes can not be opened, nor can a device be formatted as a FAT12 volume.

FS_FAT_CFG_FAT16_EN

FS_FAT_CFG_FAT16_EN is used to control whether FAT16 is supported. When DEF_DISABLED, FAT16 volumes can not be opened, nor can a device be formatted as a FAT16 volume.

FS_FAT_CFG_FAT32_EN

FS_FAT_CFG_FAT32_EN is used to control whether FAT32 is supported. When DEF_DISABLED, FAT32 volumes can not be opened, nor can a device be formatted as a FAT32 volume.

FS_FAT_CFG_JOURNAL_EN

FS_FAT_CFG_JOURNAL_EN selects whether journaling functions will be present. When DEF_ENABLED, journaling functions are present; when DEF_DISABLED, journaling functions are NOT present. If disabled, the functions in Table E-8 will not be available.

Function	File
FS_FAT_JournalOpen()	fs_fat_journal.c/.h
FS_FAT_JournalClose()	fs_fat_journal.c/.h
FS_FAT_JournalStart()	fs_fat_journal.c/.h
FS_FAT_JournalEnd()	fs_fat_journal.c/.h

Table E-8 Journaling function exclusion

These functions are NOT included if FS_FAT_CFG_JOURNAL_EN is DEF_DISABLED

FS_FAT_CFG_VOL_CHK_EN

FS_FAT_CFG_VOL_CHK_EN selects whether volume check is supported. When DEF_ENABLED, volume check is supported; when DEF_DISABLED, the function FS_FAT_VolChk() will not be available.

FS_FAT_CFG_VOL_CHK_MAX_LEVELS

FS_FAT_CFG_VOL_CHK_MAX_LEVELS specifies the maximum number of directory levels that will be checked by the volume check function. Each level requires an additional 12 bytes stack space.

E-8 SD/MMC SPI CONFIGURATION

FS_DEV_SD_SPI_CFG_CRC_EN

Data blocks received from the card are accompanied by CRCs, as are the blocks transmitted to the card. FS_DEV_SD_SPI_CFG_CRC_EN enables CRC validation by the card, as well as the generation and checking of CRCs. If DEF_ENABLED, CRC generation and checking will be performed.

E-9 TRACE CONFIGURATION

The file system debug trace is enabled by #define'ing `FS_TRACE_LEVEL` in your application's `fs_cfg.h`:

```
#define FS_TRACE_LEVEL                TRACE_LEVEL_DBG
```

The valid trace levels are described in the table below. A trace functions should also be defined:

```
#define FS_TRACE                      printf
```

This should be a printf-type function that redirects the trace output to some accessible terminal (for example, the terminal I/O window within your debugger, or a serial port) . When porting a driver to a new platform, this information can be used to debug the fledgling port.

Trace Level	Meaning
<code>TRACE_LEVEL_OFF</code>	No trace.
<code>TRACE_LEVEL_INFO</code>	Basic event information (e.g., volume characteristics).
<code>TRACE_LEVEL_DBG</code>	Debug information.
<code>TRACE_LEVEL_LOG</code>	Event log.

Table E-9 Trace levels

F

Shell Commands

The command line interface is a traditional method for accessing the file system on a remote system, or in a device with a serial port (be that RS-232 or USB). A group of shell commands, derived from standard UNIX equivalents, are available for μ C/FS. These may simply expedite evaluation of the file system suite, or become part a primary method of access (or gathering debug information) in your final product.

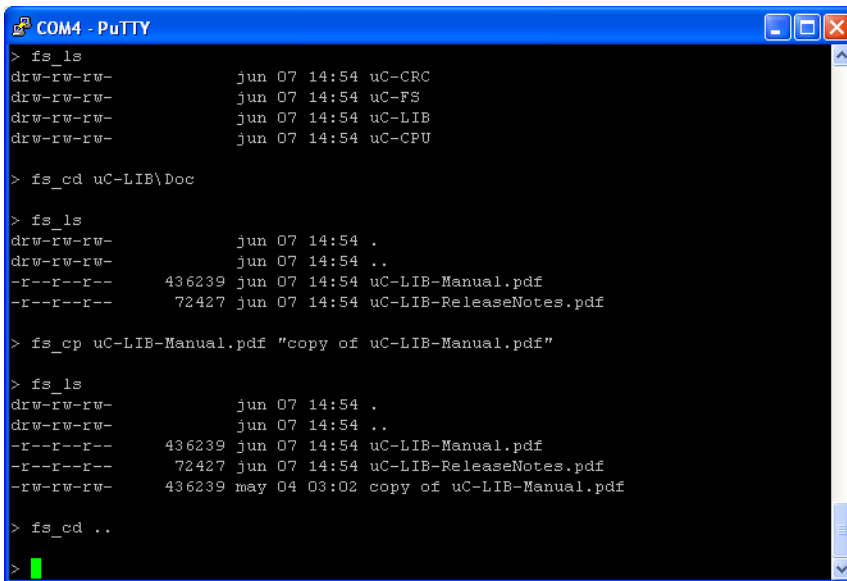

```
COM4 - PuTTY
> fs_ls
drw-rw-rw-   jun 07 14:54 uC-CRC
drw-rw-rw-   jun 07 14:54 uC-FS
drw-rw-rw-   jun 07 14:54 uC-LIB
drw-rw-rw-   jun 07 14:54 uC-CPU

> fs_cd uC-LIB\Doc

> fs_ls
drw-rw-rw-   jun 07 14:54 .
drw-rw-rw-   jun 07 14:54 ..
-r--r--r--  436239 jun 07 14:54 uC-LIB-Manual.pdf
-r--r--r--  72427  jun 07 14:54 uC-LIB-ReleaseNotes.pdf

> fs_cp uC-LIB-Manual.pdf "copy of uC-LIB-Manual.pdf"

> fs_ls
drw-rw-rw-   jun 07 14:54 .
drw-rw-rw-   jun 07 14:54 ..
-r--r--r--  436239 jun 07 14:54 uC-LIB-Manual.pdf
-r--r--r--  72427  jun 07 14:54 uC-LIB-ReleaseNotes.pdf
-rw-rw-rw-  436239 may 04 03:02 copy of uC-LIB-Manual.pdf

> fs_cd ..
>
```

Figure F-1 μ C/FS shell command usage

F-1 FILES AND DIRECTORIES

μ C/FS with the shell commands (and μ C/Shell) is organized into the directory structure shown in Figure F-2. The files constituting the shell commands are outlined in this section; the generic file-system files, outlined in Chapter 3, “ μ C/FS Directories and Files” on page 29, are also required.

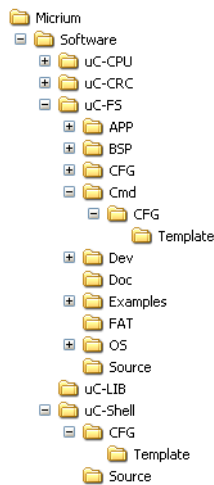

Figure F-2 Directory structure

\Micrium\Software\uC-FS\Cmd

`fs_shell.*` contain the shell commands for μ C/FS.

\Micrium\Software\uC-FS\Cmd\Template\Cfg

`fs_shell_cfg.h` is the template configuration file for the μ C/FS shell commands. This file should be copied to your application directory and modified.

\Micrium\Software\uC-Shell

This directory contains μ C/Shell, which is used to process the commands. See the μ C/Shell user manual for more information.

F-2 USING THE SHELL COMMANDS

To use shell commands, four files, in addition to the generic file system files, must be included in the build:

- `fs_shell.c`
- `fs_shell.h`
- `shell.c` (located in `\Micrium\Software\uC-Shell\Source`)
- `shell.h` (located in `\Micrium\Software\uC-Shell\Source`)

The file `fs_shell.h` and `shell.h` must also be `#included` in any application or header files initialize `µC/Shell` or handle shell commands. The shell command configuration file (`fs_shell_cfg.h`) should be copied to your application directory and modified. The following directories must be on the project include path:

- `\Micrium\Software\uC-FS\Cmd`
- `\Micrium\Software\uC-Shell\Source`

`µC/Shell` with the `µC/FS` shell commands is initialized in Listing F-1. The file system initialization (`FS_Init()`) function should have previously been called.

```
CPU_BOOLEAN App_ShellInit (void)
{
    CPU_BOOLEAN ok;
    ok = Shell_Init();
    if (ok == DEF_FAIL) {
        return (DEF_FAIL);
    }

    ok = FSShell_Init();
    if (ok == DEF_FAIL) {
        return (DEF_FAIL);
    }
    return (DEF_OK);
}
```

Listing F-1 Initializing `µC/Shell`

It's assumed that the application will create a task to receive input from a terminal; this task should be written as shown in Listing F-2.

```

void App_ShellTask (void *p_arg)
{
    CPU_CHAR          cmd_line[MAX_CMD_LEN];
    SHELL_ERR         err;
    SHELL_CMD_PARAM   cmd_param;
    CPU_CHAR          cwd_path[FS_CFG_FULL_NAME_LEN + 1u];

                                /* Init cmd param (see Note #1). */
    Str_Copy(&cwd_path[0], (CPU_CHAR *)"\");
    cmd_param.pcur_working_dir = (void *)cwd_path[0];
    cmd_param.pout_opt        = (void *)0;

    while (DEF_TRUE) {
        App_ShellIn(cmd_line, MAX_CMD_LEN);          /* Rd cmd      (see Note #2). */
                                                    /* Exec cmd   (see Note #3). */
        Shell_Exec(cmd_line, App_ShellOut, &cmd_param, &err);
        switch (err) {
            case SHELL_ERR_CMD_NOT_FOUND:
            case SHELL_ERR_CMD_SEARCH:
            case SHELL_ERR_ARG_TBL_FULL:
                App_ShellOut("Command not found\r\n", 19, cmd_param.pout_opt);
                break;
            default:
                break;
        }
    }
}

/*
*****
*                               App_ShellIn()
*****1*****
*/
CPU_INT16S App_ShellIn (CPU_CHAR   *pbuf,
                       CPU_INT16U  buf_len)
{
    /* $$$$ Store line from terminal/command line into 'pbuf'; return length of line. */
}

```

```

/*
*****
*
*                               App_ShellOut()
*****1*****
*/
CPU_INT16S App_ShellOut (CPU_CHAR   *pbuf,
                        CPU_INT16U  buf_len,
                        void         *popt)
{
    /* $$$ Output 'pbuf' data on terminal/command line; return nbr bytes tx'd. */
}

```

Listing F-2 Executing shell commands & handling shell output

- LF-2(1) The `SHELL_CMD_PARAM` structure that will be passed to `Shell_Exec()` must be initialized. The `pcur_working_dir` member *must* be assigned a pointer to a string of at least `FS_SHELL_CFG_MAX_PATH_LEN` characters. This string must have been initialized to the default working directory path; if the root directory, “\”.

- LF-2(2) The next command, ending with a newline, should be read from the command line.

- LF-2(3) The received command should be executed with `Shell_Exec()`. If the command is a valid command, the appropriate command function will be called. For example, the command “`fs_ls`” will result in `FSShell_ls()` in `fs_shell.c` being called. `FSShell_ls()` will then print the entries in the working directory to the command line with the output function `App_ShellOut()`, passed as the second argument of `Shell_Exec()`.

F-3 COMMANDS

The supported commands, listed in the table below, are equivalent to the standard UNIX commands of the same names, though the functionality is typically simpler, with few or no special options.

Command	Description
fs_cat	Print file contents to the terminal output.
fs_cd	Change the working directory.
fs_cp	Copy a file.
fs_date	Write the date and time to terminal output, or set the system date and time
fs_df	Report disk free space.
fs_ls	List directory contents.
fs_mkdir	Make a directory.
fs_mkfs	Format a volume.
fs_mount	Mount volume.
fs_mv	Move files.
fs_od	Dump file contents to terminal output.
fs_pwd	Write to terminal output pathname of current working directory.
fs_rm	Remove a directory entry.
fs_rmdir	Remove a directory.
fs_touch	Change file modification time.
fs_umount	Unmount volume.
fs_wc	Determine the number of newlines, words and bytes in a file.

Table F-1 **Commands**

Information about each command can be obtained using the help (-h) option:

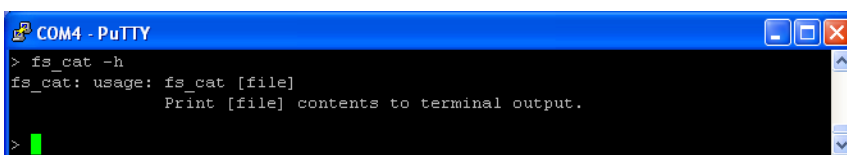

```

COM4 - PuTTY
> fs_cat -h
fs_cat: usage: fs_cat [file]
          Print [file] contents to terminal output.
>
  
```

Figure F-3 **Help option output**

F-3-1 fs_cat

Print file contents to the terminal output.

USAGES

```
fs_cat [file]
```

ARGUMENTS

file Path of file to print to terminal output.

OUTPUT

File contents, in the ASCII character set. Non-printable/non-space characters are transmitted as full stops (“periods”, character code 46). For a more convenient display of binary files use `fs_od`.

REQUIRED CONFIGURATION

Available only if `FS_SHELL_CFG_CAT_EN` is `DEF_ENABLED`.

NOTES/WARNINGS

None.

F-3-2 fs_cd

Change the working directory.

USAGES

```
fs_cd [dir]
```

ARGUMENTS

dir Absolute directory path.

OR

Path relative to current working directory.

OUTPUT

None.

REQUIRED CONFIGURATION

Available only if `FS_SHELL_CFG_CD_EN` is `DEF_ENABLED`.

NOTES/WARNINGS

The new working directory is formed in three steps:

- 1 If the argument `dir` begins with the path separator character (slash, '\') or a volume name, it will be interpreted as an absolute directory path and will become the preliminary working directory. Otherwise the preliminary working directory path is formed by the concatenation of the current working directory, a path separator character and `dir`.

-
- 2 The preliminary working directory path is then refined, from the first to last path component:
 - a. If the component is a 'dot' component, it is removed
 - b. If the component is a 'dot dot' component, and the preliminary working directory path is not NULL, the previous path component is removed. In any case, the 'dot dot' component is removed.
 - c. Trailing path separator characters are removed, and multiple path separator characters are replaced by a single path separator character.
 - 3 The volume is examined to determine whether the preliminary working directory exists. If it does, it becomes the new working directory. Otherwise, an error is output, and the working directory is unchanged.

F-3-3 fs_cp

Copy a file.

USAGES

```
fs_cp [source_file] [dest_file]
```

```
fs_cp [source_file] [dest_dir]
```

ARGUMENTS

source_file Source file path.

dest_file Destination file path.

dest_dir Destination directory path.

OUTPUT

None.

REQUIRED CONFIGURATION

Available only if `FS_SHELL_CFG_CP_EN` is `DEF_ENABLED` and `FS_CFG_RD_ONLY_EN` is `DEF_DISABLED`.

NOTES/WARNINGS

In the first form of this command, neither argument may be an existing directory. The contents of `source_file` will be copied to a file named `dest_file` located in the same directory as `source_file`.

In the second form of this command, the first argument must not be an existing directory and the second argument must be an existing directory. The contents of `source_file` will be copied to a file with name formed by concatenating `dest_dir`, a path separator character and the final component of `source_file`.

F-3-4 fs_date

Write the date and time to terminal output, or set the system date and time.

USAGES

`fs_date`

`fs_date [time]`

ARGUMENTS

`time` If specified, time to set, in the form mmddhhmmccyy:

1st mm	the month (1-12)
dd	the day (1-29, 30 or 31)
hh	the hour (0-23)
2nd mm	the minute (0-59)
ccyy	the year (1900 or larger)

OUTPUT

If no argument, date and time.

REQUIRED CONFIGURATION

Available only if `FS_SHELL_CFG_DATE_EN` is `DEF_ENABLED`.

NOTES/WARNINGS

None.

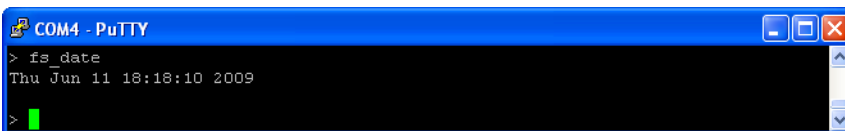

Figure F-4 fs_date output

F-3-5 fs_df

Report disk free space.

USAGES

fs_df

fs_df [vol]

ARGUMENTS

vol If specified, volume on which to report free space. Otherwise, information about all volumes will be output..

OUTPUT

Name, total space, free space and used space of volumes.

REQUIRED CONFIGURATION

Available only if FS_SHELL_CFG_DF_EN is DEF_ENABLED.

NOTES/WARNINGS

None.

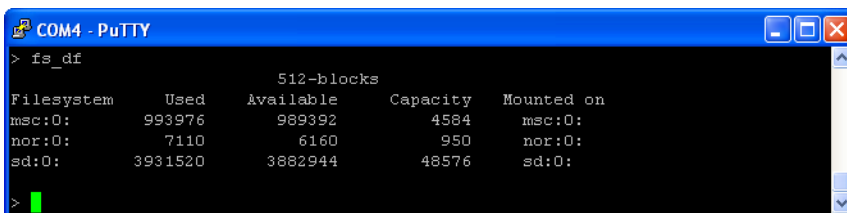

```
COM4 - PuTTY
> fs_df
                    512-blocks
Filesystem   Used   Available   Capacity   Mounted on
msc:0:      993976   989392     4584      msc:0:
nor:0:         7110    6160       950      nor:0:
sd:0:      3931520  3882944   48576     sd:0:
>
```

Figure F-5 fs_df output

F-3-6 fs_ls

List directory contents.

USAGES

fs_ls

ARGUMENTS

None.

OUTPUT

List of directory contents.

REQUIRED CONFIGURATION

Available only if FS_SHELL_CFG_LS_EN is DEF_ENABLED.

NOTES/WARNINGS

The output resembles the output from the standard UNIX command ls -l. See the figure below.

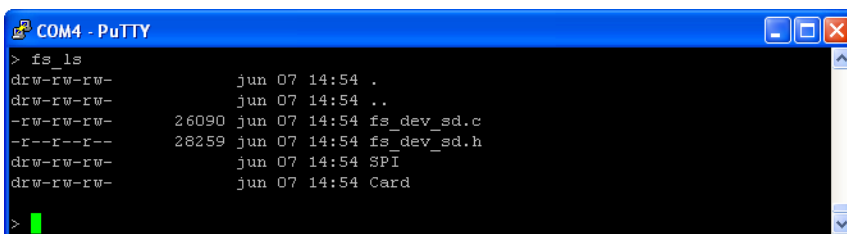

```
COM4 - PuTTY
> fs_ls
drw-rw-rw-      jun 07 14:54 .
drw-rw-rw-      jun 07 14:54 ..
-rw-rw-rw-      26090 jun 07 14:54 fs_dev_sd.c
-r--r--r--      28259 jun 07 14:54 fs_dev_sd.h
drw-rw-rw-      jun 07 14:54 SPI
drw-rw-rw-      jun 07 14:54 Card
>
```

Figure F-6 fs_ls output

F-3-7 fs_mkdir

Make a directory.

USAGES

```
fs_mkdir [dir]
```

ARGUMENTS

dir Directory path.

OUTPUT

None.

REQUIRED CONFIGURATION

Available only if `FS_SHELL_CFG_MKDIR_EN` is `DEF_ENABLED` and `FS_CFG_RD_ONLY_EN` is `DEF_DISABLED`.

NOTES/WARNINGS

None.

F-3-8 fs_mkfs

Format a volume.

USAGES

`fs_mkfs [vol]`

ARGUMENTS

`vol` Volume name.

OUTPUT

None.

REQUIRED CONFIGURATION

Available only if `FS_SHELL_CFG_MKFS_EN` is `DEF_ENABLED` and `FS_CFG_RD_ONLY_EN` is `DEF_DISABLED`.

NOTES/WARNINGS

None.

F-3-9 fs_mount

Mount volume.

USAGES

`fs_mount [dev] [vol]`

ARGUMENTS

`dev` Device to mount.

`vol` Name which will be given to volume.

OUTPUT

None.

REQUIRED CONFIGURATION

Available only if `FS_SHELL_CFG_MOUNT_EN` is `DEF_ENABLED`.

NOTES/WARNINGS

None.

F-3-10 fs_mv

Move files.

USAGES

```
fs_mv [source_entry] [dest_entry]
```

```
fs_mv [source_entry] [dest_dir]
```

ARGUMENTS

source_entry Source entry path.

dest_entry Destination entry path.

dest_dir Destination directory path.

OUTPUT

None.

REQUIRED CONFIGURATION

Available only if **FS_SHELL_CFG_MV_EN** is **DEF_ENABLED** and **FS_CFG_RD_ONLY_EN** is **DEF_DISABLED**.

NOTES/WARNINGS

In the first form of this command, the second argument must not be an existing directory. The file **source_entry** will be renamed **dest_entry**.

In the second form of this command, the second argument must be an existing directory. **source_entry** will be renamed to an entry with name formed by concatenating **dest_dir**, a path separator character and the final component of **source_entry**.

In both forms, if **source_entry** is a directory, the entire directory tree rooted at **source_entry** will be copied and then deleted. Additionally, both **source_entry** and **dest_entry** or **dest_dir** must specify locations on the same volume.

F-3-11 fs_od

Dump file contents to the terminal output.

USAGES

`fs_od [file]`

ARGUMENTS

`file` Path of file to dump to terminal output.

OUTPUT

File contents, in hexadecimal form.

REQUIRED CONFIGURATION

Available only if `FS_SHELL_CFG_OD_EN` is `DEF_ENABLED`.

NOTES/WARNINGS

None.

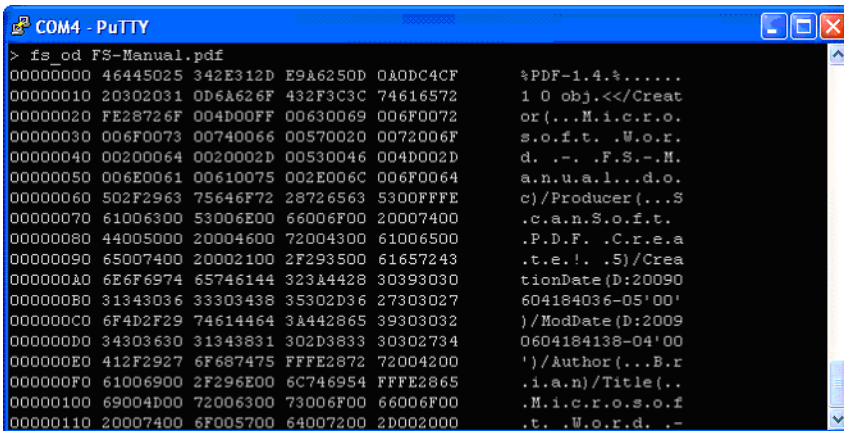

Figure F-7 fs_od output

F-3-12 fs_pwd

Write to terminal output pathname of current working directory.

USAGES

`fs_pwd`

ARGUMENTS

None.

OUTPUT

Pathname of current working directory..

REQUIRED CONFIGURATION

Available only if `FS_SHELL_CFG_PWD_EN` is `DEF_ENABLED`.

NOTES/WARNINGS

None.

F-3-13 fs_rm

Remove a file.

USAGES

```
fs_rm [file]
```

ARGUMENTS

file File path.

OUTPUT

None.

REQUIRED CONFIGURATION

Available only if `FS_SHELL_CFG_RM_EN` is `DEF_ENABLED` and `FS_CFG_RD_ONLY_EN` is `DEF_DISABLED`.

NOTES/WARNINGS

None.

F-3-14 fs_rmdir

Remove a directory.

USAGES

```
fs_rmdir [dir]
```

ARGUMENTS

`dir` Directory path.

OUTPUT

None.

REQUIRED CONFIGURATION

Available only if `FS_SHELL_CFG_RMDIR_EN` is `DEF_ENABLED` and `FS_CFG_RD_ONLY_EN` is `DEF_DISABLED`.

NOTES/WARNINGS

None.

F-3-15 fs_touch

Change file modification time.

USAGES

```
fs_touch [file]
```

ARGUMENTS

file File path.

OUTPUT

None.

REQUIRED CONFIGURATION

Available only if `FS_SHELL_CFG_TOUCH_EN` is `DEF_ENABLED` and `FS_CFG_RD_ONLY_EN` is `DEF_DISABLED`.

NOTES/WARNINGS

The file modification time is set to the current time.

F-3-16 fs_umount

Unmount volume.

USAGES

`fs_umount [vol]`

ARGUMENTS

`vol` Volume to unmount.

OUTPUT

None.

REQUIRED CONFIGURATION

Available only if `FS_SHELL_CFG_UMOUNT_EN` is `DEF_ENABLED`.

NOTES/WARNINGS

None.

F-3-17 fs_wc

Determine the number of newlines, words and bytes in a file.

USAGES

```
fs_wc [file]
```

ARGUMENTS

file Path of file to examine.

OUTPUT

Number of newlines, words and bytes; equivalent to:

```
printf("%d %d %d %s", newline_cnt, word_cnt, byte_cnt, file);
```

REQUIRED CONFIGURATION

Available only if `FS_SHELL_CFG_WC_EN` is `DEF_ENABLED`.

NOTES/WARNINGS

None.

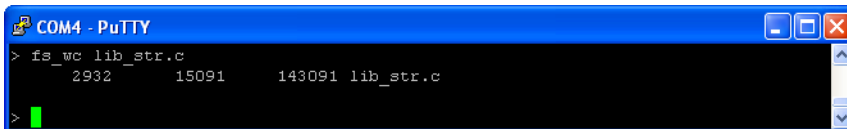

Figure F-8 `fs_wc` output

F-4 CONFIGURATION

Configuration constants can be used to enable/disable features within the μ C/FS shell commands.

FS_SHELL_CFG_BUF_LEN

FS_FAT_CFG_BUF_LEN defines the length of the buffer, in octets, used to read/write from files during file access operations. Since this buffer is placed on the task stack, the task stack must be sized appropriately.

FS_SHELL_CFG_CMD_####_EN

Each **FS_FAT_CFG_CMD_####_EN** separately enables/disables a particular **fs_####** command:

FS_FAT_CFG_CMD_CAT_EN	Enable/disable fs_cat .
FS_FAT_CFG_CMD_CD_EN	Enable/disable fs_cd .
FS_FAT_CFG_CMD_CP_EN	Enable/disable fs_cp .
FS_FAT_CFG_CMD_DF_EN	Enable/disable fs_df .
FS_FAT_CFG_CMD_DATE_EN	Enable/disable fs_date .
FS_FAT_CFG_CMD_LS_EN	Enable/disable fs_ls .
FS_FAT_CFG_CMD_MKDIR_EN	Enable/disable fs_mkdir .
FS_FAT_CFG_CMD_MKFS_EN	Enable/disable fs_mkfs .
FS_FAT_CFG_CMD_MOUNT_EN	Enable/disable fs_mount .
FS_FAT_CFG_CMD_MV_EN	Enable/disable fs_mv .
FS_FAT_CFG_CMD_OD_EN	Enable/disable fs_od .
FS_FAT_CFG_CMD_PWD_EN	Enable/disable fs_pwd .

FS_FAT_CFG_CMD_RM_EN	Enable/disable <code>fs_rm</code> .
FS_FAT_CFG_CMD_RMDIR_EN	Enable/disable <code>fs_rmdir</code> .
FS_FAT_CFG_CMD_TOUCH_EN	Enable/disable <code>fs_touch</code> .
FS_FAT_CFG_CMD_UMOUNT_EN	Enable/disable <code>fs_umount</code> .
FS_FAT_CFG_CMD_WC_EN	Enable/disable <code>fs_wc</code> .

Appendix

G

Bibliography

Labrosse, Jean J. 2009, *μC/OS-III, The Real-Time Kernel*, Micrium Press, 2009, ISBN 978-0-98223375-3-0.

Légaré, Christian 2010, *μC/TCP-IP, The Embedded Protocol Stack*, Micrium Press, 2010, ISBN 978-0-98223375-0-9.

POSIX:2008 The Open Group Base Specifications Issue 7, IEEE Standard 1003.1-2008.

Programming Languages -- C, ISO/IEC 9899:1999.

The Motor Industry Software Reliability Association, *MISRA-C:2004*, Guidelines for the Use of the C Language in Critical Systems, October 2004. www.misra-c.com.

<http://www.clusterbuilder.org/>

Cho, H., Shin, D., Eom, Y. I. 2009, *KAST: K-Associative Sector Translation for NAND Flash Memory in Real-Time Systems*, Architecture, 507-512. IEEE.

H

µC/FS Licensing Policy

H-1 µC/FS LICENSING

H-1-1 µC/FS SOURCE CODE

This book contains µC/FS precompiled in linkable object form, an evaluation board and tools (compiler/assembler/linker/debugger). Use µC/FS for free, as long as it is only used with the evaluation board that accompanies this book. You will need to purchase a license when using this code in a commercial product, where the intent is to make a profit. Users do not pay anything beyond the price of the book, evaluation board and tools, as long as they are used for educational purposes.

You will need to license µC/FS if you intend to use µC/FS in a commercial product where you intend to make a profit. You need to purchase this license when you make the decision to use µC/FS in a design, not when you are ready to go to production.

If you are unsure about whether you need to obtain a license for your application, please contact Micrium and discuss your use with a sales representative.

CONTACT MICRIUM

Micrium
1290 Weston Road, Suite 306
Weston, FL 33326

+1 954 217 2036
+1 954 217 2037 (FAX)

E-Mail: sales@Micrium.com
Website: www.Micrium.com

H-1-2 µC/FS MAINTENANCE RENEWAL

Licensing µC/FS provides one year of limited technical support and maintenance and source code updates. Renew the maintenance agreement for continued support and source code updates. Contact sales@Micrium.com for additional information.

H-1-3 µC/FS SOURCE CODE UPDATES

If you are under maintenance, you will be automatically emailed when source code updates become available. You can then download your available updates from the Micrium FTP server. If you are no longer under maintenance, or forget your Micrium FTP username or password, please contact sales@Micrium.com.

H-1-4 µC/FS SUPPORT

Support is available for licensed customers. Please visit the customer support section in www.Micrium.com. If you are not a current user, please register to create your account. A web form will be offered to you to submit your support question,

Licensed customers can also use the following contact:

CONTACT MICRIUM

Micrium
1290 Weston Road, Suite 306
Weston, FL 33326

+1 954 217 2036
+1 954 217 2037 (FAX)