

- 1 HOUSING MATERIAL: LIQUID CRYSTAL POLYMER PER ASTM D5138 LCP000 G30A 32250.
- 2 CONTACT MATERIAL: PHOSPHOR BRONZE PER UNS ALLOY NO. C51100, TEMPER: H04.
- 3 CONTACT FINISH:
 UNDERPLATE (ENTIRE CONTACT):
 0.00127 MIN NICKEL PER SAE-AMS-QQ-N-290
 ON MATING SURFACES:
 FLASH GOLD PER ASTM B 488, OVER
 0.00076 MIN PALLADIUM-NICKEL OVER UNDERPLATE, OR
 0.00076 MIN GOLD PER ASTM B 488 OVER UNDERPLATE.
 ON LEADS:
 0.00381 MIN TIN-LEAD OVER UNDERPLATE.
 LUBRICATION (MIN MATING SURFACES)
 SURFACE CONDITIONER AFTER PLATING.
- 4 PART MARKING PER AMP SPEC 115-9009.
 LOCATED APPROXIMATELY AS SHOWN.

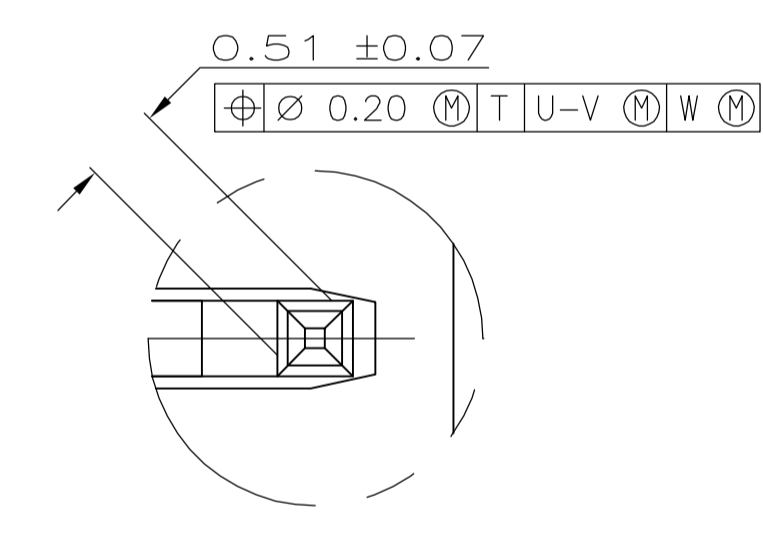

DETAIL Z
 SCALE 20:1

RECOMMENDED CIRCUIT PATTERN
 PER IPC-D300 TYPE II, CLASS C
 (COMPONENT SIDE)

6.00	1	4.25	6.50	10.00	5	11.83	3	8	536600-1
G	F	E	D	C	B	A	FINISH	NO OF POSN	PART NUMBER
THIS DRAWING IS A CONTROLLED DOCUMENT.		DIN D.R.BENDER 08/11/92		CHK R.L.BENDORF 09/03/92		Tyco Electronics Corporation Harrisburg, PA 17105-3608			
DIMENSIONS: mm		TOLERANCES UNLESS OTHERWISE SPECIFIED:		PRODUCT SPEC		NAME Z-PACK 2mm FB, POWER MODULE, PIN ASSEMBLY			
0 PLC ± -		1 PLC ± -		2 PLC ± 0.13		APPLICATION SPEC		SIZE A1	
3 PLC ± -		4 PLC ± -		ANGLES ± -		MATERIAL		CAGE CODE 00779	
MATERIAL		FINISH		WEIGHT		DRAWING NO. 536600		RESTRICTED TO	
1 2		3		CUSTOMER DRAWING		SCALE 4:1		SHEET 1 OF 1	